

HUGO GEINSBACK, Editor

# RADIO CRAFT

AND POPULAR ELECTRONICS



NEW ANTI-NOISE  
MICROPHONE  
SEE PAGE 202

JANUARY

1944

25¢

CANADA 30¢

RADIO-ELECTRONICS IN ALL ITS PHASES

# WESTON



## CONTINUING LEADERSHIP ... through the war and beyond!

The start of the new year finds instrument headquarters still *busy at it* in the final drive for victory. Dependable WESTON instruments, in all familiar types, continue flowing in unprecedented quantities to every battle front. *In new types, too*; for all during this period of stress WESTON development laboratories also have *led the way* ... continually meeting the new

measurement problems of this mechanized war. Thus when instrument priorities are relaxed, WESTONS will continue as industry's *standards* for all measurement needs. For, new measurement tools as well as *old* will be available in their most *trustworthy form* ... here at instrument headquarters. Weston Electrical Instrument Corp., 616 Frelinghuysen Ave., Newark 5, N. J.

Laboratory Standards ... Precision DC and AC Portables ... Instrument Transformers ... Sensitive Relays ... DC, AC, and Thermo Switchboard and Panel Instruments.

# WESTON

Specialized Test Equipment ... Light Measurement and Control Devices ... Exposure Meters... Aircraft Instruments... Electric Tachometers... Dial Thermometers.

**FOR OVER 55 YEARS LEADERS IN ELECTRICAL MEASURING INSTRUMENTS**



J. E. SMITH, President  
National Radio Institute  
(Our 30th Year)

# I WILL SEND A SAMPLE LESSON FREE to PROVE I can Train You at Home in Spare Time to BE A RADIO TECHNICIAN

## I Trained These Men



**\$200 A MONTH  
IN OWN  
BUSINESS**

"For several years I have been in business for myself making around \$200 a month. Business has steadily increased. I have N.R.I. to thank for my start in this field." **ARLIE J. FROEHNER**, 300 W. Texas Ave., Goose Creek, Texas.

**\$5 to \$10 Week in Spare Time**

"I am engaged in spare time Radio work. I average from \$5 to \$10 a week. I often wished that I had enrolled sooner. All this EXTRA money sure does come in handy." **THEO. DORE K. DuBREE**, Horsham, Pa.



**1st Lieutenant in Signal Corps**



"I cannot divulge any information as to my type of work but I can say that N.R.I. training is coming in mighty hands these days." **RICHARD W. ANDERSON** (address omitted for military reasons.)

**Extra Pay in  
Army, Navy, Too**



Men likely to go into military service, soldiers, sailors, Marines, should mail the Coupon

Now! Learning Radio helps Service men get extra rank, extra prestige, more interesting duties. **MUCH HIGHER PAY.** Also prepares for good Radio jobs after service ends. Over 1,700 Service men now enrolled.

**More Radio Technicians and Operators Now Make \$50 a Week Than Ever Before**

I will send you a sample Lesson, "Getting Acquainted with Receiver Servicing," to show you how practical it is to train for Radio at home in spare time. It's a valuable lesson. Study it—keep it—use it—without obligation! Tells how "Superhet" Circuits work, gives hints on Receiver Servicing, Locating Defects, Repair of Loudspeaker, I.F. Transformer, Gang Tuning Condenser, etc. 31 Illustrations. And with this Lesson I'll send my 64-page illustrated book, "Win Rich Rewards in Radio." It describes many fascinating jobs Radio offers, explains how N.R.I. trains you at home for good pay in Radio! Get both FREE by mailing coupon!

**Big Demand Now for Well-Trained Radio Technicians, Operators**

There's a big shortage today of capable Radio Technicians and Operators. Fixing radios pays better now than for years. With new Radios out of production, fixing old sets, which were formerly traded in, adds greatly to the normal number of servicing jobs.

Broadcasting Stations, Aviation and Police Radio, and other Radio branches are scrambling for Operators and Technicians. Radio Manufacturers, now working on Government orders for Radio equipment, employ trained men. The Government, too, needs hundreds of competent civilian and enlisted Radio men and women. You may never see a time again when it will be so easy to get started in this fascinating field.

**Many Beginners Soon Make \$5, \$10 a Week EXTRA in Spare Time**

The moment you enroll for my Course I start sending you EXTRA MONEY JOB SHEETS that show how to earn EXTRA money fixing Radios. Many make \$5, \$10 a week EXTRA in spare time while still learning. I send you SIX big kits of real Radio parts. You LEARN Radio fundamentals from my lessons—PRACTICE what you learn by building typical circuits like those illustrated on this page—PROVE what you learn by interesting tests on the circuits you build.

**Be Ready to Cash in on Good Pay Jobs Coming in Television, Electronics**

Think of the NEW jobs that Television, Frequency Modulation, Electronics, and other Radio developments will open after the war! You have a real opportunity. I will train you to be ready to cash in when Victory releases these amazing wartime Radio developments for peacetime uses! But the opportunity the war has given beginners to get started in the fascinating field of Radio may never be repeated. So take the first step at once. Get my FREE Lesson and 64-page, illustrated book. No obligation—no salesman will call. Just mail the coupon in an envelope or paste it on a penny postal. Get started today on the road to better pay! —J. E. SMITH, President, Dept. 4AX, National Radio Institute, Washington 9, D. C.

**TRAINING MEN  
FOR VITAL  
RADIO JOBS**

**GOOD FOR BOTH** 64 PAGE BOOK **FREE**  
SAMPLE LESSON

Mr. J. E. SMITH, President, Dept. 4AX  
NATIONAL RADIO INSTITUTE, Washington 9, D. C.

Mail me FREE, without obligation, your Sample Lesson and 64-page book, "Win Rich Rewards in Radio." (No Salesman will call. Please write plainly.)

Name ..... Age .....

Address .....

City ..... State ..... 4FR

## You Build These and Many Other Radio Circuits With Kits I Supply!

By the time you've conducted 60 sets of Experiments with Radio Parts I supply—have made hundreds of measurements and adjustments—you'll have had valuable PRACTICAL experience.



You build this SUPERHETERODYNE CIRCUIT containing a preselector, oscillator-mixer-first detector, i.f. stage, diode-detector-a.v.c. stage and audio stage. It will bring in local and distant stations. Get the thrill of learning at home evenings in spare time while you put the set through fascinating tests!

You Build this MEASURING INSTRUMENT yourself early in the Course, useful for Practical Radio work on neighborhood Radios to pick up EXTRA spare time money. It is a vacuum tube multimeter, measures A.C., D.C. and R.F. volts, D.C. currents, Resistance, Receiver Output.

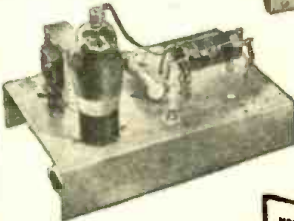
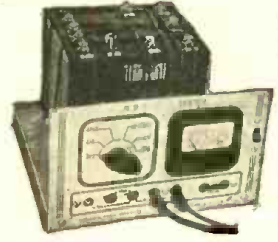

Building this A. M. SIGNAL GENERATOR will give you valuable experience. Provides amplitude-modulated signals for test and experimental purposes.





"RADIO'S GREATEST MAGAZINE"

HUGO GERNSBACK, *Editor-in-Chief*  
 FRED SHUNAMAN, *Associate Editor*  
 G. ALIQUO, *Circulation Manager*

**IN THE NEXT ISSUE**

- Electronic Gun Directors
- Ghirardi on Meter Errors
- More Systematic Servicing
- Principles of FM Receivers
- Fake Radio-Medical Device

Published by Radcraft Publications, Inc.  
 Publication office: 29 Worthington Street,  
 Springfield 3, Mass.  
 Editorial and Advertising Offices: 25 West  
 Broadway, New York City 7  
 Chicago Advertising Office: Radio-Craft, 520  
 North Michigan Avenue, Chicago 11, Ill.

RADIO-CRAFT is published monthly, on the  
 25th of the month preceding that of date; sub-  
 scription price is \$2.50 per year in U. S. (In  
 foreign countries, 75c additional per year to  
 cover postage; Canada, 50c additional.) En-  
 tered at the post office at Springfield as  
 second-class matter under the act of March 3,  
 1879. All communications about subscriptions  
 should be addressed to: Radio-Craft, 25 West  
 Broadway, New York 7, N. Y.

Notice of CHANGE OF ADDRESS should  
 reach us at least one month in advance. Be  
 sure to give your OLD ADDRESS as well as  
 the new as without the old address we cannot  
 find your name in our files.

**Foreign Agents**

- London—Atlas Publishing and Distributing  
 Co., Ltd., 18 Bride Lane, Fleet St., London,  
 E. C. 4.
- Melbourne—McGill's Agency, 179 Elizabeth  
 St., Australia.
- Dunedin—James Johnston, Ltd., New Zealand.

Text and illustrations of this magazine are  
 copyright and must not be reproduced without  
 permission of the copyright owners.  
 Copyright, 1944, Radcraft Publications, Inc.

Editorial: Shrinking Radio..... by Hugo Gernsback 199  
 The Radio Month in Review..... 200

**POPULAR ELECTRONICS**

Popular Electronics, Part XII..... by Raymond F. Yates 203  
 Sunspots and Radio..... by Henry E. Hallborg 205  
 Phototubes..... 210

**WARTIME RADIO**

Army Uses Anti-Noise Microphone (cover feature)..... 202

**SERVICING**

More Errors in Meters, Part III..... by Alfred A. Ghirardi 206  
 Servicing Notes..... 216  
 Systematic Circuit Tests..... by R. E. Altomare 217

**RADIO SERVICE DATA SHEET:**

No. 331: Meissner Radio-Phonograph Recorder..... 218  
 Oscillating Radios..... by Jack King 221

**RADIO TRAINING**

Oscillators—How They Work..... by Robert F. Scott 208  
 We Learn the Hard Way..... by James Langham 211  
 Transmitters for FM, Part III..... by Jules M. Kleinman 212

**TEST INSTRUMENTS**

A Versatile Tester..... 214

**EXPERIMENTERS**

Hughes Balance Metal Detectors..... by Eric Leslie 220

**DEPARTMENTS**

Servicing Notes (See Servicing)..... 216  
 RADIO SERVICE DATA SHEET (See Servicing)..... 218  
 Latest Radio Apparatus..... 222  
 The Listening Post..... 224  
 Question Box..... 226  
 The Radio Experimenter..... 228  
 Radio Kinks..... 230  
 The Mail Bag..... 255  
 Book Review..... 256



**ON THE COVER**

Our illustration shows the new anti-noise lip microphone now used by the Army. This is a "differential" microphone which cancels outside sound, no matter what its intensity. This microphone can even be used at the height of battle with machine guns and shells exploding nearby.



# FIRST...

*Hallicrafters has the honor of being the 1st exclusive radio manufacturer to receive the Army-Navy Production Award for the 3rd time!*



**BUY MORE BONDS!** **hallicrafters**  
The World's Largest Exclusive Manufacturer of Short Wave Radio Communications Equipment



# CASH PRIZE CONTEST!

## FOR RADIO MEN IN THE SERVICE! "WRITE A LETTER"

As you know, the Hallicrafters make a wide range of Radio Communications equipment, including the SCR-299 Mobile Communications unit. We are proud of our handiwork, proud of the job you men have been doing

with them on every battlefield.

### **RULES FOR THE CONTEST**

We want letters telling of actual experiences with this equipment. We will give \$100.00 for the best such letter received during each of the five months of No-

vember, December, January, February and March! (Deadline: Midnight, the last day of each month.)

We will send \$1.00 for every serious letter received so even if you should not win a big prize your time will not be in vain.

Your letter will be our property, of course, and we have the right to reproduce it in a Hallicrafters advertisement.

Good luck and write as many letters as you wish. V-Mail letters will do.

*W. J. Hallicrafters*



BUY MORE BONDS!

**the hallicrafters co.**  
CHICAGO, U.S.A.

2611 INDIANA AVENUE - CHICAGO, U.S.A.  
MAKERS OF THE FAMOUS SCR-299 COMMUNICATIONS TRUCK

RADIO-CRAFT for JANUARY, 1944

# HERE IS YOUR SUCCESS CHANCE

BE A

# RADIO-ELECTRONIC TECHNICIAN!

**SPRAYBERRY TRAINS YOU  
QUICKLY FOR WAR  
AND PEACETIME WORK**



**IF YOU REMAIN A  
CIVILIAN OR ENTER  
MILITARY SERVICE . . .  
Radio Training Will  
Enhance Your Future!  
• READ THESE LETTERS •**

**One Job Nets About \$26.00**  
"Since last week I fixed 7 radios, all good-paying jobs and right now I am working on an amplifier system. This job alone will net me about \$26.00. As long as my work keeps coming in this way, I have only one word to say and that is "Thanks to my Sprayberry training" and I am not afraid to boast about it."—ADRIEN BENJAMIN, North Grosvenordale, Conn.

**Sprayberry Graduate Wins  
Out in Army Test**

"Since I completed your elegant Course in Radio I have been drafted into the Army and put into the Signal Corps. I had to compete to get the job I now hold and as a result of my training with you, I made the best grade and got the job. The point I am driving at is if it hadn't been for your thorough course in Radio I would probably be peeling potatoes now. I recommend your training to all because it is written in language that the average layman can understand."—ARCH PLUMMER, JR., Fort Meade, Md.

**Student Makes \$15.00 to \$20.00  
A Week in Spare Time**

"After starting your Course I began doing minor radio service jobs and I want to say that I have been flooded with work. So much so that I have had to neglect my lessons. I want to say your training has done a great deal for me. I am making \$15.00 to \$20.00 a week in spare time. Even so, I'm going to go back to my studies and finish the Course."—SANFORD J. CHILCOINE, Whitley, Ontario, Canada.

**You Do Practice-Giving Experiments  
with Real Equipment**

The offer I make you here is the opportunity of a lifetime. It's your big chance to get ready for a wonderful future in the swiftly expanding field of Radio-Electronics INCLUDING Radio, Television, Frequency Modulation, and Industrial Electronics. Be wise! NOW is the time to start. No previous experience is necessary. The Sprayberry course is short, intensive, and interesting. It starts right at the beginning of Radio. You can't get lost. It gets the various subjects across in such a clear, simple way that you understand and remember.

**You Get a Dual-  
Purpose Radio Set**

I supply you with Radio Parts which you use to gain pre-experience in Repair work. These same Parts are used for testing and for Signal Tracing, etc. I make it easy for you to learn Radio Set Repair and Installation Work . . . by practical, proved, time tested methods. I teach you how to install and repair Electronic Equipment. Your success is my full responsibility.

**FULL RADIO SET**

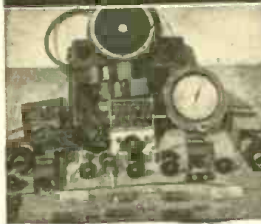

**Prepares You for a Business  
of Your Own . . . or  
Good Radio Jobs**

My training will give you the broad fundamental principles so necessary as a background no matter what branch of Radio you wish to specialize in. Soon you'll be qualified for a good paying job in one of the nation's Radio plants doing war work OR a business of your own. If you enter the Army, Navy, or Marines, my training will help you win higher rating and better pay. Let me prove what Sprayberry training can do for you.

**JUST OFF THE PRESS!**

**"How to Test and Repair Radio  
Sets Without Meters"**

Developed in the Sprayberry laboratory, this instructive volume tells about an amazingly simple, yet efficient method for Radio troubleshooting and repair without use of regular equipment made scarce due to war. Send for this free book now while the supply lasts and along with it, I will send you another big free book describing my Radio - Electronic training. Mail coupon.

**YOURS FREE  
THESE TWO  
VALUABLE BOOKS!**



**SPRAYBERRY ACADEMY OF RADIO**  
F. L. Sprayberry, Pres.

Box 500 TA,  
Pueblo, Colorado.  
Please rush my FREE copies of "HOW TO TEST AND REPAIR RADIO SETS WITHOUT METERS" and "HOW TO MAKE MONEY IN RADIO."

Name ..... Age .....

Address .....

City ..... State .....

Tear off this coupon, mail in envelope or paste on penny postcard.

**NOW! BECOME A MONEY-MAKING RADIO SPECIALIST**



## QUAKE-PROOF CONSTRUCTION



In a few cubic inches of space National Union tube designers plan and build their electronic skyscrapers. Many fragile parts of these intricate mechanisms are precisely balanced, buttressed and welded fast.

For N. U. engineers well know the *rough sailing* that's ahead for these tubes—the shocks, concussion, vibration—relatively far more shattering than the impact of an earthquake on a modern steel and masonry building. So their war job is to build tubes which will stand up and take what comes—whose parts will *stay* in precise alignment—whose exact

clearances will not be altered—whose air seal will not be broken.

To master this complicated construction problem calls for precision engineering of the first order—and a minute knowledge of the strength, rigidity and other characteristics of many metals. The point is—modern electronic tubes are scientific instruments. For post-war tubes of highest character, teamed-up with service assistance to match, service engineers can *count on* National Union.

NATIONAL UNION RADIO CORPORATION, NEWARK, N. J.  
Factories: Newark and Maplewood, N.J., Lansdale and Robeson, Pa.



# NATIONAL UNION

## RADIO AND ELECTRONIC TUBES

Transmitting, Cathode Ray, Receiving, Special Purpose Tubes • Condensers • Volume Controls • Photo Electric Cells • Panel Lamps • Flashlight Bulbs



# Shrinking Radio

.... As radio has expanded, its instrumentalities have never ceased shrinking—and the end is not in sight. ....

HUGO GERNSBACK

**R**ADIO is the one exception to the well-known term "bigger and better" as time goes on. Ever since radio first started from the days of wireless, down to the present, everything in connection with it has consistently shrunk. When Marconi first started trans-Atlantic wireless, the transmitting stations were gigantic in size. The towers alone, with their heavy cables, occupied several square blocks; while the transmitters were veritable thunder factories with large and cumbersome generators consuming thousands of horse power in energy. Little by little the multiple towers, as well as the transmitting power diminished and kept on shrinking, till today it is possible with a portable transmitter—that a man can carry on his back—to transmit radio intelligence to the Antipodes.

When the radio broadcast boom, in the early 20s, was in full swing, our radio receivers occupied the better part of a good-sized table top and the storage batteries that supplied the power often weighed several hundred pounds. It is a far cry from that to our present battery portables which weigh four or five pounds and which can receive, on a small loudspeaker, stations hundreds of miles away.

We started out in 1910 with a vacuum tube over four inches high, and already radio tubes have shrunk to the size of a flash light bulb; these tubes, incidentally, are being used in practically all the hearing-aid instruments today.

Radio aerials, which cluttered up every house roof in the country with a fearsome array of wires and poles, have also kept on shrinking since the early amateur days. Soon they will have disappeared entirely. Even the single wire aerial is rapidly going into the discard, and the "whip" automobile antenna will probably not survive many years in the post-war period. Nowadays the receiving aerial is built right into the set and is no

longer visible to the naked eye. This tendency will continue.

It is quite possible that there will be a short flare-up of the peculiar-looking aerials, which will sprout from our houses and apartments, when television gets under way. It seems that for some time to come, on account of the ultra-high frequencies on which television works, it will be necessary to use these special outdoor aerials. If they are not going to be on our roofs, they may be extending from our windows for a while. All this, however, will also be a transitory phenomenon, the same as the original aerial; in due time the television and F. M. aerials will be inside the sets.

In the receiving sets, shrinkage of the components has kept step with the diminishing size of the radio set and *vice versa*. Logically, the size of the set itself is wholly dependent upon the ultimate size of the components which constitute it. Tuning condensers, fixed condensers, transformers and radio tubes all have shrunk and will keep on shrinking in size. Even the loudspeakers had to keep in step. Recently we have seen the smallest loudspeaker yet; it measures only  $1\frac{3}{4}$  inches in diameter by 1 inch thick!

One might ask the question—if airplanes and locomotives constantly increase in size, why does radio, one of the most important examples of progress, keep on diminishing? The answer lies in the single word *utility*. Watches at one time were as big as an Idaho potato and heavier. Utility made watches shrink in size till today we have them smaller than a dime. Utility and necessity has forced radio constantly to grow smaller not only as to receiving sets but transmitters as well. The huge old transmitters required a terrific amount of space and the cost of erection was equally huge. Nowadays this is all changed and a powerful broadcast station transmitter is often housed in a fair-sized room. (Continued on page 239)

## Radio Thirty-Five Years Ago

In Gernsback Publications

**F**ROM the January, 1909, issue of MODERN ELECTRICS:

Announcing the *Wireless Association of America*. (This was the first and original wireless or radio association in the world.) The Board of Directors were: Dr. Lee deForest, President; John S. Stone, Vice-President; Wm. Maver, Jr., Secretary; Hugo Gernsback, Chairman.

Other articles of interest in the same issue:

A Telescopic Detector.  
A Carborundum Detector, by S. W. Newsom.  
Wireless Troubles (Testing and Operation of Transmitting Instruments), by L. Spangenberg.  
Novel Detector.

Wireless Hints, by Percy E. Palmer.  
Acrophone (radio phone) Tests Before British Admiralty, by Dr. Lee deForest.  
Modern Wireless Instruments (illustrations and description of the following deForest components: Variometer, Triple Variometer, Syntonizer [a loose coupler with two audios], also an Aerial switch).

### HUGO GERNSBACK Founder

Modern Electrics	1908
Electrical Experimenter	1913
Radio News	1919
Science & Invention	1920
Radio-Craft	1929
Short-Wave Craft	1930
Wireless Association of America	1908

Under the title, "A Walking Wireless Station," no doubt the first portable radio in the world, was also described in this issue. This first of the "Walkie-Talkies" was constructed by Hugo Gernsback and was used to advertise a transmitter and receiver which actually worked. One of the illustrations with the article shows the one-inch spark coil with spark balls, a small 4-wire aerial and an American flag—all carried on the shoulders of the operator, who also carried a box of batteries which operated the portable station. The other picture shows the perambulating transmitter on the downtown sidewalks of New York—the crashing sparks attracting crowds, which usually had to be dispersed by policemen.

# RADIO MONTH

## News Events of Interest

**P**REDICTION of the month is by David Sarnoff, President of the Radio Corporation of America. Turning from common post-war concepts of giant continental and world-wide hookups, he focuses his gaze on the relatively tiny:

"When this war ends, we shall be on the threshold of a new era in radio—an era in which man will see, as we'll hear, distant events. . . . The day may come when every person will have his own little radio station tucked away in his pocket, to hear and to communicate with his home or his office as he walks or rides along the street.

"We have much to learn about the microwaves, in which is wrapped up this new world of individualized radio. Tiny electron tubes may make it possible to design radio receivers and transmitters no larger than a fountain pen, a cigarette case, a billfold, or a lady's powder-box. Some day people may carry television screens on their wrists as they now carry watches. As the useful spectrum of radio approaches the frontiers of light, the apparatus will become simpler and more compact.

"Radio vision will have many uses. It will serve wherever sight is needed. For instance, it will be used to prevent collisions on highways and railroads, on seaplanes and on the airways of the world. Radio will be the new eye of transportation and commerce. Application of radio optics are unlimited."

Depicting science as a mighty ally of freedom, Mr. Sarnoff pointed out that scientific advances have brought much release from drudgery and from want. "However," he concluded, "we must progress still further. For better machines are not all that is needed to make a better life. We shall have a better world only to the extent that our social thinking and our social progress keep pace with the advance of physical science."

**H**UGE boom cranes that lift heavy sub-assemblies for a warship in one of the nation's shipyards are delicately balanced. The crane operator has to mind his "P's and Q's" or the weight may overturn the whole crane—cab 60 feet above ground, boom extending 100 feet or more, and all.

The crane stability gage, news of which was released by General Electric last month, eliminates such danger. It measures the tensile stress on one of the columns at the rear of the crane house. A strain gage element is connected in an electric bridge circuit in such a way that a minute change of

its air gap causes an unbalanced condition in a bridge circuit associated with it. The unbalance is indicated on the meter in a manner familiar to all radio testers, and shows the stress in the measured member. This can be interpreted in terms of equilibrium, and the gage gives the operator a continuous picture of his margin of safety, and automatically stops the crane if it takes on too heavy a load or if the boom moves too far out. In the illustration below, the dark part of the scale, which the pointer has just passed, indicates the danger point on the dial which keeps the operator posted on the stability of his crane at all times.

**T**ELEVISION available to 60 percent of the population of this country within 5 years of its post-war resumption, was seen by Thomas F. Joyce, of RCA's Television Department, speaking last month before a joint meeting of the American Television Society and the Advertising Club of New York.

The audience was, however, warned that television would not be ready to spring forward as an industry the day fighting ceases. It might take 2 or even 3 years before commercial sight-casting could get into its stride.

This widespread adoption of television will be possible, Mr. Joyce said, only if the radio industry can produce a television receiver at a ceiling price of \$200. Such a receiver, he believed, was possible, even when calculated on a basis of 1940 labor and material costs, and assuming no excise taxes would be levied. Lower costs of many items, such as cathode-ray tubes, would also be a factor.

**S**IMPLICITY in design as the keynote for electronic equipment aboard ships is urged by the Navy (Bureau of Ships) in a searching memorandum issued last month.

Noting the "astronomically large variety of components that must be carried in stocks throughout the world," the difficulties which confront servicing personnel, and related upkeep and maintenance problems, The Bureau points out that this is due in great part to a large variety of only slightly different components.

It is pointed out that electronics designers have for years been schooled in a doctrine of perfection, even to the point where special components may be constructed to secure a few per cent improvement in performance, and that in many cases such large reserve and safety margins have been provided that equipment and circuits not only meet all requirements but have a large margin of unuseable capacity.

An interesting set of self-examination questions have been provided for design engineers. The five questions, No. 1 of which deals with the question of "special components," follow:

- (a) Considering the overall performance desired, is this special component (transformer, condenser, etc.) actually necessary or will the component now in production be really satisfactory though slightly less efficient?
- (b) Considering the overall performance desired, and all of the resistors (or condensers) used, of approximately the same size, as a block, would it be undesirable or impracticable to use the same resistor value at all circuit points? Could that be a standard value?
- (c) Considering the overall performance desired, is it necessary to use so many different tube types? Or would it be desirable from a broad viewpoint to use fewer types perhaps even at the expense of an added stage?
- (d) Have the layouts, and wire plans become complicated because of a desire for ultimate performance (particularly gain) from each stage, so that excessive overall performance has been obtained at the expense of ease of maintenance?
- (e) On the other hand, are there components included that are marginal in design, that is: Do the transformers, condensers, etc., have a sufficient factor of safety against excessive current or voltage to insure trouble-free operation? Are tubes being worked beyond their ratings?

(Civilian as well as military servicemen would welcome such a step in the design of post-war radio apparatus for the home, and it is not too much to hope that such groups as the new Radio Technical Planning Board, the ASA and the RMA may take this matter under advisement.)

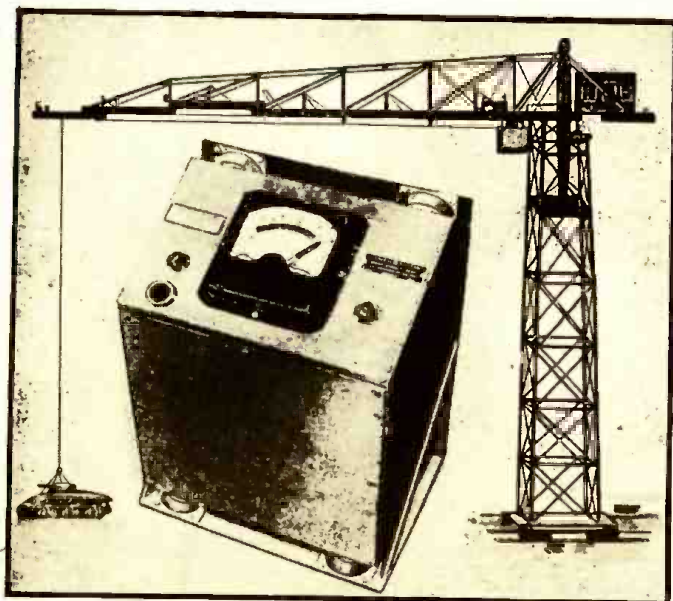

Cranes of this type are not easy to set up, once they have toppled from their tracks (and the attendant discomfort to the operator is likely to be great). The strain gage illustrated here prevents such accidents. By watching the pointer, the operator can keep his crane well within the limits of safety.

# IN REVIEW

## to the Radio Technician

**S**HORTAGES of batteries and tubes feared in large parts of the country, at the beginning of the year, have not been realized. The predictions that half the rural sets in the country would be out of action this winter, were not justified, though they seemed reasonably well-based when made.

A survey published last month by station WHO, Des Moines, Iowa, shows that 97.2% of the radios in that State are functioning. About 35% of the receivers of Iowa depend on batteries for their power, and while the survey was not classified as to battery and electric radios, it was found that in rural districts—many of which have electrification—94.7% of the sets were working, while in urban areas the percentage was 98.4.

Last winter's sturdy campaign for recognition of the battery shortage may well have been partly responsible for the supply of units to keep rural receivers operating. Iowa, with a number of neighboring States, put through the legislature resolutions urging Government authorities to take the situation into account in making allotments of supplies. It is significant, however, that only 44% of the battery users reported batteries in good condition. Weak batteries were reported by 30% of the users, and batteries whose owners were not sure of their condition, together with dead batteries, made up the balance.

**S**IGNALLERS of the American invasion army in Italy actually beat the infantry ashore at one point, according to last month's issue of "Army News." While communications men usually reach shore with the first wave, to establish immediate liason between shore and ship, this one was a little ahead of plan. The pioneering Signal Corps men took it in their stride, dug in at a good observation point, and phoned back information to the heavy guns of the landing squadron. The result was the destruction of a concentration of German Mark VI tanks, sweeping up to prevent the landing.

This one feat may well have meant the difference between success and failure, and without doubt saved hundreds of soldiers' lives. The gallant Signallers showed no disposition to rest on their laurels, and pressed ahead. When darkness settled on "D" Day and the division was fairly well established on shore, an inspection disclosed that contact had not only been maintained with the front line units, but also with those on each side of the division. When the first day ashore came to an end, the company found that it had established four switchboards over which was operating a net of telephones. In addition, it had installed six telegraph sets, laid one-half mile of field wire, and three miles of assault wire.

Future possibilities in the direction of wireless transmission of power can be seen in this globe of light, which is NOT the crystal ball to which such frequent reference has been made recently. Coated inside with phosphors of the type used in fluorescent lamps, it lights brilliantly when held in the path of a high-frequency electron beam. The "ball" is held by Mr. Samuel G. Hibben, director of applied lighting at the Westinghouse Lamp Division.



**F**ORECASTS of future wireless transmission of power, as well as several nearer and more practical applications of electronic lighting to post-war homes, were seen by spectators at a demonstration given by Samuel G. Hibben, director of applied lighting for the Westinghouse Lamp Division. The demonstration, which took place last month at the Waldorf-Astoria in New York City, showed laboratory models of new types of lamps, and of wartime and possible post-war uses of lamps and light.

Walking about the room carrying brilliant, vari-colored fluorescent tubes fully lighted although they were unconnected to sockets or electrical wiring, Mr. Hibben said:

"Although practical use of electric power transmitted without wires—except for signal purposes—is probably many years away, the spectacular strides in development of electron generating tubes we have made during World War II seem to be leading in that direction.

"Actually, these lamps are not connected with any power source. They are electronically harnessed to a beam of high frequency radio energy generated here in this room by a pre-war diathermy set such as your doctor might use to treat a cold.

"Generators vastly more powerful than this therapeutic apparatus are serving in wartime radio and communications equipment by transmitting radio waves in beams. This engineering advance, now applied wholly to fighting the war, conceivably may bring about the peacetime expansion of wireless power," the lighting expert continued, adding:

"Baby brothers of the fluorescent lamps now so widely used in war plants are illuminating bomber cockpits and airplane instrument panels. After the war, these six-inch long and other miniature fluorescents will have many safety and comfort applications. Because they use less current than an electric clock, they can be left burning night and day for such jobs as lighting clock faces and house numbers.

"These lamps can be made because we

have learned to handle glass tubing much better, aided by studies of glass which in itself possesses properties of fluorescence.

"Incidentally," Mr. Hibben concluded, "these phosphors are playing a significant part in protecting our fighting men. Fabrics impregnated with them line parachute cases so that a pilot downed at sea or in the jungle can be spotted by rescue craft; miles of phosphor-coated cloth tape provide luminous markings on invasion beaches, phosphor-coated controls glow on submarines and luminous signs made visible by phosphors mark escape hatches of merchant ships."

## INVENTORS!

### UNCLE SAM WANTS YOUR IDEAS

**YOUR** Government wants your ideas and inventions which will help win the war. Smaller War Plants Corporation, through the Technical Development Section at 226 West Jackson Blvd., Chicago, is set up to handle these new inventions and ideas. Already they have handled hundreds of new developments and devices and many have already gone to the "front" in the services of our armed forces. Many others have stayed on the home front to help boost civilian morale.

One simple invention might shorten the war by months. Another might save thousands of lives!

If any reader of *Radio-Craft* has an invention or idea that will help your Government, we urge you to contact immediately:

SMALLER WAR PLANTS CORPORATION,  
Technical Development Section,  
226 West Jackson Boulevard,  
Chicago 6, Illinois



Right: How the microphone looks when disassembled.



Signal Corps Photos

## Army Uses

# Anti-Noise Microphone

(Cover Feature)

**A** MICROPHONE for use amidst the thunder of modern battle—one that can be worn inside a tank, and which will transmit the words spoken into it without being affected by the roar of the motors and guns a few feet away—such is the Army's new lip microphone, illustrated on our front cover.

As may be seen from the cover picture, the instrument is useful not only in bringing the voice of the speaker more clearly to the distant listener, as in the case of battle-front radio. It may also serve to make instructions understandable over short distances in places where noise would drown out shouted intelligence, or interfere to an extent that would create a danger of misunderstanding words. The observer in the picture is connected by a straight wire line to the machine-gun crew a few feet away. The walkie-talkie on his back furnishes the necessary amplification. Information can thus be exchanged with greater speed and less danger of misunderstanding than by any other method. The din of battle, which would otherwise necessitate shouting, with many repetitions—or even a limited vocabulary of hand signals—has no effect. The saving of a few seconds in reporting an observation may well mean the difference between success and defeat, between life and death.

The reason for this microphone's uncanny ability to distinguish between wanted and unwanted sound is in its construction. It is so built that sound from a distance enters from both front and back with approximately equal volume. The two sounds then cancel out. Sounds originating an inch or so from one side of the diaphragm are felt with greater strength at one of the microphone openings than at the other. Thus the speaker's voice activates the microphone and currents are set up which carry the speech to amplifier or transmitter.

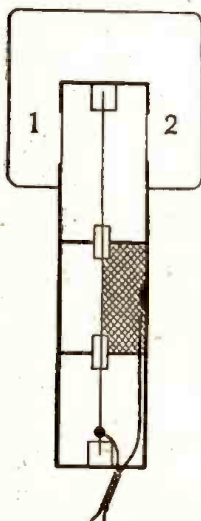

Fig. 1—The new differential microphone, showing how the cancellation of outside sound is affected.

Not only is the volume greater for sounds originating near one of the openings in the case of this unit; the difference in phase between the sounds entering one and the other opening is different. The voice has to travel more than twice as far to reach the one opening than the other. Thus the vibrations are out of phase on the two sides of the diaphragm, and fail to cancel. Sounds arriving from a distance which is great in comparison with the separation of the two openings of the microphone enter both sides practically in phase, with the result that an

almost complete cancellation takes place.

As will be seen from the figure, the microphone is reminiscent of the old carbon mike (which in fact it is) beloved by experimenters in the past. The two openings 1 and 2 are those through which the sounds enter, the unwanted ones at practically equal volume and phase, those originating near one of the openings with different volumes and phase relations.

The problem of constructing a noise-cancelling microphone is not quite as simple as just stated. Some attempts had been made to build up a "differential" microphone in the past. The most successful of these is the famous "cardioid" type. This is a combination of two microphones, one of which accepts sounds well from front and rear (bi-directional) and the other one of which accepts sound equally well from all directions. The output of these two microphones is mixed in such a way that the output of the omni-directional section reinforces that of the bi-directional unit for sounds in front of the microphone, and opposes it for sounds behind. This type of microphone picks sounds up from a roughly heart-shaped area.

Such a microphone is excellent for studio and stage use. Action on the field of battle calls for a highly compact and sturdy unit, and such a combination of two microphones can hardly be used. Some experimenting had been done on a microphone which would do its differentiating in the input instead of the output, but without success. The chief trouble was that resonances due to the construction of the unit itself actually increased instead of decreasing interfering sounds coming in at certain frequencies and at certain angles.

Tanks offer the greatest field for the new mike, because the noise inside them is so great as to make intercommunication with ordinary microphones very difficult. They are useful in other jobs.



Courtesy Electro-Voice Microphones

The inventor of the Army's new unit, F. Cheyney Beekley of the American Radio Relay League, is an amateur of long standing. Like many of the brotherhood, he had great confidence in the old carbon mike, and set about to get rid of the unwanted responses by correctly designing and proportioning the chamber enclosing the diaphragm. Thus what looks in the diagram like a meaningless series of enclosures, apparently of no value in collecting the sound or impressing it on the diaphragm, constitutes in reality the secret of success of this instrument. The design was worked up into its final form by Electro-Voice Mfg. Co., who are now making the unit for the Army.

To further adapt it to military use under conditions which would destroy an ordinary mike in short order, this unit is fully enclosed. Two thin shields, which can be seen over the openings 1 and 2, protect the interior from dust and dampness. The microphone may even be submerged in salt water for short periods of time, without damage. The outside "hood" seen over the sound openings is not for the purpose of protection against the elements, but is a "breath shield" to reduce the response to sudden puffs of breath.

Not the least of the advantages of the new unit is the fact that it is "worn" instead of being carried in the hand like the mike of the old walkie-talkie. With one of the new communications transmitter-receivers on his back, the differential mike firmly strapped to his upper lip, and the Army's ultra-small headphones in his ears under the helmet (see the September issue of *Radio-Craft*, Page 720) a soldier of the Signal Corps can keep in touch with his base station while wriggling along in thick jungle, making observations or doing other work which requires the use of both hands, or even, in emergency, while manning a gun or taking part in an attack.

# POPULAR ELECTRONICS\*

By RAYMOND F. YATES

## PART 12—THE OPERATION OF CONDENSERS

UP to the present time, we have been treating the subject of electronics in a very broad sense and in its more glamorous phases. We are now ready to become a bit more specific and to narrow our discussion down in an effort to round off and polish up the broader concepts held by the student. The first thing that we shall deal with is the electrostatic storage of electrical energy and the electrostatic field. Without such things, there would be no electronics.

When we speak of the storage of electric energy, we do not speak of it in the sense of the so-called storage battery. This fact is mentioned to prevent confusion. It is spoken of in the sense of storing energy in a device known as a condenser.

Most students of electronics know something about magnetic fields, those invisible "lines of force" that extend outward not only from magnets but also from all conductors carrying electrons or electric current. Wherever a magnetic field exists which is caused by moving electrons, we also have an electrostatic field. This may be represented diagrammatically as in Fig. 1. Such electrostatic fields may co-exist with electromagnetic fields, always being at right angles to such fields.

In the second Part of this series, we demonstrated how electrostatic charges could be generated by disturbing or exciting electrons on non-conducting surfaces like glass, rubber, etc. When bodies were charged negatively they had a preponderance of electrons and when they were charged positively they had a deficiency of electrons. Indeed, in conductors of electricity, electrostatic fields or lines of force exist wherever there is a difference of electrical potential. Even coils of wire carrying current have small electrostatic fields between their turns, and a coil of wire, like a condenser, has a certain electrostatic capacity to store energy. So important is this matter that the student cannot hope to get very far in the subject of electronics without a good understanding of electrostatics.

Any two conductors separated by a non-conductor form a condenser or capacitance and have the power to store and to discharge electricity. The material separating the two conductors is the dielectric. It may be glass, mica, air, etc. and the better a non-conductor it is, the better the resulting condenser will be. The capacity of condensers to store electricity electrostatically will not only depend upon the nature of the dielectric but also upon such factors as its thickness and its area and the area of the conductor elements or "plates" associated with it. The distance separating the plates of a condenser is also vital.

The earliest condenser was the Leyden jar invented by Musschenbroek in Leyden, Holland, during the year 1746. When such "jars" were connected to an electric influence machine, they were found to be able to "store" electricity. The device is shown in Fig. 2 where it can be seen that such jars are made by placing tinfoil or any conducting material on both the inside and the outside.

When such jars or condensers were connected to the early electrostatic influence machines, they became charged and they could be quickly discharged in the manner shown in Fig. 2. When the discharging device, which did nothing more or less than bring the outside conducting surface of the jar nearer, electrically speaking, to the

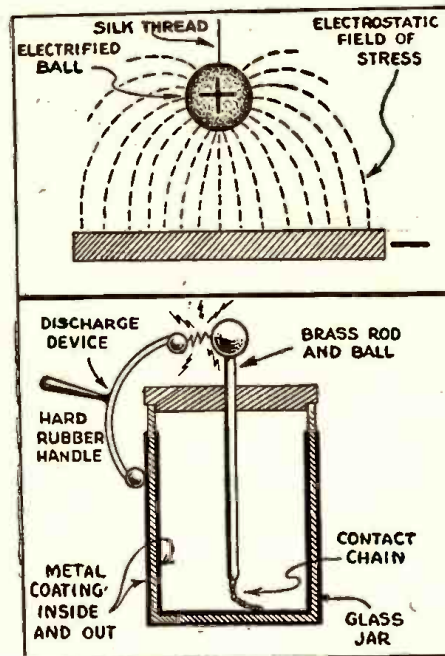

Fig. 1.—Electrostatic field around a charged body. Fig. 2.—A Leyden jar, the first known type of electrical storage devices, or condenser.

inside conducting surface, was touched to the outer layer and the other end brought near the knob connected to the inner layer, a point would eventually be reached where the voltage of the stored charge was sufficient to break down the air gap. At this instant, a loud, sharp discharge took place. In short, the jar was quickly "emptied."

Reference is made to Fig. 3 where we see a simple circuit involving a source of fairly high voltage, a key or switch, a condenser, a coil (inductance) and a resistance. When the key is depressed and electrons are permitted to flow from the bat-

tery to the condenser, the condenser will become charged; that is, electrons will pile up or accumulate on one of the condenser plates (or one set of the plates if a multi-plate device is employed). Immediately the key or switch is opened and the charging current is separated from the condenser, it proceeds to discharge its accumulated current through the resistance and through the coil or inductance.

Before this happens, a difference of electric potential exists between the plates of the condenser. So long as the condenser cannot relieve itself of its charge a state of electrostatic stress exists between the plates of the device. A purely mechanical analogy is the case of a steel spring placed under tension. Such springs have a certain amount of kinetic energy stored in them which may be released, or discharged. See Fig. 4. So it is with charged condensers, only the stored energy is electrical rather than kinetic.

Really, condensers depend upon the basic fact that like charges of electricity repel each other and unlike (such as + and -) attract each other. Negative charges (electrons) on one plate of a condenser (or one set of plates) will repel electrons on the opposite plate or plates and thereby set up an opposite or positive charge. Under such conditions the electrons have a great tendency to rush to the positive side of the condenser but are prevented from doing so by the dielectric.

We can see, then, that when the opposing sides of the condenser are connected electrically, electrons from the overburdened negative side will rush to the opposite side and there quickly overpower the positive charge. We quickly see, too, that this rush of electrons from the once-negative plate might be a bit overdone, so much so indeed, that this plate is left with a positive charge while the opposing plate becomes negative. In short, the conditions are reversed and they continue to reverse at a very rapid rate.

This causes our condenser to discharge an alternating current even though it was first charged with a direct current. It functions as a sort of electrical converter and the amount of current it discharges will depend upon the amount put in and upon the size of the condenser or its capacity, which is measured in farads or micro-farads. The micro-farad is used because the farad is

(Continued on following page)

Fig. 3.—What happens when a condenser discharges. Electrical momentum causes the current to surge back and forth a number of times. Inductance and capacity in the circuit increase this tendency greatly.

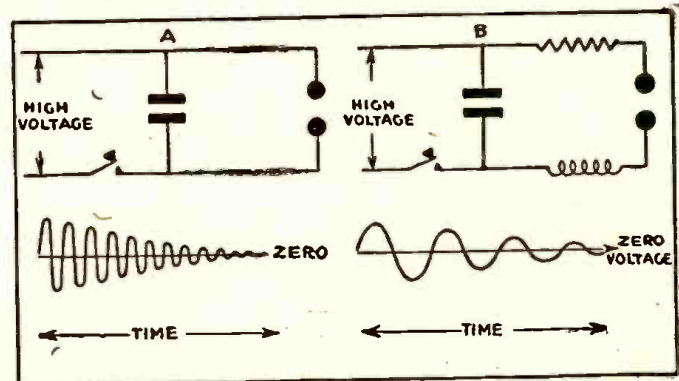

\*Application for Trade Mark Title pending in U. S. Patent Office.

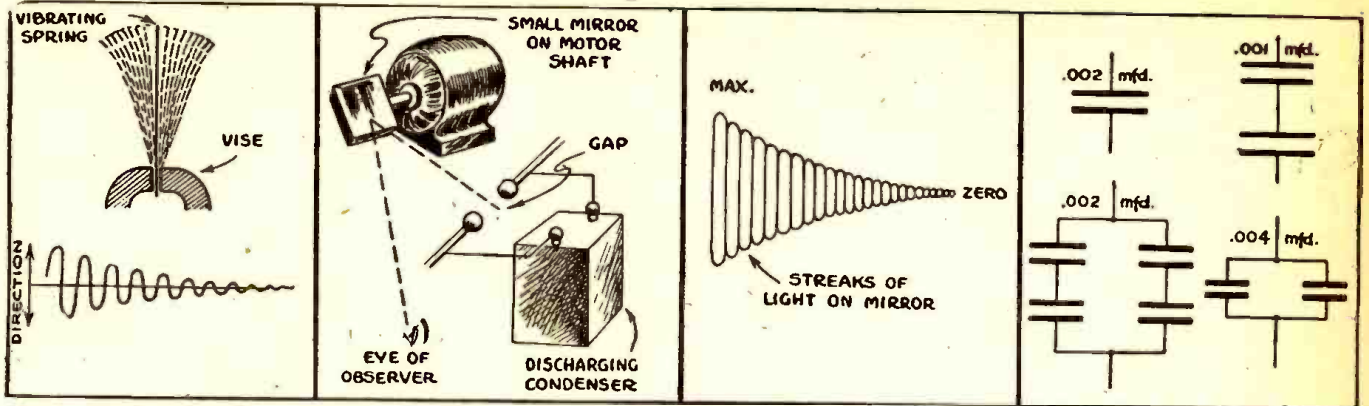

Fig. 4.—Mechanical analogy of the Fig. 3 action. Fig. 5.—How the oscillatory discharge is detected. Fig. 6.—The track of light in the rapidly rotating mirror. Fig. 7.—Different capacity combinations with .002 condensers, using series, parallel, and series-parallel connections.

far too large a unit for ordinary purposes and radio condensers.

Any experimenter in electronics can see for himself that such charges are oscillatory or alternating in nature by the very simple arrangement shown in Fig. 5 where a small revolving mirror is so arranged as to catch the image of a spark gap connected to a discharging condenser. When viewed, the mirror image appears as shown in Fig. 6. The graph of the discharge appears at the bottom of A, Fig. 3. Here it is seen to comprise a number of current reversals, each one becoming more feeble until a zero point is reached. It will be noticed here that the time line is only 1/1000th second long and that the alternating current produced has a very high-frequency of reversal. Of course, if a condenser of very small capacity were discharging, it would do so still more rapidly and in some cases, if tiny condensers were involved, the discharge would be so rapid as to be utterly invisible in a revolving mirror even if a large spark were produced. Of course, tiny condensers cannot store enough voltage to produce a phenomenon of this kind.

We see, then, that the size of a condenser controls the frequency of its discharging current. But that is not all. Let us return again to Fig. 3, where a condenser is shown with its charging source and a resistance and an inductance. It so happens that this resistance and this inductance coil exercise a definite control over the discharge from the condenser. No matter what their size (that is, the amount of resistance and the number of turns of wire and its size in the inductance) the tendency is to slow down the discharge from the condenser and to decrease the frequency of the resulting discharge current. In short these things have a choking effect on the electrons and they can not dash back and forth in the circuit with the alacrity they would display if neither the resistance nor the inductance were present. Indeed, if either the resistance

or the inductance or both become too great, the discharge from the condenser will be slowed down to such an extent that it will look more like a direct current and, if the resistance especially is high enough, several hours may be required for the discharge to be completed.

It will be seen from what has been said that the condenser really offers us a means whereby alternating currents may be generated and whereby the frequency of alternating currents may also be controlled. Perhaps now for the first time, the variable radio condenser begins to make sense. Here is a capacitance that may be adjusted so that it may be caused to hold charges of various amounts and discharge them at different intervals of time.

The only way in which a direct current may pass through a fixed or variable condenser is to flow until the condenser becomes fully charged. It will then discharge, providing the proper electrical conditions are set up. As we have learned, the electrical energy thereupon issues from the discharging condenser in the form of a rapidly diminishing electric current.

In Fig. 7 we see the different ways in which condensers may be connected when more than one is to be used. Perhaps we already know that the way in which things electrical are connected often means a great deal. For instance, when electrical cells are connected in series, we add their voltages while the current is the current of a single cell. When electrical resistances are connected in series, the total resistance becomes the sum of all resistances used in the series group.

When condensers are placed in parallel, we find that the resulting capacity is equal to the sum of all capacities.

On the other hand, when such condensers are hooked up in series, the total capacity of the group turns out to be really less than the capacity of one condenser, assuming that they were all of the same ca-

capacity before connections were established. In each of the drawings (Fig. 7) it is assumed that the condensers used have a capacity of .002 microfarads.

Condensers of all kinds are made not only to hold certain charges but they are also made to operate at certain voltages. Thus care must be exercised in their manufacture so that voltage breakdowns in insulation will not occur.

Fig. 8 shows how large capacities may be confined to very small spaces. Condensers for low voltages are also made with special grades of waxed paper separating the foil conductors from each other. Still other condensers are formed by placing anodic formations (oxides of aluminum electrolytically produced) upon pure aluminum foil. This forms the dielectric material.

If the experimentally inclined reader can lay hands on a small 15,000 volt neon sign transformer and a 15,000 mica condenser of .004 capacity, the action of condensers on high voltage discharges may be studied. When such transformers are connected to a small spark gap, a rather hot, silent discharge takes place. After the condenser is set in the transformer secondary circuit as shown in Fig. 9, the color, sound and length of the spark immediately change. The spark is now loud and blue because we are no longer watching the current direct from the transformer but rather we are seeing the discharge of the current from the condenser which the transformer current is now charging. It must be clear that such condensers are capable of charging and discharging at a very rapid rate, many thousands of times per second.

The number of home experiments with condensers will be limited due to the nature of the subject. The little gold leaf electroscope mentioned in the third Part of our series may be made and it will be available for the experiment. See Fig. 10.

Here an ordinary radio variable capacitor (Continued on page 241)

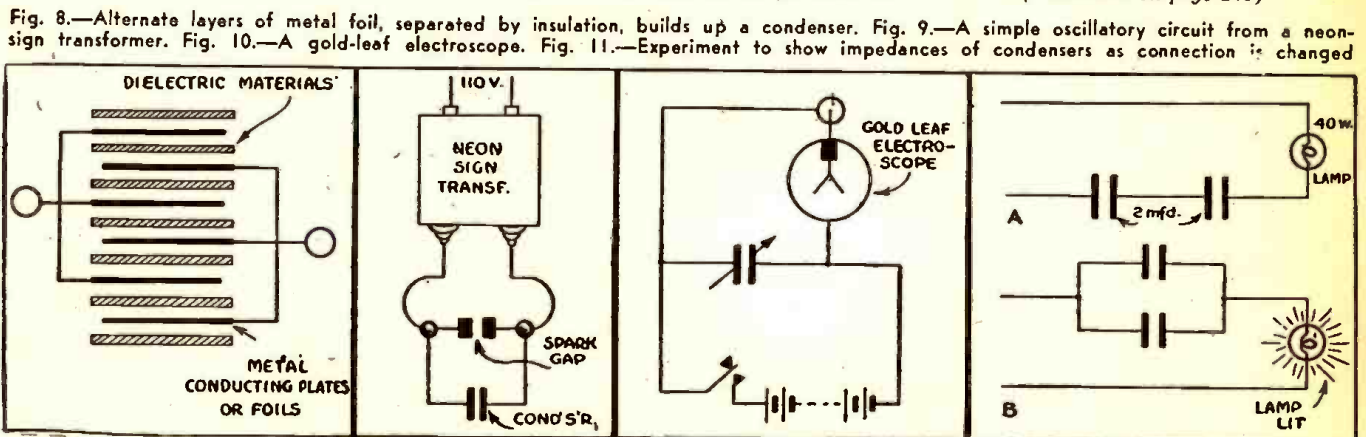

# Sunspots and Radio

By HENRY E. HALLBORG\*

THE passage of the center of the solar disc by a large sun spot group on March 1, 1941 was front page news all over the world. It was the occasion of an awe inspiring aurora, of complete interruptions of international cable and radio services, of the tripping of power circuit relays on Long Island, and of the melting of lead telephone cable sheaths at the Canadian border. This was an unusual sun spot barrage. Barrages continue to occur, however, in lesser degree, with more or less regularity; but without making front page news. A few of the observed interrelations between sun spot barrages and short wave radio disturbances will be recorded in this article.

Before examining sun spots, and their radio circuit effects, it may be profitable to consider first the earth, and its encircling envelopes. If one could be physically transported upward for a distance of several hundred miles, a number of distinct and individually characterized layers would be crossed. The first, and lowest of these, the "Troposphere"; extends upward to a height of about ten miles. This is the layer of earth-bound weather. In it, winds, clouds, and thunderstorms exist, continuously generating, in some part of the globe, radio static. The temperature would be observed to drop, as we ascended, about 17° F. per mile. The barometer would show a density at three miles only half that at the earth's surface.

A second envelope, the "Stratosphere", would be found, extending to a height of about twenty-two miles. The barometer here would register a pressure less than one-tenth that at the earth's surface, and the

\*R.C.A. Laboratories, New York City.

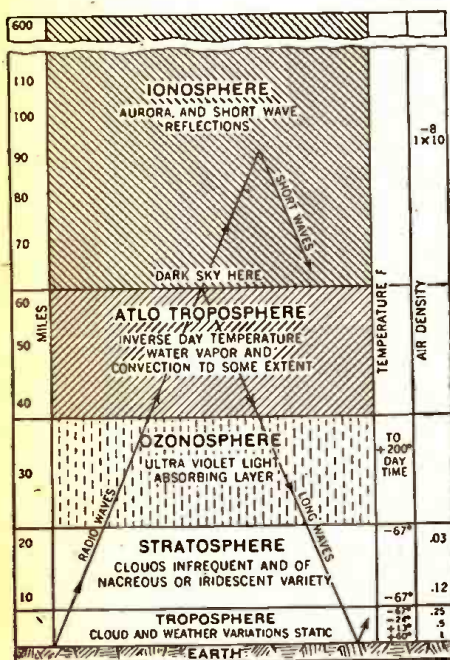

Fig. 1.—Chart of the earth's atmospheric layers. The radioist is chiefly interested in the highest one, the ionosphere, home of radio reflections.

The effects of the sun on radio reception have long been known. RCA research workers have uncovered data on the relation between sunspots and radio reception that will interest all short-wave radio receiver owners.

thermometer would read -67° F. This envelope is also known as the isothermal layer, since its temperature tends to be constant. The stratosphere is of greater practical interest to the rapidly expanding air commerce of the future than to the radio man, but the stratosphere flyer must not forget his oxygen supply, nor his radio equipment.

A third envelope, the "Ozonosphere", would next be encountered, extending upward to a height of about forty miles. This is the region of free ozone. It has the important property of absorbing the deadly actinic rays of the sun. Without the ozonosphere our earth would be a dead planet. The temperature of this layer, in absorbing the actinic rays of the sun, undergoes a temperature rise to about 200° F. At night the temperature falls to that of the stratosphere, about -67° F.

A fourth layer, the "Alto-Troposphere" would be found to extend above the ozonosphere to a height of about sixty miles. This is a region of great radio interest since in it are generated radio absorption screens and blankets created by processes later to be described. It is also a sunlight absorbing layer, and therefore undergoes wide temperature changes between day and night. Its air density has dropped to such low values that breakdown of the air particles by solar impact may be likened to the blue glow that occurs in a leaky radio tube. The region is a dividing zone between long and short radio waves. Long waves are reflected by it. Short waves suffer various degrees of absorption.

The fifth and last layer encountered, the "Ionosphere," extends upward from sixty miles to an indefinite upper height. It is the region of free ions, and of two major stratifications of these ions. The lower stratification, at a height of about seventy-five miles, is the well-known Kennelly-Heaviside layer, or E layer. The upper stratification, at a mean height of about two hundred miles, is the F layer. The F layer undergoes wide changes in ion density, and height. It separates into two layers, F<sub>1</sub> and F<sub>2</sub>, during daylight. Its characteristics vary widely with solar radiation activity, and with the seasons. The ionosphere may be considered both as the "radio roof" and the "radio ceiling." It is the roof with respect to radiations from the sun, and the ceiling for radiation emanating from radio transmitters on the earth. A diagram of the earth's encircling envelopes is shown in Fig. 1.

## SOURCE OF THE BARRAGES

Leaving, for the moment, the medium through which our earth-bound short waves must be propagated, we shall consider



Fig. 2.—A typical source of sun spot barrages. The great sun spot of July 1905 photographed by Yerkes Observatory.

briefly the surface conditions on the sun, where our solar barrages are generated.

Sun spots have been observed and charted for centuries. About 1925, when the communications possibilities of short waves became generally recognized, sun spots emerged from the realm of astronomical curiosities, to practical communications hazards. R.C.A. Communications early recognized the possibility of their influence upon the maintenance of an efficient international short wave radio service. A systematic study of solar and communications inter-relationship was therefore inaugurated on its world wide radiotelegraph networks. This study, from a solar point of view, was indirect. It dealt not with the appearance of the solar disc; but rather with the terrestrial effects of that appearance in such

(Continued on page 242)

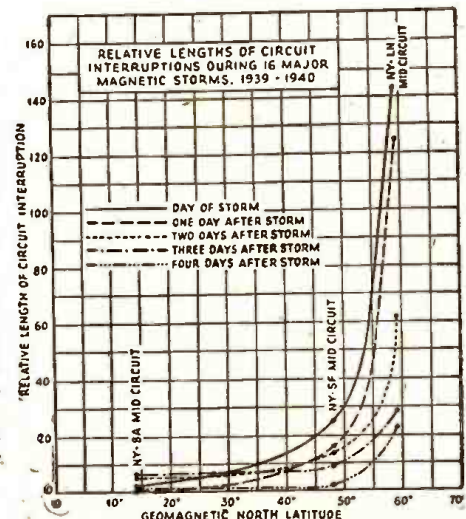

Fig. 3.—The relative length of circuit interruptions with respect to degrees from the north magnetic pole. Data obtained from sixteen major sun spot barrages during the years 1939 and 1940.

THUS far in our discussion we have considered only those inaccuracies that are *inherent* within every normally-functioning commercial indicating instrument. These inaccuracies are part of the instrument itself, and are inseparable from it.

In addition to these, measurements made with indicating instruments are subject to other inaccuracies involving the personal equation, over which the instrument maker has no control. No matter how high the inherent accuracy of the instrument, a certain amount of error is always introduced by the observer himself when he does not read the pointer position or indication correctly. When it stands between two divisions on the scale, good judgment is needed to estimate accurately the fraction involved. It happens frequently that due to careless reading of the pointer position the observational error may itself be almost as large as the inherent inaccuracy of the in-

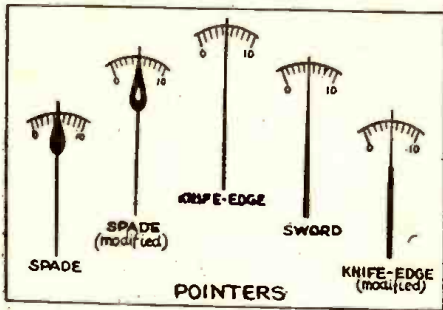

Fig. 1.—The old spade pointer did not make for accurate readings. Later models are much improved.

strument at that part of the scale—especially when the reading occurs on the lower portion of the scale where even a small observational error is a large percentage of the quantity being measured. A working knowledge of the various causes of these observational errors will suggest precautions for minimizing them in practice.

Reading or *observational* error is influenced by the size and shape of the pointer, the lighting conditions, the angle at which the pointer is read, the position of the pointer with respect to the extremities of the scale division, the steadiness of the quantity under measurement and, most greatly, by the care and skill of the observer. Errors of observation are apt to be *positive*, as well as *negative*.

Assume for the present, that both the quantity under measurement and the pointer are perfectly steady. The observational error possibilities for this condition will be separately analyzed.

#### EFFECT OF POINTER DESIGN

Test instrument manufacturers, by progressively improving pointer design, have made a great contribution to the reduction

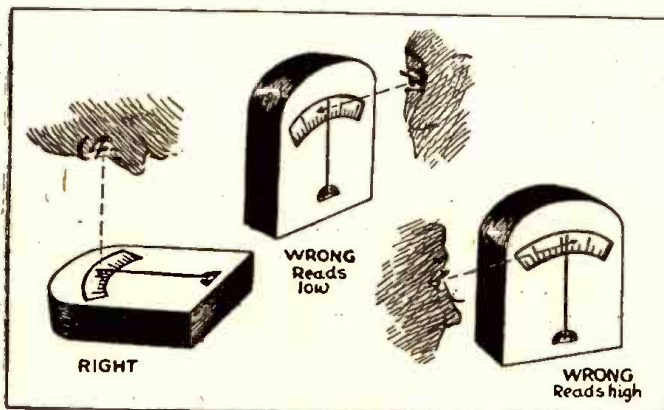

Fig. 2.—The line-of-sight is important in reading a radio meter. Errors are not likely to be as great as shown in the purposely exaggerated drawing here, but may be great enough to cause significant errors in readings, especially where small differences of pointer position make large differences in values.

# MORE ERRORS

of observational error, for the size and shape of the pointer have an important bearing upon how accurately its position will be read. The evolution of instrument pointer design is illustrated in Fig. 1.

The rugged but rather heavy *spade* pointer of earlier instruments, shown at (A), was designed to withstand easy bending when the indicating instrument was overloaded and the needle "slammed" or "pegged." Too, its large, black surface could be seen easily and its movement followed under poor lighting conditions. Its bluntness, however, defeated the accurate position reading now possible with the more popular thin pointers. The spade pointer is still used on many electrical measuring instruments whose inherent accuracy is not very high, on instruments which must be read under poor lighting conditions, on switchboard instruments which must be watched or read (not absolutely accurately) from a distance, etc. By cutting out the center of the spade pointer, as shown at (B), its mass may be decreased without materially decreasing its ruggedness. The spade pointer is satisfactory enough for many applications. It remains unsuitable for highly accurate readings.

At (C) is illustrated the true knife-edge pointer used to some extent on test instruments. Its knife-edge thinness permits very close readings, but it is more difficult to follow and read in bad light than is the spade pointer and, since less rugged, it is more easily bent when slammed or "pegged."

The tapered knife-edge or *sword* pointer shown at (D) represents one attempt to maintain the observational accuracy of the true knife-edge pointer, its tapered shape providing the desired ruggedness and visibility in poor light. It is used for some test instruments.

Another variation of the knife-edge pointer, adopted by many leading test instrument manufacturers, is shown at (E). Its rugged body, like the old spade pointer, gives good visibility even in poor light and is not easily bent when slammed against the stop during overload. The portion resting over the scale, however, is a flat, thin, knife-edge making possible accurate reading.

#### PARALLAX ERROR IN READING

Even though the instrument is provided

with a pointer designed for accurate reading, the observer himself may err in reading its position. The illustrations in Fig. 2 show how this can occur.

To read the pointer position, the observer—too often from any haphazard angle—closes one eye and squints through the other. This is wrong. Correctly, he should face the instrument squarely, his open eye *directly over* the pointer. His line of sight then goes through it, exactly at right-angles to the plane of the scale, as shown at (A) in Fig. 2.

If the head of the observer is at the *right* of the pointer, as shown at (B) the line of sight is *oblique*, and the pointer position is read *low*; if the head is at the *left* of the pointer, as shown at (C), the pointer position is read *high*. This observational error is said to be due to *parallax*. In order to take accurate instrument readings, therefore, always stand *directly over* the instrument and look *directly down* on the pointer, if the instrument is lying flat. If the instrument is vertical, stand *directly in front* of it, and look *directly at* the pointer. If the pointer happens to lie between two divisions on the scale, *estimate* its correct position as nearly as possible.

In precision indicating instruments, observational error due to parallax is reduced by providing a mirrored surface—usually cemented to the dial and located alongside of the scale markings—under the pointer as illustrated in Fig. 3. The image of the pointer appears in this mirror. To take a reading on such scales, the observer moves his head until the pointer is seen *directly over* its image in the mirror (the pointer hiding the image from view). He then knows that he is looking straight down onto the pointer, avoiding error due to parallax.

Aided by such a mirror, a skilled observer can read the scale position of a knife-edge pointer to within about 0.005-inch of its true value. Of course, the reading accuracy depends actually upon the steadiness of the pointer, upon the lighting conditions, the eyesight of the observer, and the care exercised.

Other measures taken by instrument manufacturers to reduce observational errors involve the use of indirect lighting on the instrument itself, anti-parallax scale and pointer, and non-glare glass. These are not ordinarily used on the test instruments employed in radio work, however, because they involve additional cost and are not really necessary in this work.

#### SCALE DISTRIBUTION EFFECTS

Most electrical indicating instruments employed in radio-electronic service work have uniformly-divided scales for both D.C. and A.C. current and voltage measurements. Most ohmmeter scales, on the other hand, are non-uniform. They are constricted at one end and are more open at the other.

For purposes of our discussion it is necessary to assume some average value by which the observed and actual position of the pointer might differ. A value of as much as 0.015 inch is common, even with a blade pointer and mirror to minimize parallax.



# IN METERS

## PART III

By ALFRED A. GHIRARDI

*Previous articles have discussed causes of error due to the meter itself. Now we are about to hear of errors caused by the Serviceman who reads it. Merely holding the meter at an angle or looking at it from the side may be a cause of large errors.*

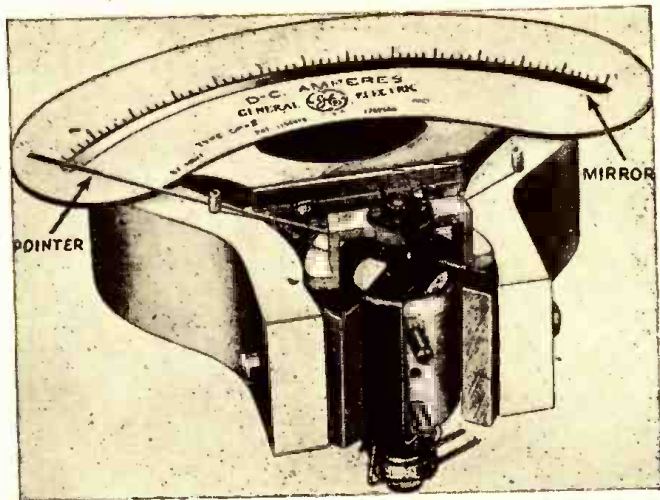

Courtesy General Electric Co.  
Fig. 3.—A precision-type meter, showing mirror under the pointer.

The resulting error in per cent of the indication is then dependent upon the scale distribution and the pointer deflection.

It is evident that for a uniformly-divided scale a given *observational* error causes a greater *percentage* error in the actual numerical quantity read if it occurs at the low end of the scale where the numerical quantities are small. This is another reason why it is advisable always to use a range that will cause the pointer to deflect beyond the first 1/5 of the scale.

Ohmmeter scales are non-uniform, and usually are reversed, i.e., the maximum values lie at the no-deflection end of the scale. Furthermore, the constricted portion of the scale also occurs at that end. For a scale of this type, a given observational error has the largest effect percentage-wise on the indication when the pointer deflection is very small, and again when it is almost full-scale value. Where the pointer deflection is very small the numerical values on the scale increase greatly for small increases of scale length, so a given observational error causes an appreciable percentage difference in the reading. Near the full-deflection end of the scale the divisions are much more open but because the numerical values are small a given observational error again causes an appreciable percentage difference in the reading. Observational errors are minimized by using an ohmmeter having a scale which is "open" in the region where most of the resistance readings normally taken during service work occur. Some commercial ohmmeters are purposely designed with this characteristic.

The length of the instrument scale also is an important factor in minimizing the effects of observational errors. By scale length is meant the linear length of the path described by the pointer in moving from one end of the scale to the other. Naturally, for a given numerical calibration range the longer is the scale in inches, the smaller the quantity (volts, Ma., ohms, etc.), each inch of scale length represents numerically, and consequently the smaller the percentage error in the indication caused by a given observational error in reading the pointer position. Naturally the permissible overall dimensions of the instrument places practical limits upon the length of scale that can be employed in any particular instrument design.

If the observed quantity varies in value while the instrument is being read it is well-nigh impossible to determine the pointer position accurately, and a fairly large observational error due to

this can occur. This will be discussed in greater detail later.

Inaccuracies can creep into instrument measurements simply because of the way the instrument is used, or the conditions under which the measurements are made. Certain errors present in one measurement may not occur again in the instrument under different measurement conditions—and vice versa. These inconstant errors include those due to *position influence, stray magnetic fields, electrostatic charges, external-temperature influence, frequency influence, wave form influence, alterable circuit conditions, fluctuation of quantity being measured, and use of wrong instrument range.*

Each of these will now be discussed in the order named.

### POSITION OF INSTRUMENT

In the construction of spring-controlled instruments an effort is made to have the moving element (consisting of the moving coil and frame, pivots, pointer, etc.) in a state of balance as regards gravitational effect—so that inclining the instrument in any direction from the normal operating position will not cause the pointer to be displaced. Portable indicating instruments are usually intended to be used with the axis of the movable coil in a vertical position—that is, with the pointer and scale in a horizontal position. Switchboard instruments are just the opposite.

If an instrument is perfectly balanced, it should read accurately no matter to what position it is tilted. To accomplish this, two small adjustable counterbalancing weights, (such as threaded lock or split nuts, or a wire helix that can be slid along) are placed on each end of a crosspiece (at right angles to the pointer), and one is placed on the tail end of the pointer, as illustrated in Fig. 4. Another method is to use a flexible "tail weight" which is bent until "balance" is obtained. Still another method is to use small drops of solder, shellac or lacquer, though this is not recommended because of subsequent changes in balance caused

by humidity and temperature changes. Good radio service equipment should employ indicating instruments that can perform in any position without introducing appreciable error.

Since exact balancing necessitates precise and tedious position adjustments of these weights, some indicating instruments leave their factory slightly unbalanced. Others may become so by jars and knocks received during shipment and subsequent use. As a consequence, errors (generally small) are likely to occur when such instruments are used in a tilted position other than that in which they were originally calibrated. Portable instruments are generally factory-calibrated when in a *horizontal position* (with the axis of the moving coil vertical).

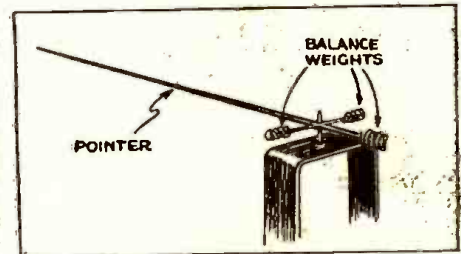

Fig. 4.—Proper adjustment of the balance weights permits operation of the meter in any position.

If an indicating instrument is designed to be used with its pointer and scale in a *horizontal* position, it should not be used in a *tilted* or *vertical* position (and vice versa) until the user has assured himself that any errors introduced by this position will be negligible. This applies especially to the indicating instruments in portable test equipment and to those mounted either in an inclined position or vertically on shop test panels.

In checking a representative group of servicing instruments, it was found that the errors of indication in some are in-

(Continued on page 236)

Fig. 5.—A meter may be checked for balance by holding it in several positions and noting if it remains at zero in each one. Even if it is reasonably good in this respect, more accurate results are likely to be obtained if it is used in the position for which it was designed by the maker.

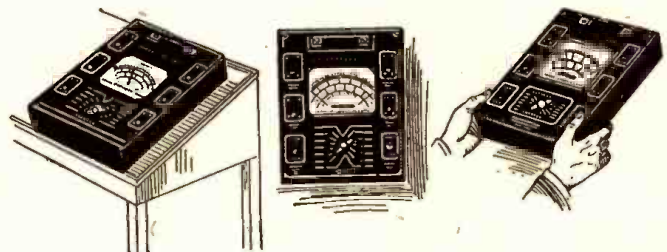

# Oscillators —

By ROBERT F. SCOTT

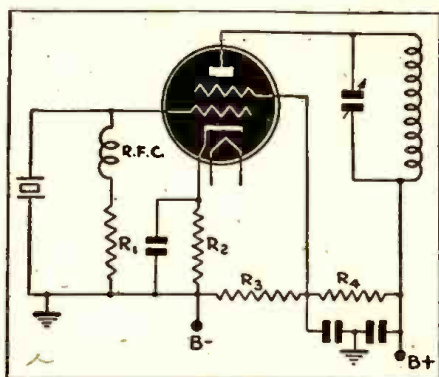

Fig. 1.—Tetrode crystal oscillator circuit. Triode crystal oscillators are even more common.

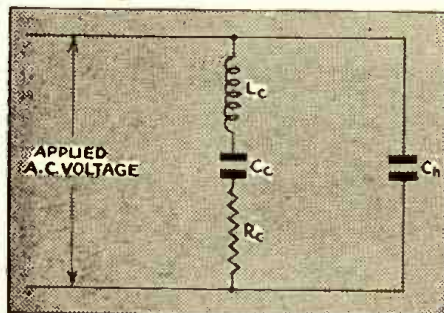

Fig. 1-a.—The crystal looks like this to the tube.

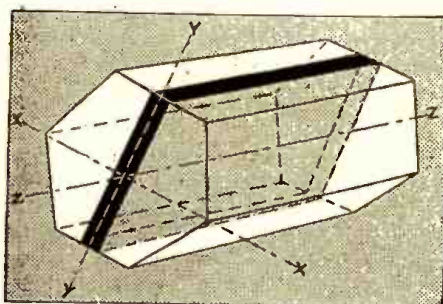

Fig. 2.—Section of a natural quartz crystal. The oscillating wafer may be cut along various axes.

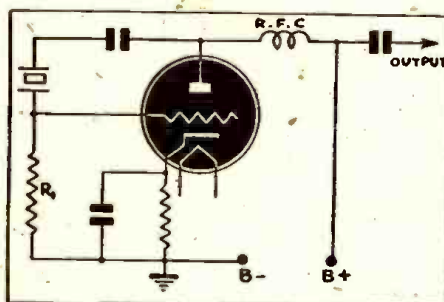

Fig. 3.—The Pierce crystal oscillator. The crystal is the only resonant element in this circuit.

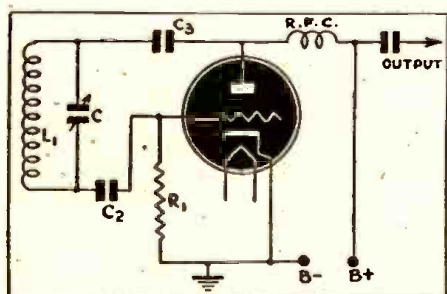

Fig. 3-a.—The Ultra-audion circuit. RFC in the two figures above is incorrectly shown between plate and output condenser instead of in the B-plus lead.

VOLTAGE changes on the plate of a vacuum tube oscillator result in frequency changes. It is easy to understand why the oscillator power supply must be able to supply the necessary current without undue loading and have excellent regulation. The resistance of the grid tuning circuit must be low so that there will be no excessive loss of grid voltage.

Lowering the radio-frequency resistance in a coil by the use of low-loss forms, low resistance coil windings, short leads to grid and tuning condenser are all worthy steps in maintaining a high efficiency in the circuit. The efficiency of a tuned circuit is measured in terms of "Q." The "Q" of a parallel resonant circuit is determined from the formula,

$$"Q" = \frac{2\pi FL}{R}$$

when:

F = frequency

L = inductance

R = total A.C. resistance, plus skin losses and external reflected loads.

$2\pi = 6.283$  approximately

The absolute frequency of a vacuum tube oscillator R may be theoretically determined from the formula,

$$F = \frac{1}{2\pi} \sqrt{\frac{1 + R/R_p}{LC}}$$

From the formula, we can see that a small value of R with the maximum value of  $R_p$  should be used to compensate for slight changes in circuit constants. The product of LC is constant for each frequency but the ratio between the two is variable. A low inductance will be small physically and this may be built to have a low ohmic resistance, low distributed capacity and low high-frequency resistances. A large value of C will result in using a condenser that can be built ruggedly and will be least effected by mechanical shock and vibrations. Any changes in capacity due to vibrations will be only a small part of the total capacity and therefore the frequency changes will be slight.

## QUARTZ CRYSTAL OSCILLATORS

For maximum stability in oscillators it is imperative that maximum "Q" exist in the tuned circuits. The maximum "Q" obtainable in a self-excited oscillator does not insure sufficient stability to warrant its use in controlling the frequency of broadcasting stations or other transmitters for commercial or public use, or for use as frequency standards or precision radio receivers.

A natural quartz crystal may be cut so that it can be made to vibrate on only one frequency. This crystal, when inserted in a suitable holder, and substituted for the usual tuned inductance in the oscillator grid circuit, will cause the tube to oscillate at a frequency equal to the natural vibration frequency of the crystal. An oscillator controlled in this manner is very stable and is called a crystal oscillator.

Figure 1 shows a tetrode tube used as a

crystal oscillator. Omitting the screen grid from the tube, the circuit will function as a triode crystal oscillator. This type of circuit functions just as a tuned-grid-tuned-plate oscillator. The electrical equivalent of a crystal in an electrical circuit is that of a very high inductance in series with a very small capacitance and some resistance. When the crystal is mounted in the holder, a shunting capacity is developed by the plates of the holder on both sides of the crystal. The electrical equivalent is shown in Fig. 1-a.

The best crystals are cut from Brazilian quartz, that may be found in naturally shaped prisms similar to Fig. 2. This prism has three principal axes. The axis parallel to the length of prism is called the optic axis and a perpendicular to the natural edges of the prism is called the electrical or "X" axis. An axis perpendicular to the others is called the "Y" axis.

A thin wafer is cut from the prism with thin edge parallel to the X axis. The other edges are parallel to the Y and optic axes. The thickness of the crystal may be only a few thousandths of an inch.

If a potential difference is applied to the faces of the crystal that are perpendicular

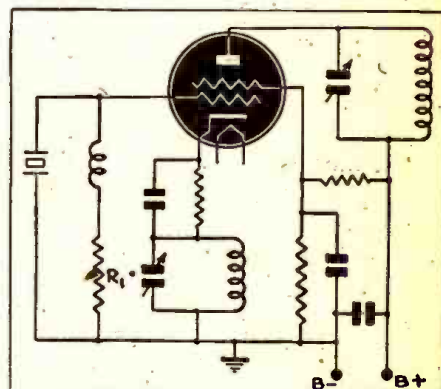

Fig. 4.—Grid-plate oscillator. The "plate" of this circuit is the screen-grid of the tetrode.

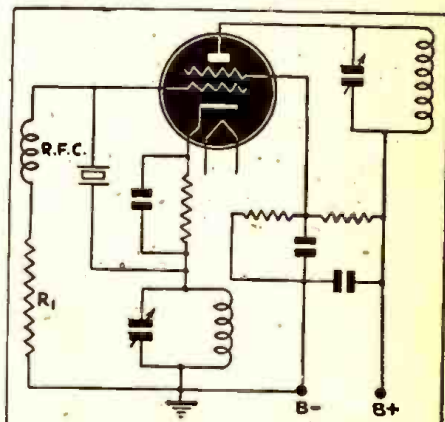

Fig. 4-a.—The famous Tri-Tet, which enables the tube to oscillate at twice the crystal frequency.

# How They Work

(SECOND OF A SERIES)

to the X axis, the crystal will contract along the Y axis and expand along the X axis. A reversal of the applied potential will cause the crystal to contract along the X axis and expansion will take place along the Y axis.

Conversely, if pressure is applied to the Y axis, the X axis will expand and a potential difference will be found along the X axis. If an alternating voltage is applied along the X axis, the crystal will contract and expand along this axis and at the same time it will also be expanding and contracting along its Y axis.

When a crystal is placed in the grid circuit of an oscillator and a positive potential is applied to the plate, a voltage will be placed upon the grid due to the interelectrode capacitance between grid and plate. This potential that is placed upon the grid will also be present upon the top surface of the crystal. The presence of this charge will cause the crystal to either contract or expand along the X axis. Assuming that the charge causes the crystal to contract along the X axis, it will also cause it to expand along the Y axis. When this charge is reduced or removed, the crystal will have a tendency to return to its normal shape. As the crystal is contracting along the Y axis, a potential difference will exist between the surfaces of the crystal holder. This charge will be opposite in polarity from the charge that would cause the crystal to expand along the Y axis.

The voltage potentials developed by the expansion and contracting of the crystal will have the correct polarity to sustain oscillation. The losses that occur in the grid circuit are replaced by feedback due to interelectrode capacity.

## SOME CRYSTAL CIRCUITS

Fig. 3 illustrates one of the most simple of the crystal oscillators in common use. This is the Pierce oscillator and is easily recognized by the fact that the crystal is placed between the plate and the grid and that the plate circuit is untuned. The Pierce oscillator has its counterpart in the Ultra-audion. (Fig. 3-a). The plate-to-cathode and grid-to-cathode capacitances supply the necessary out-of-phase voltage to sustain oscillation. In the Pierce oscillator, the grid leak supplies additional bias to the grid after the tube has started to oscillate.

The grid-plate oscillator and the Tri-tet oscillator (Figs. 4, 4-a), are modifications of the tuned grid tuned plate crystal oscillator. They assure harmonic output and greater frequency stability with varying loads.

The output of an oscillator is not as high as an amplifier with the same electrode potentials because from 10% to 25% of the available output power has to be fed to the grid circuit to sustain oscillations.

Crystals have been found to have different characteristics when they are cut at various angles to the optical, mechanical and electrical axes. The crystals differ in temperature-frequency coefficient, power sensitivity and thickness for a given frequency. The chief cuts are known as X, Y, AT, V, and LD.

The thickness of the crystal is the frequency determining factor.

The oscillation frequency of a crystal will change with the temperature due to the expansion and contraction that will accompany temperature changes. The amount of frequency change per megacycle per degree  
(Continued on page 234) \*

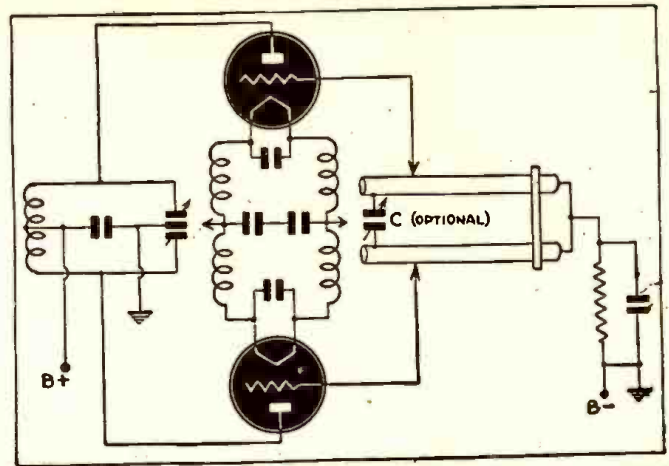

Fig. 7.—A hybrid circuit. Under some circumstances this is a more convenient hook-up to work with.

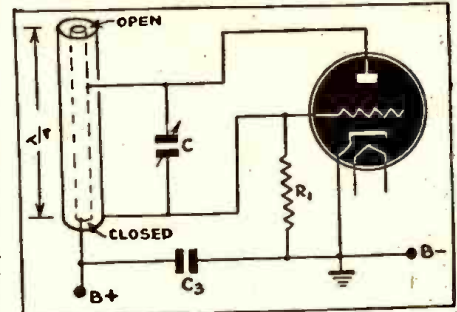

Fig. 8.—Some of the best parallel-line circuits use co-axial elements, as the Ultra-audion above.

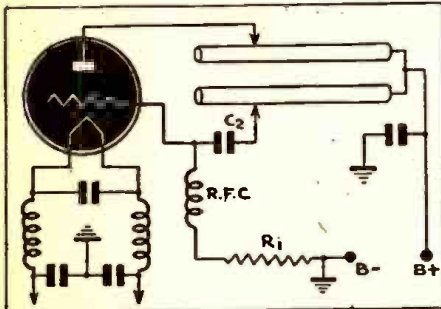

Fig. 6.—Parallel lines used in the oscillator circuit make for stability at high frequencies.

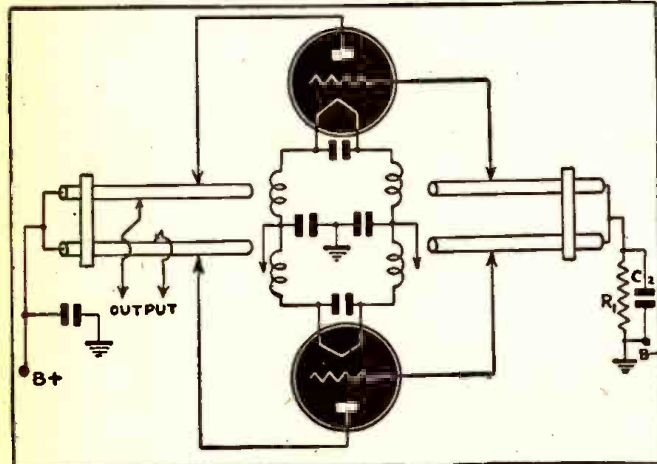

Fig. 6.—The parallel-line system used in a push-pull circuit. This "high-frequency plumbing" has become very popular for wavelengths between one and five meters. Above that, coils are less cumbersome; below, the wave-guides are found more efficient.

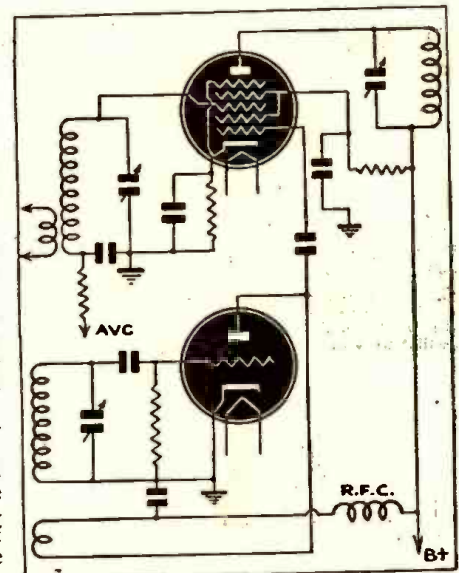

Fig. 9.—The superheterodyne converter circuit, using one tube as oscillator and another as mixer.

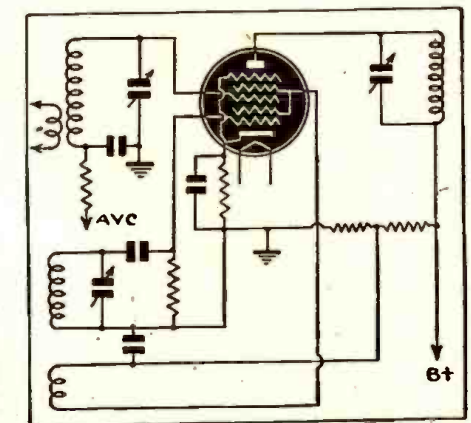
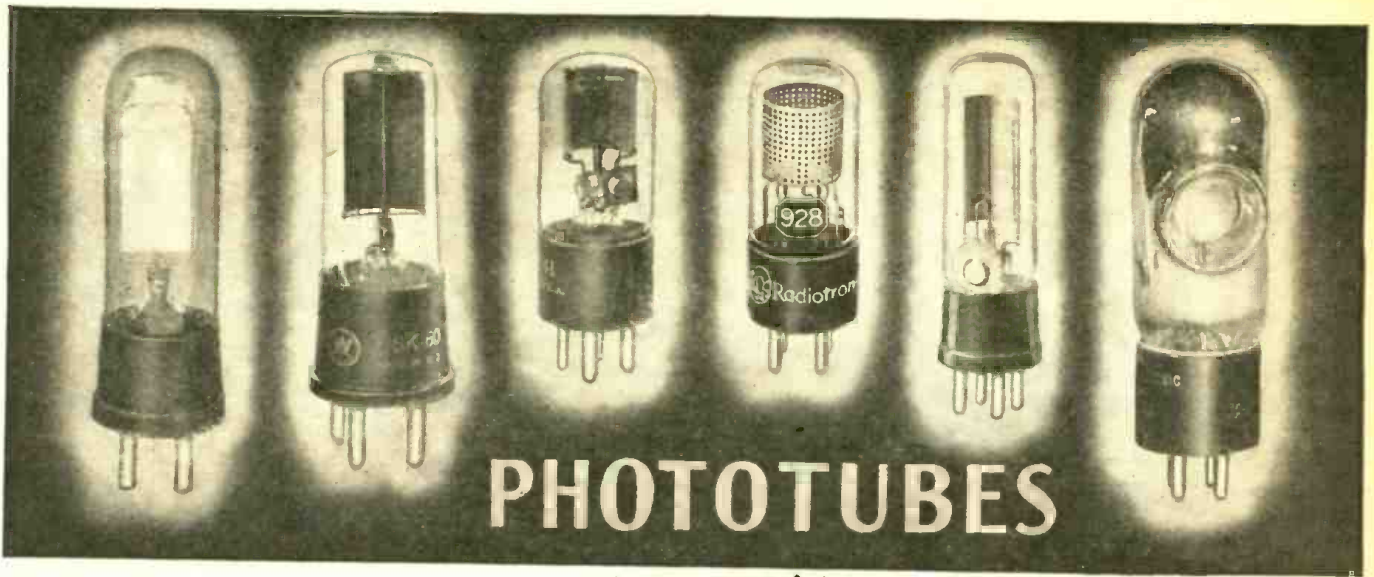

Fig. 9.a.—The superheterodyne converter circuit with a combination tube, which is both oscillator and mixer. This pentagrid converter may be a 6SA7.



# PHOTOTUBES

**T**HE electronic tubes so far described in this series have all depended on a hot cathode for their supply of electrons. The hot-cathode is by no means universal, and we even find tubes in ordinary radios which do not use it. Old-timers will remember the first Raytheon rectifiers, which were used in "B" eliminators and in some of the earlier A.C. sets. The OZ4-G is a modern representative of this group.

Such rectifiers depend upon the shape of their electrodes and the gaseous atmosphere of the tube for their properties. The phototube works on an entirely different principle. Its cathode emits electrons when struck by a beam of light. Although such a cathode is by no means as efficient as one which is activated by heat, its ability to translate light into electric current makes it applicable to a wide variety of uses. It is to light, indeed, what the microphone is to sound.

More than one type of device has been—and still is—used as a pickup for light signals. The oldest of these is the well-known selenium cell. In its simplest form, it is a quantity of crystallized selenium placed between conductors. In darkness, its resistance is very high, but when light falls on it the resistance drops to a low value. To use such a cell, it is only necessary to hook it up in a circuit with a battery and a relay. Voltages and relays are so chosen that when the light reaches a given intensity, enough current flows through the cell to actuate the device associated with it.

These cells have been known for years, but due to non-uniformity and slow action, have not found a large number of applications.

The modern photocell is a genuine electron tube. Like other such tubes, it has a cathode which, under certain conditions, emits electrons. These travel through either a high-vacuum atmosphere or one containing a small quantity of some gas, to a positively charged anode. The plate current is likely to be a few microamperes, instead of milliamperes, as in the average receiving tube, or amperes, as in the case of industrial rectifiers.

The cathode of a phototube differs from that of the heated type in that light rather than heat is required to release electrons from its surface. As certain metals and minerals release electrons more readily than others under the influence of heat, so there are metals which release electrons very readily when struck by rays of light. These electrons—literally kicked out of the surface of the metal by the impact of the light-rays on it—would normally settle

back into the atoms from which they had been expelled, were there no positively charged body near. If a positive voltage is placed on the anode, they tend to drift toward it, as in any other type of electron tube.

Lithium, Sodium, Potassium, Rubidium and Caesium are the chief "light-sensitive" substances, though many others are sensitive to a limited extent, and the first discovery of photo-electric effects (by Hertz, in 1887) was made with surfaces of ordinary zinc. Each of the metals mentioned above are relatively sensitive, and release large numbers of electrons when acted upon by light.

The strength of this current depends on the amount of light falling upon the cathode. Thus the electronic phototube can be modulated. If light is varied at voice or music frequency, the modulated beam may be picked up by a phototube and its output fed into an audio amplifier, which will reproduce the transmission.

Special methods of building up the cathode are employed. These consist usually of covering a backing plate of some metal with an oxide of the active element, and then spraying on this oxide coating a thin film (in the order of one molecule thick) of the pure active metal. If the metal film becomes thicker, sensitivity goes down rapidly.

Two things govern the choice of a cathode material—the sensitivity of the metal and the particular frequency band to which it responds. Most of the highly photo-active

substances show a sharp rise in sensitivity toward the high-frequency, or violet end, of color spectrum. The greatest sensitivity of a number of them is actually in the ultra-violet region outside the visible light spectrum. One metal—caesium—has a sensitivity curve much like that of the human eye, and is therefore particularly useful wherever light as it would be viewed by the human observer is to be measured.

In other applications, notably for industrial control, where a tungsten lamp is likely to be the source of light, photocells most sensitive near the red end of the spectrum may be used. As a matter of fact, the ordinary tungsten lamp puts out more energy in the infra-red region just beyond the visible-light band than it does at any point inside the band itself. Unreasonable as it may seem, the tungsten lamp is an excellent black-light device! Other types of lamp peak in the ultra-violet region, with high sensitivity to blue light. Some of these tubes may be used in applications requiring ordinary daylight, while others are better adapted to the mercury-vapor light of the photograph studio, rich in ultra-violet radiation.

Besides their classification according to light sensitivity, there is another important division among phototubes. Some tubes contain a slight amount of inert gas—others a high vacuum. The gas type, because of ionization of the gas atmosphere, produce larger currents for a given amount of light

(Continued on page 241)

G-E PHOTOTUBES							
Type	Description	Spectral Region of Maximum Response	Typical Sensitivity Microamps per Lumen	Maximum Operating Volts	Surface	Maximum Current Microamps	
PJ-22	Vacuum	Infrared	14	200	Caesium	20	
PJ-23	Gas	Infrared	50	90	Caesium	20	
FJ-401	Gas	Blue	7 (4,000 A)	90	Rubidium	10	
FJ-405	Vacuum	Ultraviolet	12	200	Sodium	50	
GL-441	Vacuum	Blue	45	200	Caesium	20	
GL-917	and						µa per sq. in.
GL-919	Vacuum	8,000 A	20	500	S-2	152	
GL-921	Gas	8,000 A	135	90	S-2	152	
GL-922	Vacuum	8,000 A	20	500	S-2	152	
GL-923	Gas	8,000 A	135	90	S-2	102	
GL-927	Gas	7,500	125	90	S-1	101	
GL-929	Vacuum	3,750 A	45	250	S-4	102	
GL-930	Gas	8,000 A	135	90	S-2	102	
WESTINGHOUSE PHOTOTUBES							
SR-50	Vacuum	Deep red—violet	15	500	Cs-0	20	
SR-53	Vacuum	Deep red—violet	25	500	Cs-0	20	
SK-60	Gas	Deep red—violet	60	90	Cs-0	20	
SK-63	Gas	Deep red—violet	125	90	Cs-0	20	
WL-784	Vacuum	Deep red—violet	15	500	Cs-0	20	
WL-735	Gas	Deep red—violet	60	90	Cs-0	20	
WL-737	Gas	Deep red—violet	60	90	Cs-0	20	
WL-741	Gas	Deep red—violet	100	90	Cs-0	20	
WL-770	Vacuum	Near u.v.	0.75	500	Cs-Mg	2.5	

Characteristics of a number of typical phototubes.

# We Learn the Hard Way

In an interesting step-by-step presentation, beginning from the crudest imaginable circuit, the author shows what makes a filter circuit tick. Well worth reading by beginner or expert.

By JAMES LANGHAM

It was quite a while back. We wanted more gain so as to operate our recorder with a really nice microphone we had promoted. "I," I announced in clear ringing tones, "I will design and build a preamplifier."

That was fine. That was very nice. We used a nice new 6SJ7 tube and one of the very small UTC input Xformers and—right there we stopped. Wait a bit, we said. If we operate a regular power supply with a power transformer and a filter choke we

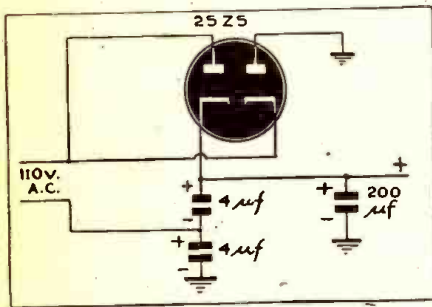

Fig. 1—The original voltage doubler circuit.

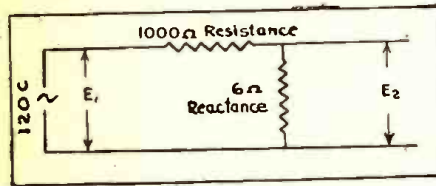

Fig. 2—Equivalent circuit of the filter.

will put out a field that will be too big for that little input transformer to jump over. We don't want hum and we don't want to spend dough for a great big permalloy shield to put around the Xformer—so we could leave off the power supply and run a cable with filament and B voltages from our main amplifier and that way we could.

"Uh-uh." The XYL shook her head. "We don't want a mess of wires around all full of high voltage and stuff. You build it with its own power and then we can plug it in over here."

That sounded reasonable. I liked to think of myself as a radio engineer in those days (I still like to but I rarely can now.) and I felt it should be possible. No induced hum in the input meant no power transformer or choke could be used. Well, we could use a full wave voltage doubler such as a 25Z5 and a 12SJ7 as our amplifier tube. If we didn't use a choke we would have to throw a lot of condenser from B plus to ground to avoid hum but we thought that was all right. We could get a couple of those new cans with two 30 mike and one 40 mike section.

Fair enough. We promoted an aluminum ice tray for a chassis (aluminum is fine stuff for high gain low level circuits) and punched and drilled holes and mounted

parts and wired up. (Fig. 1.) Then we called the XYL and had her sit down to listen to the best doggone preamp ever made.

Ooooooh! Did it hum! We could hear voice over the hum if we shouted right into that lovely ribbon mike but just barely. In fact it was hard to hear the XYL as she complained (loudly and bitterly) about the loss of an ice tray.

Something was wrong, I decided. I had butched somewhere. A quick check showed all the wires going where they should—another showed the hum was 120 cycle not 60. That narrowed it down to the filter. I had 200 mikes from B-plus to ground and it hummed like Hades.

Must need more capacity, I thought, so I rigged up another 200 mikes and tried again. Down a wee bit but the hum was so loud you still couldn't hear signal unless we shouted. It was a crisis—you might say.

After the XYL had retired (huffily) we sat down and tried to reason it out. Disconnecting the B plus and running a lead over to the main amplifier for high voltage we tried again and found no hum at all. Hum was considerably lower than tube hiss. It must be that filter. Suddenly it dawned on us. What we wanted was a voltage divider. Not just capacity thrown across the line but a regular AC divider that wouldn't disturb the DC.

We drew a simple divider circuit. (Fig. 2.) A resistor in series with the B and another resistor from B to ground. The resistor to ground was the impedance of our condenser. An impedance that varied with frequency.

$$X_L = \frac{1}{2\pi f C}$$

Our series resistor from B plus to the top of the condenser was a resistor which stayed the same. Say 1000 ohms.

Now then, we said, if we draw 1 MA that means we will lose only one volt of DC. The voltage divider would have very little to do with DC. 1000 ohms in series and practically an open circuit across, say 100,000 ohms. But at 120 cycles we would then have 1000 ohms in series and—let's see—one over two pi times 120 times 200 microfarads would be about 6 ohms. A series resistor of 1000 ohms and then a parallel impedance of 6 ohms. That would mean our 120 cycle hum would be down by the rate of 6/1006, or about .6 of 1%. Let's try it and see.

We did. We inserted a 1000 ohm resistor just ahead of our filter can and flipped the switch. Hum? Yes it hummed but not badly. Signal was way above it.

Now then, we said, if we put in 2000 ohms we will lose 2 volts of DC and the hum will be down .3 of 1%. We tried that and it was. Almost okay in fact.

Then our brain got working again and this time we said: suppose we use 2000 ohms again but this time let's do it differently. Let's split our condenser into two units of 100 mikes apiece and use 1000 ohms

ahead of each can. Reactance of 100 mikes at 120 cycles is about 12 ohms so we would have two voltage dividers. One would attenuate the ripple by 12/1012 and the other would attenuate that by 12/1012. The first would cut the ripple from 100% down to 1.2% and the second would put out only 1.2% of that. In other words we would have .014 of 1% ripple. We tried that and it was practically perfect. (See the circuit in Fig. 3.)

Let's go whole hog this time, we said, and split it up properly. This time we put a 450 ohm resistor (to make our ratio come out nicely) in series with the first section of 30 mikes (reactance about 45 ohms), then another 450 ohm resistor and then another 30 mike section, then a 330 ohm resistor and then the 40 mike section (about 33 ohms reactance), then a 1200 ohm resistor and the 100 mikes of the second can. (Fig. 4 shows how it's done.)

What we had there was this: For DC, we had a total series resistance of 2430 ohms which meant that with one milliampere drawn by the pentode we would lose 2.43 volts from our 215 volt supply. We would have 212.57 volts left. As far as AC was concerned we had 450 ohms in series then 45 ohms to ground which reduced our hum to 9% then another 450 series and another 45 to ground which reduced it to 9% of 9% or .8% then a 330 ohm series resistor and 33 ohms to ground which made it 9% of .8% or .07 of 1% and then 1200 ohms series and 12 ohms to ground which brought us down to 1% of .07 of 1% or .000007 times our original hum.

There we were. Our hum was down to nothing. We ran the gain up all the way and heard a little tube hiss. Just then the XYL wanted to know when we were coming to bed. She spoke in a normal voice and didn't know the gain was up but the headphones nearly jumped off my ears. I had thoughts of being a 4-F for a while but my ears cleared up all right in about a week.

As we say, we learn the hard way. Now we believe in low pass filters that have a slope of 6 DB per octave per section.

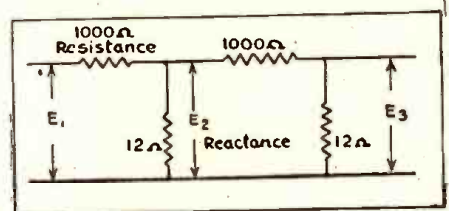

Fig. 3—An intermediate evolutionary step.

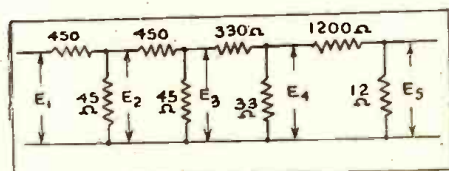

Fig. 4—Equivalent of the completed filter.

# TRANSMITTERS *for* FM

**I**n the two preceding installments we brought to light the most common methods of frequency modulation transmission. Both reactance and phase modulation were described. We shall now indicate the method of converting this frequency modulated signal back into an audible signal.

Two block diagrams are shown in Fig. 1; at 1(a) the diagram of an AM receiver, and at 1(b) the block diagram of an FM receiver. From the figure it is plain that both receivers are identical up to and including the I.F. amplifier. Although the stages employed are the same, there are

the band-pass of the receivers at this same figure. Band-pass is accomplished, of course, in the I.F. section of any receiver, but the method used to tune the R.F. stages of the receiver will greatly influence its pass-band. Manual tuning of an FM receiver is practically out of the question, because the operator cannot pick out the middle of each channel with any great deal of accuracy. It is therefore customary to employ preset tuning of the R.F. stages. Push-buttons are

So far the stages of the FM receiver conform exactly to the corresponding AM receiver except for the differences listed.

## THE LIMITER STAGE

FM is noted for its noise-free reception, and this merit is due solely to the operation of the limiter stage or stages. Remembering that the transmitted signal manifests the audio intelligence it carries in the *frequency shift* of the R.F. carrier; it is quite evident that any alteration in the *amplitude* of the carrier may be made before detection without affecting the audio component. It is also evident that the *noise* tends to amplitude modulate any signal and these noise variations manifest themselves as amplitude variations on the modulated wave. With these basic points in view the analysis of the limiter follows.

There are two basic limiter circuits in use in modern FM receivers; the *overload* limiter, and the *feedback* limiter. The schematic of the overload limiter is shown in Fig. 3. The output of the I.F. amplifier is coupled to the grid of the limiter by means of the I.F. transformer T1 which is of the type described in the paragraph on the I.F. amplifier. Resistors R1 are used to flatten the transformer's response over the desired channel width. The limiter tube is a sharp cutoff pentode to obtain the desired action. It can also be seen that the plate voltage is lower than that of the screen grid by the additional drop across R2; the screen grid voltage is obtained by the voltage drop across R3. The control grid return is made through grid leak R, which is by-passed by C, therefore with low screen and plate voltages and grid bias the tube will overload very readily.

The dynamic characteristic of the overload limiter is shown in Fig. 4(a). Here is pictured an input signal which overloads the tube. The action is, as follows: as the positive half cycle proceeds the plate current  $I_p$  rises to saturation flattening off or clipping the peak (shown in dotted lines) of the positive half cycle; also it is seen that on the positive half cycle the grid goes positive, which means that it draws current over this period. This grid current flowing through R produces a voltage drop across it and the combination of R and C have a time constant which is high enough to maintain this grid bias over the negative half signal cycle. As the input signal swings to the negative half cycle the grid voltage decreases to plate current cutoff and the negative half cycle peak is clipped. Since limiting is accomplished by plate current saturation on the positive half cycles of the input signal and plate current cutoff on the negative half cycles, the overload limiter is sometimes referred to as the saturation cutoff limiter. The selection of plate and screen voltages and grid leak combination R and C will determine the input signal voltage amplitude at which limiting will start. With high screen and plate voltages and a high value of R limiting will occur only on strong input signals; with lower screen and plate voltages and a low value of R, limiting would occur on weaker input signals.

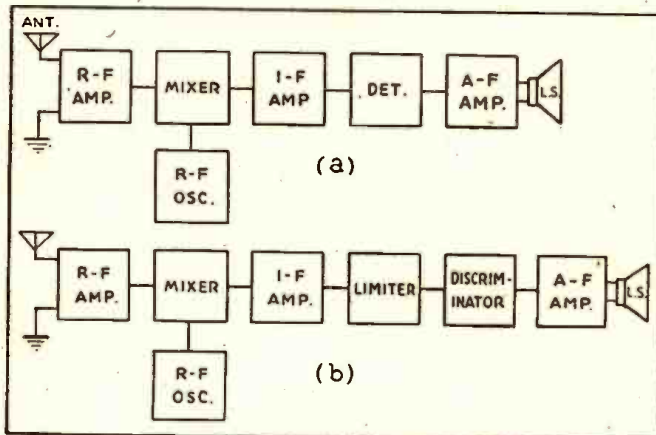

Fig. 1.—The AM and FM receiver compared by means of a block diagram. It will be noted that the two are organically similar through the I.F. stage. The limiter is peculiar to FM receivers, and the discriminator is equivalent to the detector of the AM set.

some pertinent differences in the characteristics of these stages. In high-fidelity FM broadcast the band used is 40 to 50 Mc. This means, of course, that the R.F. amplifier, the mixer and the R.F. oscillator tuned circuits must be capable of covering this frequency range. Operating at this high frequency also means that the R.F. oscillator constants must be exact to insure stability. A crystal controlled R.F. oscillator is employed in many commercial FM receivers. In most broadcast FM receivers the C.C.O. is not practical, and the next best thing has to be used; the electron coupled oscillator. In this high channel the I.F. will also have a much higher value for more stable operation, and I.F.'s from 2 to 5 Mc. are found in FM receivers, to reduce image responses and "pulling" of the oscillator.

In the FM broadcast a channel width of 150 kc. is used. This automatically sets

used and the middle of each channel is set by instruments. The setting of FM push-buttons will be discussed in a later installment. In some cases automatic frequency control of the R.F. oscillator is employed to insure against frequency drift, but this depends upon the particular design.

## I.F. AMPLIFIER CIRCUITS

In this channel a decisive break with AM methods is made; the band-pass of the I.F. circuits broadened out to accommodate the 150 Kc. width of the modulated signal. This means an alteration in the design of the I.F. transformers of the receiver. First the windings of the transformer are tightly coupled (over-coupled) to broaden the response to a value slightly greater than the expected transmitter swing. Second, high values of resistance are shunted across either primary, secondary, or both, depending upon the design of the transformer. The purpose of such alterations is to make the response flat over the channel width.

An I.F. transformer used for AM and one used for FM reception are compared in Fig. 2. The primary and secondary of the I.F. transformer T1 are slightly over-coupled to produce the 10 kc. response curve shown below the transformer. T2 has its primary and secondary very tightly coupled to produce the resultant 150 kc. band-pass. With such a band-pass a decisive double-hump effect is seen. The double-hump effect is smoothed out by loading the primary and secondary with a high value of damping resistance. It is quite evident that tuning T2 too sharply would result in cutting off some of the frequency deviation. This would result in serious distortion. Alignment of the I.F. transformers of an FM receiver is a special job and will be discussed in detail in the next installment.

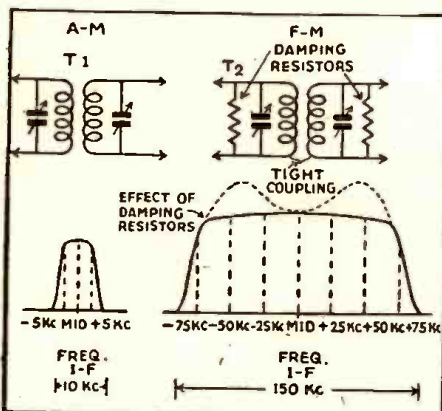

Fig. 2.—I.F. transformers for AM and FM compared.

PART III

This action is shown clearly in Figs. 4(b) and (c). In 4(b) is shown the clipping action on a moderately strong FM signal with a large R and a high Eb and Es<sub>g</sub>; six cycles of the FM signal are shown. The amplitude variation of the signal is due to noise peaks present. Cycles 1, 2 and 3 overload the limiter by driving the plate current to saturation and grid bias to plate current cutoff; therefore, complete limiting is accomplished and the noise variations are eliminated; however, cycles 4, 5 and 6 do not overload the tube and these three cycles are merely amplified with a large portion of the noise still present. For such signals the limiter is essentially an I.F. amplifier.

Feeding the output at (b) to the detector would naturally result in the noise peaks coming through the audio section to the output of the receiver. Perfect limiting is not accomplished. In (c) is shown the action of an additional overload limiter with a small R and lower Eb and Es<sub>g</sub>, so that cycles 4, 5 and 6 are clipped, and since all six cycles overload the tube, complete limiting is accomplished. In the better receivers two such limiters are used in cascade; the first limiter clips the peaks of stronger signals above some predetermined value, by using a large R and high Eb and Es<sub>g</sub>; the second limiter simultaneously clips the weaker signals above some predetermined value by employing a low R and lower Eb and Es<sub>g</sub>. Complete noise elimination is thus accomplished.

The newest method of limiting (feed-back limiting) eliminates the use of two cascaded limiters, but two stages of I.F. amplification must generally be used to provide the necessary signal strength. The schematic of the feedback limiter is shown in Fig. 5. It can be seen from the diagram that the only change which has been made is that, instead of returning the cathode of the limiter directly to ground, it is returned through an iron core inductance L1 to ground. L1 is by-passed for R.F. by C1. The inductance of L1 is very high (about 10 henries). C1 has a value of about 100 μfd. This combination will give the cathode circuit a relatively high time constant for audio frequencies. Since noise peaks tend to amplitude modulate the R.F. wave, and the average plate current of the limiter conforms to the envelope of the R.F. wave, any change in the envelope due to noise

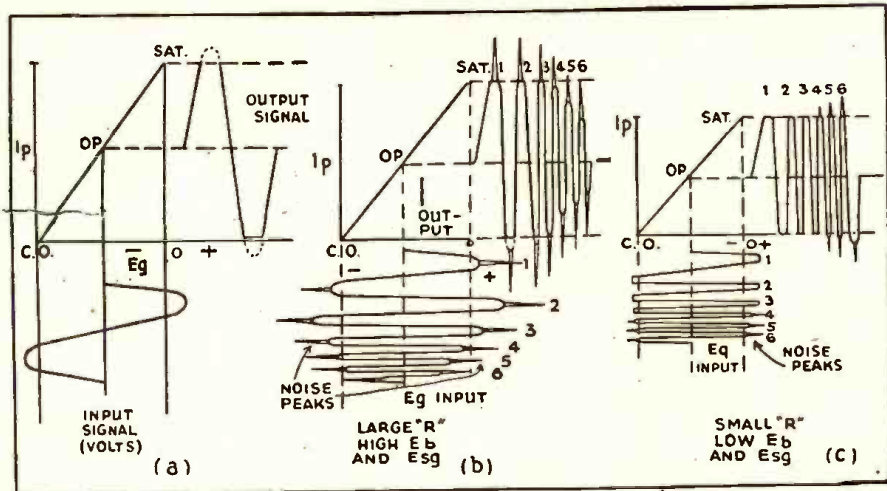

Fig. 4.—How the limiter works. The action with large and small signal inputs is shown for high grid resistance and high voltages at (b), and for smaller voltages and lower resistance at (c).

will assume the form of a ripple in this average plate current. The plate current return is to the cathode, so this average plate current flows through L1. If it varies at an audio rate voltage drops will occur across L1 as this average changes due to amplitude variations in the R.F. wave. The grid of the limiter is returned through grid leak R to the negative side of L1, thus, if the noise modulates the R.F. in the audio range the average plate current changes at an audio rate. As L1 presents a high reactance to audio changes in current, voltage drops will occur across it in direct opposition (inverse) to these changes, and tend to smooth out this plate current ripple by increasing the grid bias at these intervals.

For signals that are above a predetermined value overload limiting is accomplished in the manner previously described. As the signal strength drops below the predetermined value feedback limiting takes over simultaneously, and provides complete limiting. This action is shown in Figs. 6(a) and (b). At 6(a) is shown the action of the feed-back limiter as an overload limiter; however, the only peaks which are clipped are 1 and 2. The average plate current  $I_p$  presents itself as an A.C. ripple at this point (cycles 3 to 6), feedback limiting occurs and smooths out the ripple. Fig. 6(b) shows how the grid bias  $E_g$  is altered in proportion and in opposition to the changes in average plate current flow  $I_p$ . When the plate current variation is in the positive direction the voltage drop across L1 increases and makes the grid  $E_g$  more negative, thus cutting the plate current down to an average value again; when the plate current variation is in the negative direction the drop across L1 increases in the opposite direction, making the grid  $E_g$  less negative by the same amount and the

plate current  $I_p$  increases back to an average value. Where overload limiting leaves off, feed-back limiting starts simultaneously.

Any combination of overload and feed-back limiting may be used, depending upon the design of the receiver, but both methods will do the job—remove the amplitude variations from the FM signal. From the illustrations given it is evident that the final output of the limiter, of either type, will tend to be a flat-topped wave; this would result in harmonic distortion if fed directly to the detector; however, the output circuit of the limiter is a tuned circuit, and will round off the tops and bottoms of the wave, as it is tuned to the I.F.

Summarizing, the FM signal has come into the receiver; it has been amplified by an R.F. amplifier; it has been converted to the I.F. by being fed through the mixer and mixed with the local oscillator signal; it has been amplified at the intermediate frequency by means of the I.F. amplifier; and all amplitude variations have been removed by the limiter. We now have a constant amplitude frequency modulated signal which is ready for detection.

THE FM DETECTOR

The FM detector—like the AM detector—is the heart of the receiver. In AM this is a single process; converting amplitude variations of the carrier into audio voltage. In detecting FM signals, however, the process is two-fold; first, the frequency modulated R.F. signals have to be converted to corresponding amplitude modulation, then the amplitude modulation is detected in a normal manner. These two actions must be linear and occur simultaneously to provide the net result.

Following are three circuits which per-  
(Continued on page 253)

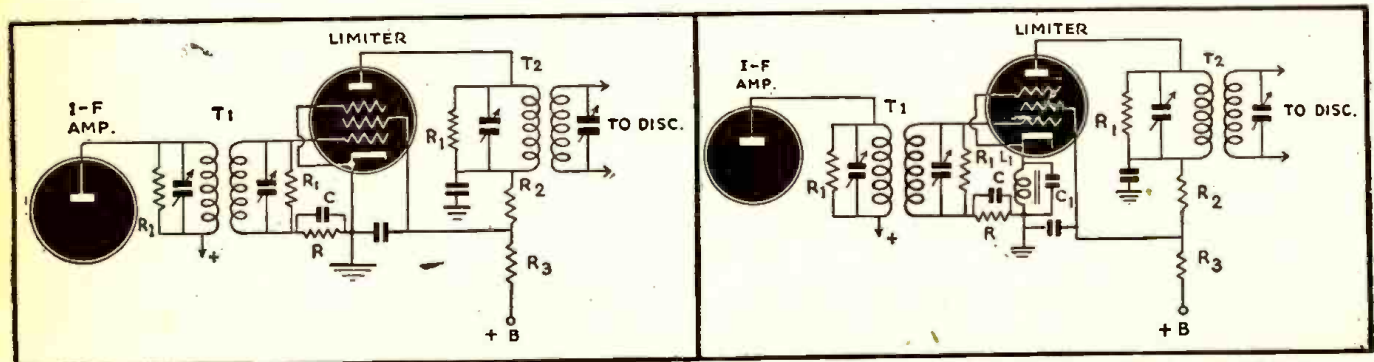
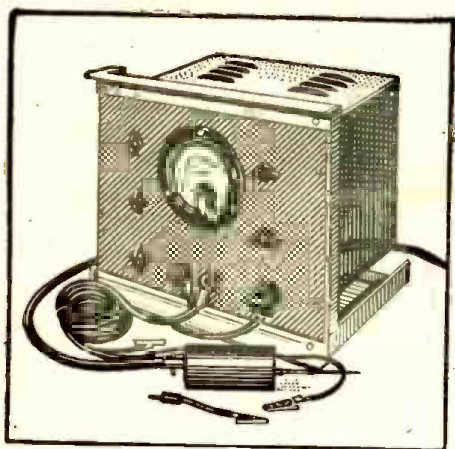

Fig. 3 (left)—Schematic of the overload limiter, and 5, (right) of the feed-back limiting circuit. The feed-back type is considered more efficient.

# A VERSATILE



Here is a single unit which measures both voltages and currents, either in A.C. or D.C. It is also an ohmmeter. Its accurate A.C. range is exceptionally wide, running from a few cycles to many megacycles.

**M**UCH routine laboratory work consists of making D.C. and A.C. voltage and current measurements, rough checks of resistance, and measuring R.F. and A.F. voltage. The instrument to be described is a single unit covering all these requirements.

The ranges covered are:—  
**Voltage, D.C. and A.C.:** 0-1, 0-100, 0-500, 0-1,000 volts.  
**Current, D.C.:** 0-1, 0-10, 0-100 Ma., 0-1, 0-10 Amps.  
**Current, A.C.:** 0-10, 0-100 Ma., 0-1 Amp.  
**Resistance:** 0-10,000 Ohms, 0-1 Megohm.  
**Electronic Voltmeter, R.F. and A.F.:** 0-1, 0-10, 0-100 Volts.  
**Electronic Voltmeter, D.C.:** 0-5, 0-50, 0-500 Volts.

A 1 Ma. meter is used for all measurements. There are two scales, the lower graduated for resistance ranges and the upper divided linearly and numbered 0-5 and 0-10 for all other ranges.

Two twelve-position switches are used for selecting all ranges (see Fig. 1). The other controls are two zero-setters for the resistance ranges and one for the tube voltmeter.

## D. C. VOLTMETER

As a 1 Ma. movement is used, all ranges have a resistance of 1,000 ohms per volt. In Fig. 2 (a), if  $V$  volts produce full-scale deflection, and the resistance of the meter movement is  $r$  ohms, the required series resistance,  $R$  ohms, is given by  $R = 1,000 V - r$ .

In the meter used,  $r$  is 118 ohms and can be neglected on all ranges except perhaps the lowest.

The meter movement alone is used for the 1 Ma. range; for 10 Ma. a shunt resistance of value  $\frac{r}{9}$  ohms is switched across

the meter and on the 100 Ma. and higher ranges a tapped shunt is used. See Fig. 2 (b). The advantage of this method is that on the high-current ranges, accuracy of calibration is not affected by variations in switch contact resistance.

Resistance values in Fig. 2 (b) are given by:

$$R_1 = \frac{r}{9,900}; R_2 = \frac{r}{1,100}; R_3 = \frac{r}{110}$$

In this case  $r = 118$  ohms, hence,  $R_1 = 0.012$  ohms;  $R_2 = 0.108$  ohms;  $R_3 = 1.08$  ohms. The figures above will give the correct values for other meter resistances.

The 10 Ma. range shunt resistance has a value of 13.1 ohms, and is made up of

double-silk-covered resistance wire of suitable size. Fig. 3 (a) gives dimensions of a suggested form, and shows the method of twisting the tinned copper wire terminal tags.

The tapped shunt resistor  $R_1$  consists of two 5 in. lengths of 16 SWG bare resistance wire in parallel, mounted on the switch wafer. The resistance is adjusted by running solder along the wire.  $R_2$  and  $R_3$  were made of No. 22 wire, cut to the correct lengths, are mounted on the same form. Fig. 3 (b). These resistors should be adjusted by comparing the meter reading with that of an instrument that is known to be accurate, rather than adjusting to calculated values.

## THE A. C. VOLTMETER

A Westinghouse 1 Ma. meter rectifier is used. See Fig. 2 (d). The D. C. output from this type of meter rectifier is proportional to the mean value of A. C. input. For a sinusoidal waveform, on which most measurements are made, RMS value =  $1.11 \times$  mean value. From the manufacturer's data, the potential drop across the A. C. terminals of a 1 Ma. rectifier is 0.9 volt, for a meter current of 1 Ma. Hence, the series resistance  $R$  ohms required for  $V$  volts RMS full-scale deflection is

$$R = \frac{V - 0.9}{0.001} \times \frac{1}{1.11} = \frac{1,000 V - 900 \text{ ohms}}{1.11}$$

Therefore,  $R$  for 10 volts full scale deflection = 90,000 ohms.

$R$  for 500 volts full scale deflection = 450,000 ohms.

$R$  for 1,000 volts full scale deflection = 900,000 ohms.

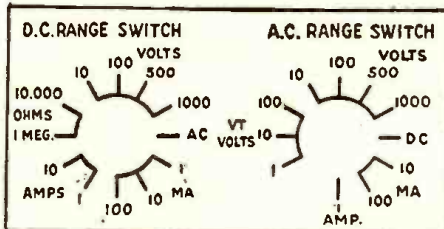

Fig. 1.—Detail of the 12-position range switches.

The 0-10 volt range should be calibrated against an accurate meter, as the scale is non-linear due to the measured voltage being comparable with 0.9 volt, the potential drop across the rectifier. From the maker's data, the output of the rectifier is uniform for frequencies up to 10 Kcs.

## ALTERNATING CURRENT METER

A current transformer is used in conjunction with the meter rectifier. Fig. 2 (e). The ranges covered are 0-10 Ma., 0-100 Ma. and 0-1 Amp.

As a current of 1.11 Ma. is required from the secondary to give full scale deflection on the meter, the turns ratios, not allowing for losses, are as follows:—

$$\begin{aligned} 1 \text{ amp. range, ratio} &= 1,000/1.11 : 1 = 900 : 1 \\ 100 \text{ Ma. range, ratio} &= 100/1.11 : 1 = 90 : 1 \\ 10 \text{ Ma. range, ratio} &= 10/1.11 : 1 = 9 : 1 \end{aligned}$$

For linear scale-shape, the voltage drop in the secondary winding should not be more than 0.1 volt. Hence the maximum permissible resistance of the secondary is  $0.1/1.11 \times 10^{-3} = 90$  ohms. To keep the secondary turns as low as possible a single turn primary winding is used on the 1-amp. range; thus the secondary turns are 900. To keep losses low the stampings must be made of a high-permeability material. A set of stampings was available with the following dimensions:—

Core,  $\frac{3}{4}$  in. square, Overall size of stamping,  $1\frac{1}{8}$  in.  $\times$   $2\frac{1}{4}$  in.

Winding area, lin. long by 0.3 in. deep.

Weight of set of stampings,  $\frac{3}{4}$  lb.

It was found that, to allow for iron loss, the secondary turns should be reduced to 880; 34 AWG ESS (enamelled and single silk) copper is used for the secondary, giving a resistance of 70 ohms. The primary windings are:—

10 Ma. range, 100 turns 34 AWG Enam or ESS,

100 Ma. range, 10 turns 26 AWG Enam or ESS,

1-amp. range, 1 turn 19 AWG Enam.

The secondary is wound on first and the other windings in the order shown above. There are two layers of Empire cloth between the secondary and the primaries and one layer between each primary. The stampings are interleaved.

## THE OHMMETER CIRCUIT

There are two ranges, covering resistance values from 10 ohms to 1 megohm. The fundamental circuit is shown in Fig. 2 (f).

If the meter, of which the resistance and full scale deflection are  $r$  ohms and  $i$  Ma. respectively, is connected in series with a resistance of value  $R$  ohms across a voltage  $V$ , then, for full scale deflection (with "Test" terminals shorted).

$$R + r = \frac{1,000 V}{i} \quad (1)$$



# TESTER

If now a resistance  $R'$  ohms is connected across "Test," then its value for half scale deflection of the meter is given by

$$R' + R + r = \frac{1,000 V}{0.5 i} \quad (2)$$

From equations (1) and (2),  
 $R = R' - r$   
 and  $V = iR' \times 10^{-3}$ .

In this instrument,  $r = 118$  ohms,  $i = 1$  Ma. and the mid-scale readings are 500 ohms and 50,000 ohms; hence the values of  $R$  are 382 and 49,900 ohms respectively; the corresponding values of  $V$  are 10.5 and 50 volts. These voltages are supplied from a line-operated power pack by means of a voltage divider network, the tapplings being variable over a small range to provide zero-ohms adjustment. The internal resistance of the supply should be small compared with  $(R + r)$  in this case, the internal resistances are 15 and 700 ohms respectively.

## ELECTRON VOLTMETER

A high-frequency diode rectifier of small dimensions, resembling the RCA 9006, is housed with its associated smoothing components in a cylindrical container; this is connected to the main instrument through about a yard of 3-conductor cable. A 6H6 would be quite suitable for all but the highest radio frequencies. A 5-pin plug and socket are used for the connection on the front panel.

The rectified voltage from the diode head is applied to a meter control tube, the supply voltages for which are taken from the power pack. A potential-divider circuit across the "B" supply voltage is used to "back-off" the meter. Fig. 2 (g). The range is changed by tapping down the diode load resistance. The standing current through the diode produces a small voltage across this resistance; this voltage applies a negative bias to the grid of the control tube, the value of which depends on the setting of the range switch. This would necessitate resetting the zero when the range is changed. Automatic compensation for this is provided by shunting the lower end of the power pack voltage-dividers by  $R_3$  on the 10v. A. C. and 50v. D. C. ranges, and  $R_4$  on the 1v. A. C. and 5v. D. C. ranges.

The D. C. ranges were originally the same as the A. C. (0-1, 0-10, 0-100 volts) but trouble was experienced when the tube voltmeter was connected across a low-resistance circuit, as this reduced the standing bias due to the diode, thus altering the zero setting. The simplest method of eliminating this effect is to use a large resistance ( $R_2$ ) in series with the input; this forms a potential divider with the diode load and therefore reduces sensitivity.  $R_2$  is chosen to give ranges to fit in with the calibrated scale: 0-5, 0-50, 0-500 volts.

As the input resistance on the D. C. ranges is high, approximately 13 megohms, the shunting effect on a high resistance source of voltage is small.

In high-resistance circuits it is advisable to measure only voltages of which the positive side is grounded; if the negative side of the source is grounded, the leakage resistance and capacitance of the high-voltage line to the chassis are shunted across the source, as the negative side must be con-

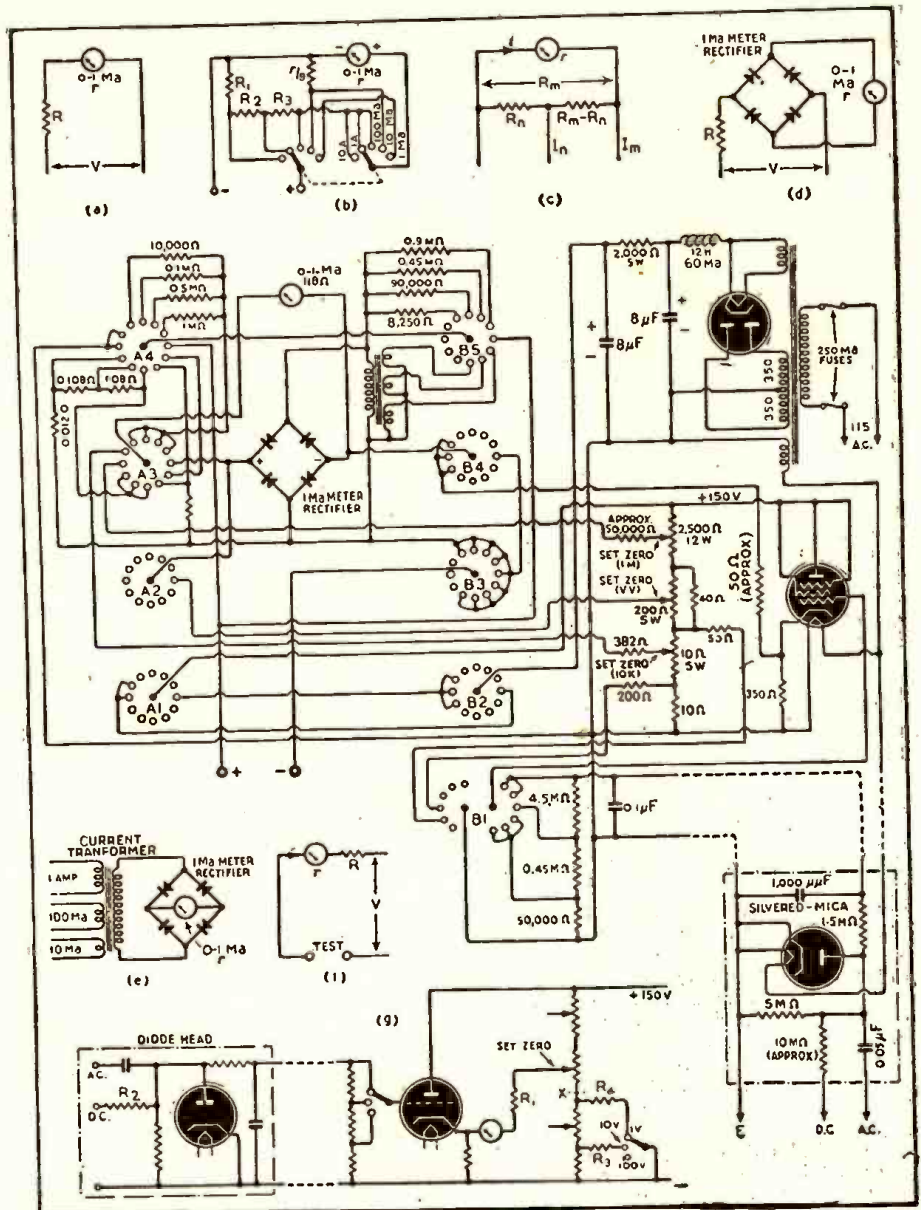

Fig. 2.—Complete circuit of the multifester. Basic circuits are shown across the top, and the complete circuit in the center. At the bottom are seen complete details of the V.T.V.M. and A.C. milliammeter.

nected to the "live" lead of the tube voltmeter.

The 10- and 100-volt A. C., and 50- and 500-volt D. C. ranges are substantially linear, and no further calibration is required. For greatest accuracy on the 1-volt A. C. and the 5-volt D. C. ranges separate calibrations should be made; this is due to the non-linear characteristic of the diode.

The frequency characteristic is flat between 50 cycles and 50 Mcs. It was not measured above 50 Mc., but the error is probably small up to at least 100 Mc. with the high-frequency diode used.

The meter control tube is a high- $\mu$  R. F. pentode, similar in characteristics to the American 6J7 connected as a triode.

If a voltage much larger than full scale is applied to the input, the current through the 1 Ma. meter does not exceed about 2 milliamperes; most meters can withstand this overload momentarily without harm.

The input capacitance of the diode head is  $7.5 \mu\text{F}$  with a short flexible lead and  $6.5 \mu\text{F}$  with a rigid prod.

Adjustment of resistors is carried out as follows:—

(1) Meter series resistance  $R_1$  to give 1v. full scale deflection on most sensitive A.C. range.

(2) Input resistance  $R_2$  to give 5v. full scale deflection on most sensitive D. C. range.

(3) Compensating resistances  $R_3$  and  $R_4$  adjusted so that the zero-setting does not change on the 10v. and 1v. A.C. ranges respectively when switching from the 100v. range.

## THE SWITCHING CIRCUITS

The complete circuit is shown in Fig. 2.

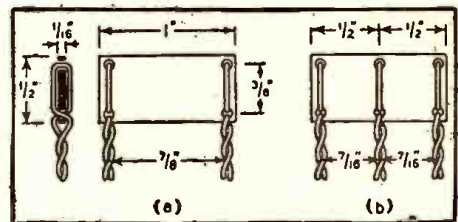

Fig. 3.—The mounting form for the shunt resistors.

It will be seen that there are two switch-wafer banks A and B. A consisting of four single-pole, 12 way units and B of one two-pole 6-way and four single-pole 12 way units. A1 and B1 are mounted nearest the

(Continued on page 237)

# Servicing Notes

## Trouble in . . .

### PHILCO TH-18

Continuous and uncontrollable oscillation, traced to the R.F. With the set turned upside down on the bench, all parts were gone over and substituted, with no results.

The trouble was found in a .005 condenser connected to the R.F. coil *above* the chassis. When shunted with another, the squeal cleared up immediately.

Although this condenser is in plain sight, it was overlooked for some time due to its being on top of the chassis.

### MIDGET SILVERTONES

These little 4-push-button models are very small and are crowded into a plastic case.

Complaint was loud intermittent buzz, disappearing when it was taken out of the cabinet.

Trouble was due to the .01 condenser from one side of the line cord to ground. When put in the cabinet, parts pressed on it, causing an apparent short to ground. Outside the cabinet it tested O.K.

RICHARD K. SMITH,  
Willow Run, Mich.

### PACKARD-BELL 46E

Annoying intermittent static and sudden volume changes may often be traced to partial opening of the I.F. transformer windings.

A quick check can be made with an ohmmeter (low-ohms range). These coils normally have a resistance between 10 and 20 ohms, but when sufficiently corroded to cause trouble the resistance is much higher.

RALPH GUNTHER,  
Los Angeles, Calif.

### PHILCO MODEL 90

(Those with one 47 in the output.) If the complaint is weak, stations fail to tune in on their correct dial settings, etc., check to see if the set has been misaligned. The I.F. for these sets is given as 260, but a number are to be found which have the I.F. transformers peaked at 175 Kc.

KENNETH NORRIS,  
Dayton, Ohio.

### REMOVING SPEAKER CONES

A lot of servicemen use acetone or related solvents, applying this with a small brush or pipe cleaner around the edge where the cone is glued to the frame. When the cement is softened they take a sharp knife and run it under the edge of the cone, gently working it loose.

I find it faster and much neater to do the job this way:

Lay the speaker face down on the service bench and run a large hot soldering iron around the edge of the metal frame. This has to be done very slowly allowing time for the iron to heat the metal, and dry out the glue which holds the cone in place. After working round two or three times you will find that the glue has dried out and the cone will drop out.

## ATTENTION SERVICEMEN!

Do you have any Servicing Notes available which you would like to bring to the attention of the readers of *Radio-Craft*? If so, send them along and if they are published a six-month subscription to *Radio-Craft* will be awarded you. If your notes are illustrated you will be given a one year subscription.

Ordinarily this may be done with a 100-watt iron, but if it is a large one it may be necessary to apply more heat than a single 100-watt iron can supply.

When replacing the cone be sure to set it so that the bolts which hold the spider will be in the right place and that the voice coil leads will come toward the transformer terminals.

J. C. CARDIN,  
Tonkawa, Okla.

(Note: We have never previously seen or heard of this method of removing cones, but pass it on in good faith as well worth trying out.—Ed.)

### KNIGHT GX

This set uses 1.4-volt tubes. It would not work with more than 45 volts "B" supply though it functioned fairly well on that voltage.

All tubes checked O.K. on an excellent tube tester.

Trouble was cleared up by replacing the 1A7-GT. It appears that more than 45 volts would paralyze this tube, causing it to stop oscillating.

F. RENNER,  
Nobleford, Alta.

## CURRENT BATTERY SHORTAGE

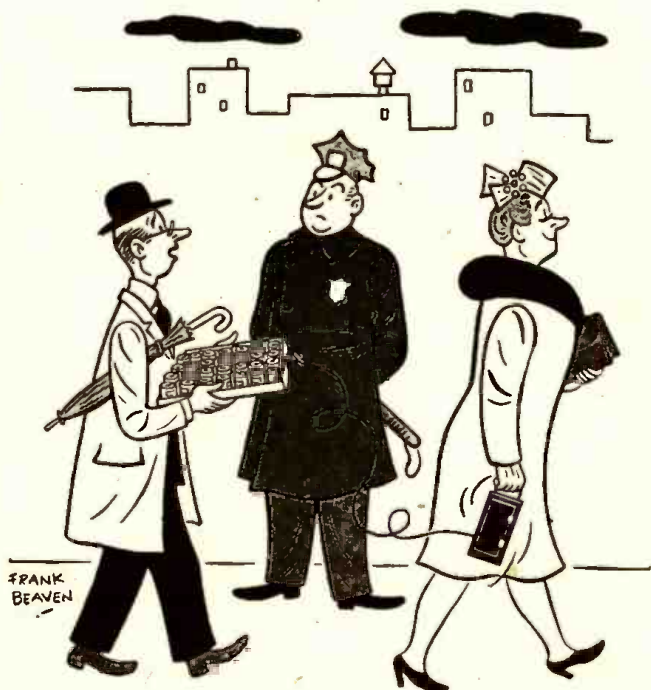

"What could I do—she insisted that I fix the portable."

### EMERSON TABLE MODELS

Complaint: No volume, low volume, fades, etc.

These cases were traced in a large number of cases to the volume control. After replacing a number I dismantled one as an experiment.

It was found that a small quantity of lubricant was placed on the shaft inside the control. Carbon dust scraped from the control surface was deposited on this, causing a partial ground. By washing the lubricant off with carbon tetrachloride the volume control worked as good as new.

Later I hit on the idea of leaving the control in place and squirting some carbon tet into it from a small clean oil can, at the same time rotating the knob to allow the liquid to wash out the entire inside of the control. The method scored 100% success—no call-backs.

E. H. MOHL,  
Philadelphia, Penna.

### RESURRECTING DEAD TUBES

Recently a serviceman suggested that open filaments of 50L6 tubes might be welded by flashing them with a high A.C. voltage.

I tried the idea on a dozen 50L6's with open filaments. A.C. from a power transformer secondary was used, the voltage being about 325. Flexible leads were used to connect to the filament prongs, one being made secure, the other touched momentarily.

In about half the cases no spark was seen. In another couple I got a spark once or twice. On four tubes the filament closed and stayed closed. I checked these tubes in a tube checker from time to time and three of them are in good condition today.

This is suggested purely as a wartime measure because of the shortage of 50L6's. I tried the scheme on 12SA7's and other 12-volt tubes, but without results.

C. D. HEWITT,  
Hamden, Conn.

### MAJESTIC MODEL 90

A puzzling case of apparent overload appeared on this model. The 80 turned blue and voltages dropped. No shorts were discoverable.

Trouble was found to be a partial short between the filament and high voltage winding inside the power transformer. As no replacement was available the tar was melted out and a repair made.

ARTHUR HAGOPIAN,  
Petaluma, Calif.

### MOTOROLA, SEVERAL MODELS

When these come in dead, look first for one or more broken leads in the vibrator. Replace them, for they will break again if merely soldered to the vibrator prongs.

It is sometimes necessary to re-adjust the vibrators as the new wires sometimes change the frequency of vibration.

DONALD R. DAILEY,  
Purcellville, Va.

# Systematic Circuit Tests

By R. E. ALTOMARE\*

THE passing years since Marconi sent his first intelligible message across the English Channel, has seen radio progress from a crude method of communication to a highly developed technical science. In the first stages of development, many venturesome amateurs and experimenters built their own receivers from crystal sets to one- and two-tube affairs. These home builders serviced their own sets when trouble appeared, often with only a screw driver and a pair of pliers. These same men constituted the first professional servicemen. As receivers became more and more complex in design, radio servicing gradually passed from the "screw-driver mechanic" stage to a science requiring a specialized technique. The self-styled serviceman who failed to keep pace with advancements slowly began to fade out of the picture. Unfortunately, however, there are still many servicemen who have managed to get by with the barest of essentials.

Today, the war finds many of the experienced servicemen in the armed forces or performing associated duties in industry, and the field is left to many less capable men and newcomers of varied ability.

Whether we refer to the professional serviceman, who caters to repairs of broadcast receivers of all types; the student in a radio school, who is endeavoring to learn the rudiments of trouble shooting; or the maintenance radio men in any of the branches of the armed forces, the technique involved is essentially the same.

\*Capitol Radio Engineering Institute, Washington, D. C.

A radio set analyzer, of a type universally used some years ago. —Courtesy Weston Electrical Instrument Co.

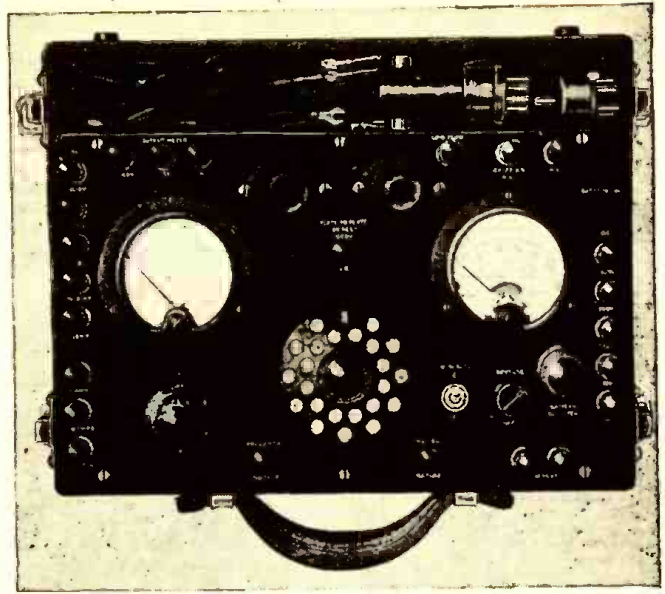

Diagnosing an ailing piece of electronic equipment, as well as localizing the fault and then rectifying it, is not a difficult task if one is familiar with the fundamentals of radio circuits and learns to practice a good technique, which develops with experience.

The most successful trouble-shooters are essentially good technical diagnosticians. These men most often deliver the goods quickly and efficiently. Yet it is amazing how many students, maintenance men, even servicemen of some standing, seem to think the way to locate trouble is to turn the defunct chassis upside down, prod around with a voltmeter or ohmmeter or bridge across suspected condensers with good ones. This hit or miss method avails one nothing and, as one officer-engineer tells his students, "the war might be over before you locate the trouble."

So it is advisable, nay, imperative, that one proceed in an orderly and logical manner.

## FOUR STEPS TO SERVICING

There are four distinct and logical steps in servicing electronic equipment. These are:

- General diagnosis or analysis.
- Localizing the defective stage.

- General diagnosis.
- Localizing the defective stage and
- Isolating the defective component.
- Replacement or repair of the defective part.

The general diagnosis is important as it may save much time. It includes noting the "effects" or type of trouble and we should try to deduce logically the probable cause of the effect. The few moments this takes are well spent. Ask brief questions of the operator of the equipment to determine the history of the complaint. Did the set stop operating suddenly? How long has this trouble been manifest, etc.? It also includes looking for surface defects such as: Do all the tubes light up (or get warm if they are metal tubes)? Are there any obviously broken connections, etc?

- Localizing the defective stage and
- Isolating the defective component.

The next steps should be to localize the defective stage and then isolate the defective part. For simplicity of presentation the two procedures will be discussed together. These steps are the most important in trouble-shooting.

All methods of analysis fall into one of the following, or may be a modification or (Continued on page 246)

Fig. 1.—The circuit of a free-point set checker. Fig. 2.—Critical points in a typical audio stage. Fig. 3.—Standard superheterodyne block diagram.

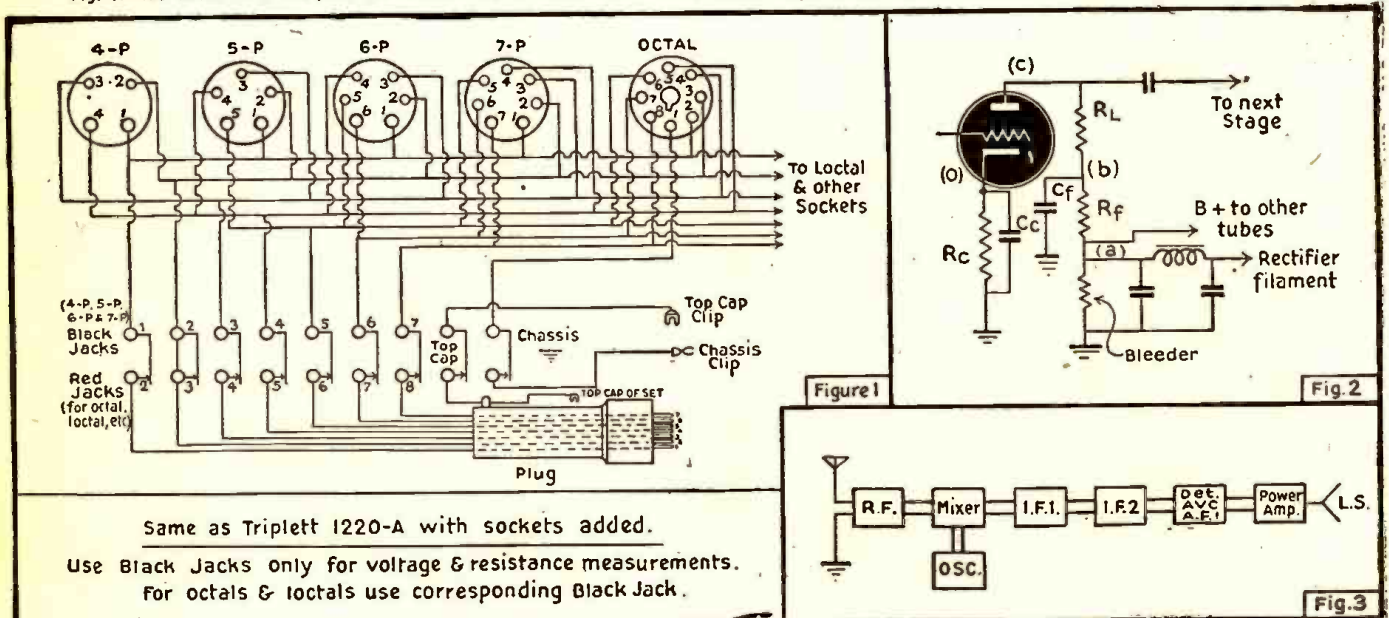

**MEISSNER  
RADIO PHONO RECORDER**

MODEL 9-1065

POWER SUPPLY...110-125 volts,  
50-60 cycles A.C.

POWER CONSUMPTION...  
110 Watts including motor  
INTERMEDIATE FREQUENCY.....456 Kc.  
ALIGN.....1400 Kc.  
PAD.....No adjustment necessary  
NEON VOLUME INDICATORS.....GE T-2  
DIAL LIGHT

Any 6-8 Volt type—Bayonet Base

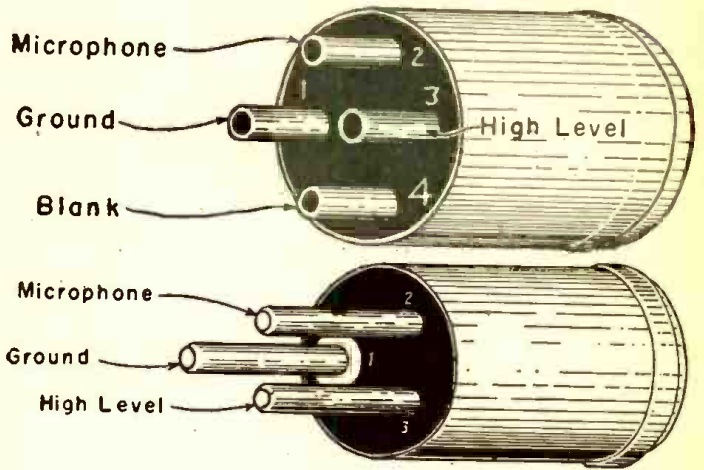

**OPERATION**

The chart shown at the bottom of the page is designed to give the user of the Meissner Radio-Recorder a quick insight of the functions of the various controls. For best results the notes and instructions following the chart should be read and followed, since the chart alone cannot contain all the information essential to the proper use of the equipment.

**SERVICE DATA**

**Cutting Arm Adjustments**

1. Place on the turntable an uncut record of the type that is to be used for recording.
2. Place stylus in the cutting head. Insert it as far as it will go, rotate it until the long flat on the shank of the stylus faces the stylus screw, then firmly tighten the screw.
3. Raise the cutter arm well up from its rest, swing it over the record and carefully lower it so that the stylus rests on the record near the center (which should not be revolving). Observe the position of the stylus screw in the slot

in the cutter arm. If the screw is approximately in the middle of the slot no adjustment of the cutter arm height is required, but if the stylus screw is close to either the top or the bottom of the slot the arm should be adjusted in the following manner:

(a) Lift the cutter arm into a vertical position. Underneath the arm will be found a machine screw on which the arm rests. The adjustment of this screw is preserved by a lock nut. Loosen the lock nut and rotate this screw until the stylus screw occupies the center position in the slot when the cutter arm is in the recording position, then tighten the lock nut and again check the position of the stylus screw to see that the adjustment has not been disturbed by tightening the lock nut.

(b) Cut a few blank grooves (volume control at zero) while watching the stylus screw to see that as the record revolves, the stylus screw does not approach either end of the slot. If this condition holds true, the height of the cutter arm is properly adjusted until a new stylus is used having a length a great deal different than the stylus used in

the original adjustment, or unless records of a new thickness are used that are sufficiently different from the original records to require readjustment of cutter arm height. NEVER ATTEMPT TO MAKE A RECORDING WITH MORE THAN ONE DISC ON THE TURN-TABLE.

If the normal position of the screw is too high, the entire weight of the cutting arm is placed on the stylus when the stylus screw hits the top of the slot. This heavy weight will cause the stylus to dig into the record base and ruin at least the record and in all probability the stylus as well.

**SPECIAL INPUTS**

In many cases it may be desirable to introduce external input to the amplifier other than that from the microphone. For either recording or Public Address work it may be desirable to feed in the output of (a) an external radio (b) FM Tuner (c) external phono pickup or other electronic devices. Such sources are considered high level inputs and the gain switch should be set accordingly.

Position of Selector Switch	Radio Only	Phono Playback	Record Mike	Record Radio	Public Address
Tuning	Radio Tuning	_____	_____	Radio Tuning	_____
Tone	_____ Tone Control & Line Switch _____				
Normal and Overload	_____	_____	Volume Level Indicators	Volume Level Indicators	_____
Volume (Left Hand)	_____ Volume Control for Left Hand Mike _____				
Volume (Right Hand)	Radio Volume Control	Phono Volume Control	Volume Control for Right Hand Mike	Radio Volume Control	Volume Control for Right Hand Mike
Mike (Left Hand)	Input for Mike, External Radio, or External Phono				
Mike (Right Hand)	_____	_____	Input for Mike Ext. Phono Ext. Radio	_____	Input for Mike Ext. Phono Ext. Radio
Gain	_____ Gain Control for using different types of Microphones _____				

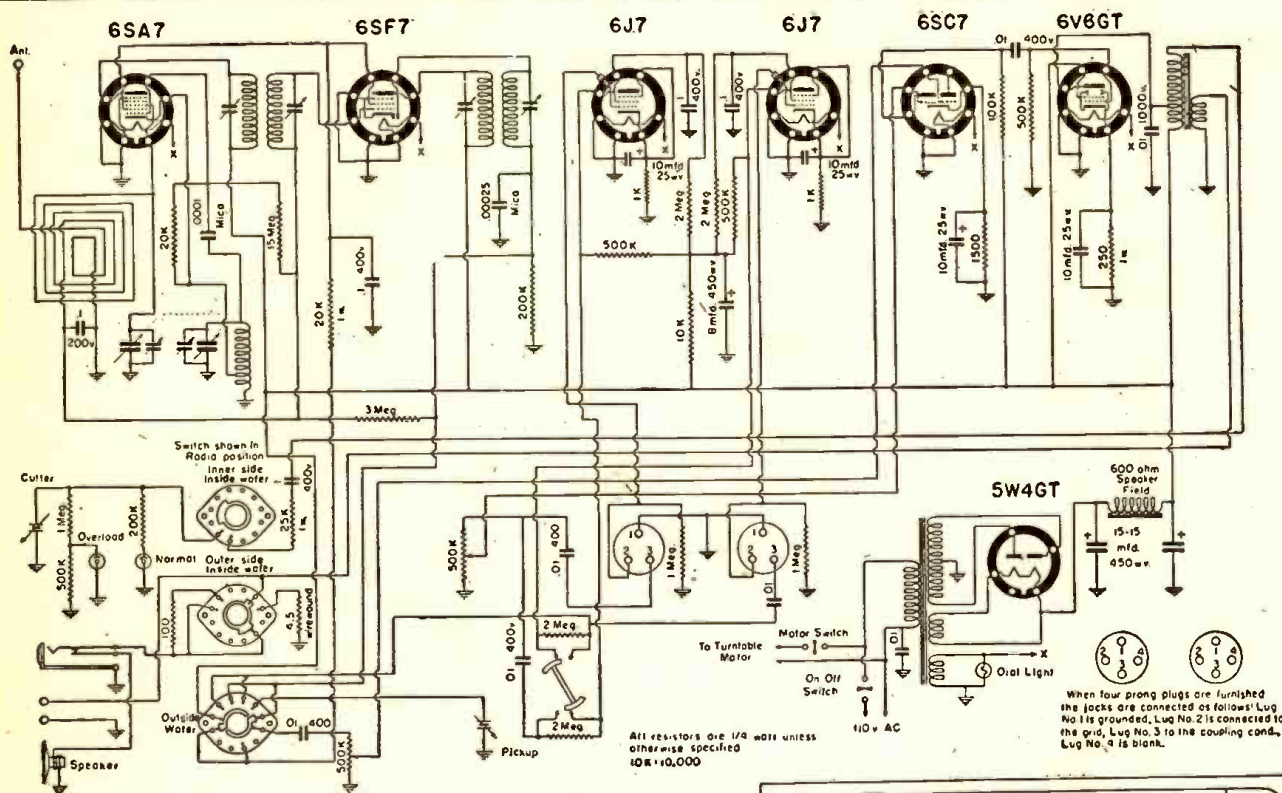

**POWER SUPPLY**

This Radio-Recorder is designed to operate from a 110-125 volt 50-60 cycle alternating current supply. Never attempt to operate it from other source of supply—serious damage to the equipment is almost sure to occur.

**ADJUSTMENT**

**Cutter Arm Height**

The cutter arm height is adjusted at the factory for a standard  $\frac{5}{8}$ " stylus. If recording blanks of the usual home recording type are used, the cutter arm height should not have to be changed. If recording blanks of unusual thickness are used, it will be necessary to re-adjust the cutter arm height. For instructions for performing this adjustment, refer to the section of this instruction sheet entitled SERVICE NOTES.

**Reproducing Needles**

In choosing the correct reproducing needles to use, it should be kept in mind that while most any good make of reproducing needle is satisfactory for reproducing commercial records, the same is not true with home recordings. The material used to make instantaneous recording blanks is necessarily softer than the material used in commercial records and is more easily damaged by a reproducing needle which is not properly made to fit the groove in the record. There are a number of good needles on the market made especially for reproducing instantaneous recordings.

All resistors are 1/4 watt unless otherwise specified  
10K = 10,000

When four prong plugs are furnished the jacks are connected as follows: Lug No. 1 is grounded, Lug No. 2 is connected to the grid, Lug No. 3 to the coupling cond., Lug No. 4 is blank.

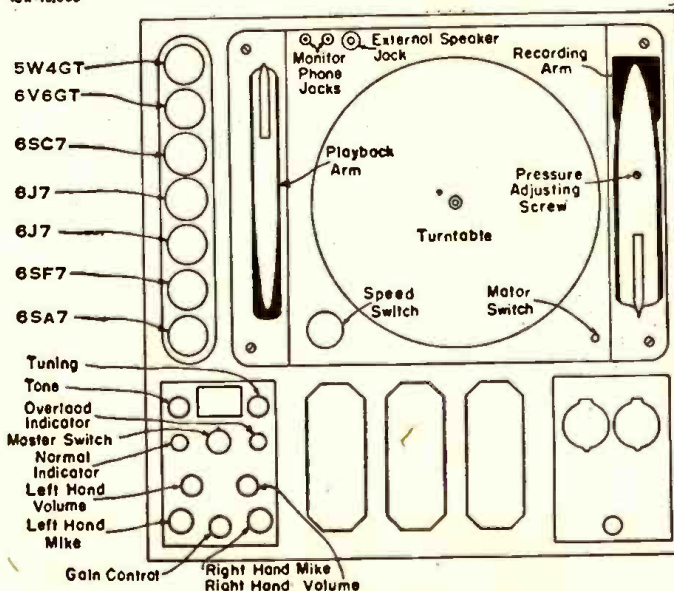

**VOLTAGE CHART**

Tubes	# 1 Pin	# 2 Pin	# 3 Pin	# 4 Pin	# 5 Pin	# 6 Pin	# 7 Pin	# 8 Pin
6SA7	—	—	260	80	—	—	6.3 AC	—
6SF7	—	—	—	80	—	260	6.3 AC	—
6J7	—	—	60 *	— †	.4	250	6.3 AC	.4
6J7	—	—	60 *	— †	.4	250	6.3 AC	.4
6SC7	—	125	—	—	125	1.7	6.3 AC	—
6V6 GT	—	—	230	260	—	—	6.3 AC	12.5
5W4GT	—	310	—	320 AC	—	320 AC	—	310

Note: Line voltage = 117 volts \* Measured on 1000 volt range. † Very low reading on 1000 volt range. Switch to be in RADIO position for all readings

# Hughes Balance Metal Detectors

By ERIC LESLIE

**M**ENTION of the Hughes Induction Balance in the October editorial has provoked considerable correspondence. A surprising number of persons—including a few electrical engineers—have never heard of the device, and ask for information as to its principle of operation, and how it may be constructed.

The Hughes Induction Balance is by no means new. It was used in the '80's, but belongs to that unfortunate class of instruments which were hampered by the crudity of the associated apparatus which could be used with them, and had been practically forgotten before the advent of modern devices which might have rendered them widely applicable.

In its simplest form, the Hughes Induction Balance consists of four coils, a pair of headphones and a buzzer or a microphone and some means of producing sound. See Fig. 1. A common set-up was to place a loud-ticking clock directly in front of the microphone.

Two of the coils are connected in series with each other and the buzzer or microphone. These may be considered the "transmitter" end of the circuit. Their function is to induce into the other "receiver" coils an alternating current. The two receiver coils are so connected that the current in one bucks that in the other, with the result that no signal is heard in the phones.

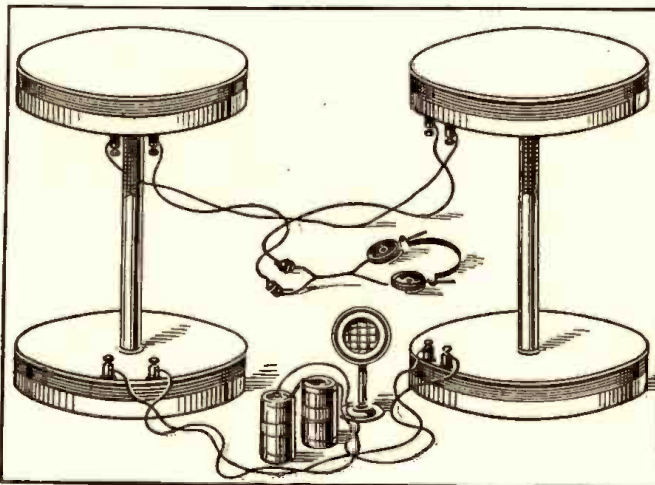
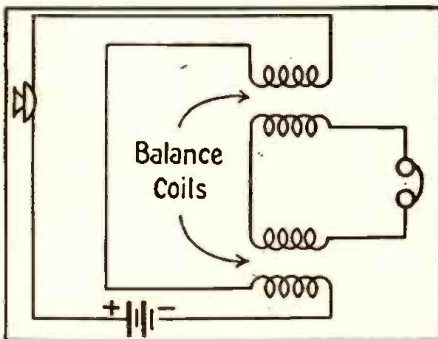

The coils are wound on rings or discs, which may then be slid up and down a cylinder or rod to obtain this balance. Fig. 2 makes this clear.

The four coils must be absolutely identical. They may be wound on cylindrical forms  $3\frac{1}{2}$  inches in diameter and 1 inch long. No. 32 or other available wire may be used for the windings. The favorite wire of the old physics experimenters was double-silk covered, but modern enamel-covered wire will be just as effective. Each coil should have about 300 turns. These may be wound in 60-turn layers, giving each layer a coat of coil dope and letting it get fairly stiff before winding on the next. Strips of thin glassine paper between layers will help to keep the end turns from slipping down. Leads about two feet long may be left to make connections with associated apparatus.

In the balance illustrated in Fig. 2, the coils are cemented to discs of wood, which are bored in the center to admit the sup-

porting rod. The lower discs should be large enough to offer a firm support to the apparatus, the upper ones just large enough to support the coils. The rods should be cemented firmly into the holes in the lower discs. Those in the upper two discs should be drilled carefully, to make a tight fit around the center rod, so that the disc can be slipped up and down to adjust the distance from the primary coils, but will remain securely in place if not touched. This is very important, as no metal clamping device can be used to keep these coils in place. Slight differences between the coils will make some adjustment necessary, but if they are properly wound, such adjustments should be very small, in the order of fractions of an inch.

Cardboard or thin fibre discs may be cemented to the top of the coils, to act as platforms.

The coils are hooked up as shown in Fig. 3. For the source of power, an audio oscillator or even a buzzer may be used. This can be coupled into the balance through a step-down transformer. A plate-to-line transformer would probably be the most suitable type readily available, but for experimental purposes an ordinary plate-to-voice-coil output transformer should be good enough.

Another low-impedance winding may be placed in the "receiving" circuit, to couple to the amplifier. A voice-coil-to-grid, or an ordinary output transformer hooked up

(Continued on page 248)

Various types of metal locators, some based on the Hughes Balance, have been devised and used. Though no detailed information on these Army mine locators is available, their general appearance would lead to the belief that they are heterodyne detectors.

Official Photo U. S. Army Air Forces

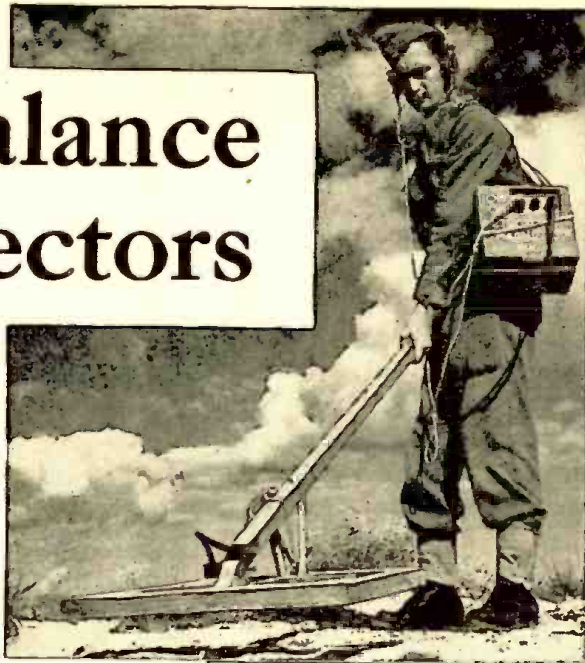

Signal Corps Photo

Fig. 1.—(top) Schematic of the Hughes Balance at the left.

Fig. 2. — Traditional form of the Hughes Balance. The microphone may be replaced by a buzzer, an A.C. transformer, or any other means of setting up an alternating current in the secondary windings. An amplifier input would be a great improvement over the phones, which were considered very good sound detectors when the Balance was widely used.

# OSCILLATING RADIOS

By JACK KING

**C**ERTAIN service troubles recur again and again. Regeneration and Oscillation being two such troubles. The remedies may vary, but fundamental principles can always be applied successfully to find the cause of unwanted regeneration in a circuit.

Fig. 1 shows a typical audio amplifier system. While others may differ from this one in some respects, the remedies applied

remove the howl you know that a new condenser really is needed.

When C7 opens up, the plate load becomes largely inductive. Since the inductive reactance increases with higher frequencies (audio band), the impedance of the plate load is very high at the high end of the band when C7 is open. The grid-plate capacity of the tube, however, has a reactance which decreases with frequency, so that it

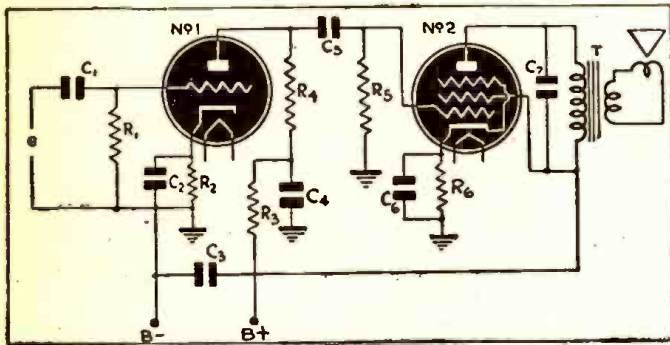

Fig. 1—Typical audio amplifier circuit of the resistance-coupled type. Transformer-coupled amplifiers are even more likely to oscillate, but the causes are the same in each type.

here will serve equally well in many more or less similar circuits. For example, an open in C7 will be responsible for a loud howl in many cases. The condenser can be tested simply by shunting it with another one of the same capacitance value. If the howl disappears a new capacitor is required, of course.

The capacity should be the same as the original—for this reason: If a larger value is used squealing which originates in some preceding stage and results in an audio note in the output stage may seem to be eliminated, due to the filtering action of the large condenser. Larger values of C will lower the response of the set, as C7 is a shunt across the plate load. If the original condenser has a value of .01 and a squeal is heard when it is replaced, but is cut down in intensity when a .05 mfd. unit is used, don't make the mistake of assuming you have found the trouble—you have simply cut down on the response of the set at high audio frequencies. If you find that replacing of C7 with a condenser equivalent in capacity to the original does

is much lower at the high end of the audio band and, accordingly, considerable feedback may take place through the grid-plate capacity. This leads to regeneration and then to oscillation as the circuit losses are overcome and the tube "spills over."

## COMMON IMPEDANCE COUPLING

Still another form of trouble can develop in a circuit of this kind. Let's assume that C3 opens up. The net result will be that the B supply has a high audio impedance between the B plus and the B minus terminals. This gives us a common coupling in a common impedance. That is, the plate circuit of the driver tube No. 1 and the plate circuit of the output tube No. 2 are connected through the common impedance of the power supply. Any variation in the current of the output tube will cause a drop across this impedance and hence variation in the current of the input tube No. 1. This is a common cause of "motor-boating" in radio receivers and audio amplifiers.

Let us visualize a signal voltage due to the output tube not only appearing across

the plate load of tube No. 2 but also, in part, across the B supply, across the terminals of C3. Now, this signal voltage will send a current through R3 and R4 and the tube marked No. 1. It will also cause a signal current to flow in R5 through C5 and the signal will be amplified and re-amplified in this way. This amounts to a "feedback loop." If C3 is not entirely open, the amplifier may "motorboat" or "putt-putt" instead of singing or squealing. This tendency to oscillate will be greater if R3, R4 and R5 are small, so far as passage of signal current from the B supply, due to audio voltage, is concerned. If R5 is small compared to R3 and R4 the effect will be minimized; but in most sets R5 is about twice R4. If the coupling condenser is large, the effect will be more pronounced, and if C4 opens up the feedback will be aggravated.

## DIRECT CAPACITY COUPLINGS

If you were building an amplifier of this type, you would try to keep the plate circuit wiring of No. 2 away from the grid circuit wiring of the same tube and away from the grid and plate wiring of tube No. 1. This would minimize feedback troubles. In some high gain circuits it is even necessary, if the two tubes are placed close together on the same chassis, to shield No. 1 so that there will be no capacitive coupling between the elements of tube No. 1 and No. 2.

Capacitive coupling may be found in other places in a radio receiver. For example, in Fig. 2, if the antenna of the set is brought near the 6C6 detector and there is an open condenser (marked C9 in the diagram) development of an R.F. voltage in the plate circuit will be possible and there may be coupling between this plate circuit and the antenna, so that energy is fed back from the detector to the R.F. input, thus forming a feedback loop and causing regeneration or oscillation. Small T.R.F. sets sometimes have this trouble. Moving the antenna near and then away from the detector will change the coupling and the intensity of the oscillation, hence such movement is one of the ways of checking on the condition.

Still another form of oscillation in a circuit of this kind may be due to coupling in a common high resistance chassis impedance. Current flowing between the lower terminal of L4 and C11 may flow through the same chassis path for a short distance with current flowing from the lower terminal of L2 to C2. In some sets re-routing the wire from the lower terminal of each coil directly to the associated tuning condenser rotor will aid in securing stability. In other sets the simple expedient of soldering a wire in place between opposite sides of the chassis will improve performance.

It may be found in some cases that the designer has purposely allowed a slight amount of feedback to exist for the purpose of increasing the selectivity and gain of the simple T.R.F. circuit. Common coupling between circuits is not the only form of feedback—coils in the R.F. and detector circuits may be coupled electromagnetically. This will cause feedback. The coils can sometimes be moved slightly to minimize coupling. In many of these sets the detector tube is unshielded but the R.F.

(Continued on page 240)

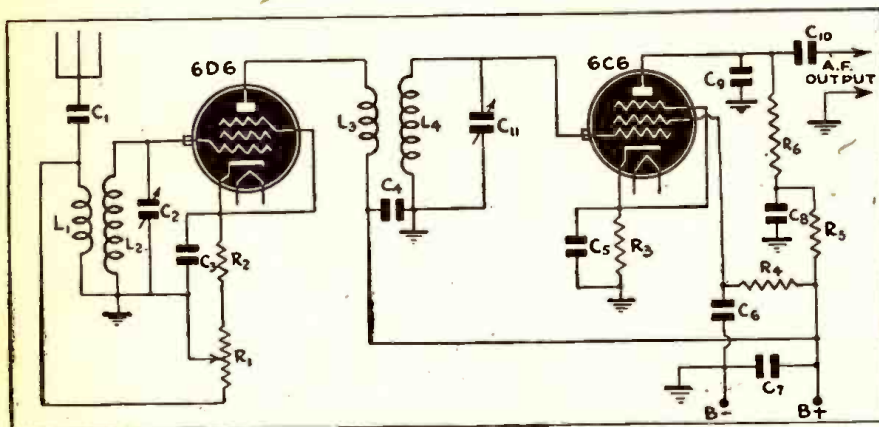

Fig. 2—One-stage R.F. and detector. Oscillations can originate at several points in such a circuit, the most common causes being feedback from the output to input circuit of the 6D6.

# Latest Radio Apparatus

## SENSITIVE RELAY

Struthers-Dunn, Inc.  
Philadelphia, Penna.

**A** NEW Struthers-Dunn relay, Type 79XAX, is designed for a variety of electronic circuit applications calling for a highly sensitive unit having snap-action contacts. Contact pressure of this relay remains constant despite slow variations in the coil current in which it is connected. Then, when the coil current reaches a certain point, the contacts operate with a positive snap action.



The relay operates on as little as 10 milliwatts in its coil circuit, and is recommended for dozens of highly sensitive vacuum tube applications, as well as in detecting overloads at low current levels. Its greatest field of usefulness lies in applications where current varies slowly between various limits, rather than quickly from 0 to rated value.—Radio-Craft

## D.C. TIMING MOTOR

Haydon Manufacturing Co.  
Forestville, Conn.

**A** NEW type of D.C. motor for timing applications on D.C. current is announced. The new unit will be marketed under the trade name of: Haydon D.C. Timing Motor.

This is a normally running 6 volt motor with resistance wire calibrated at the factory for 12 volts, 24 volts, and other voltage applications. It is available with all the various output shaft speeds which the company now has in its A.C. line of timing



motors, these speeds secured through sealed-in lubricated gear trains. Speeds available will be from 900 R.P.M. down to one revolution per month.

Extremely consistent speed is obtained by the governor effect of an electrical eddy current drag built into the motor. A unique feature is the fact that there is no arcing at high altitude operation and brush life is unusually long. The motor can be purchased with special lubricant for operation at extremely low temperatures.

This motor is entirely new in design, reversible, weighs approximately 6 ounces and operates on a current input of approximately 100 ma., no load. The motor, including gear reduction, measures only 2 7/16" high by 2 1/8" wide by 1 3/8" deep.—Radio Craft

## LOW-RESISTANCE TEST SETS

Shallcross Mfg. Co.  
Collingdale, Penna.

**T**WO new Shallcross Low-Resistance Test sets, Type 645 (Army range) and Type 653 (Navy range) include all popular features of previous models with the added convenience of complete portability and greater freedom, ease, and speed of operation.

The Test unit containing the meter, batteries, switches, control, etc., is supported comfortably and conveniently in front of the operator by means of adjustable shoulder straps. Bond or contact resistance measurements as low as .0001 ohms can then be made, simply by attaching the fixed clamp to one side of the bonded surface, then touching the hardened points of the Pistol Grip Exploring probe on the other side.

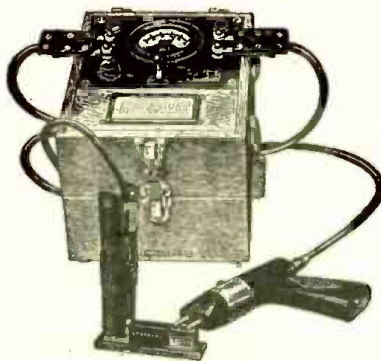

Both hands are free at all times to adjust and operate the instrument. The weight of the Pistol Grip Exploring Probe is reduced to a minimum by incorporating the meters, batteries, etc., in the cabinet suspended from the operator's shoulders.

In addition to their widespread use in testing aircraft bonding, these Shallcross Sets are unexcelled for testing railroad bonds, radio equipment, contact resistance of relays, circuit breakers, switches, and various others. They make bar-to-bar resistance measurements on commutators as simple as making a voltmeter reading.

Type 645 (Army range) is 0.005 and 0.5 full scale. Type 653 (Navy range) is 0.003 and 0.3 ohms full scale.—Radio-Craft

## AIR INDUCTORS

Barker & Williamson  
Upper Darby, Penna.

**S**TANDARD B. & W. heavy duty coils meet many electronic heating applications up to 1 KW. Of the well-known B. & W. "Air Wound" design (no solid winding form) these coils are light in weight, adaptable to numerous mounting arrangements, are exceptionally sturdy, and have low dielectric loss. Equally important, they are wound to uniform pitch, offer utmost design adaptability, and lend themselves readily to mechanical and electrical revisions in circuits that must be adjusted, or which are still in the experimental stage. Many special coils are also being produced regularly for electronic heating uses.—Radio-Craft

## FIBERGLAS SLEEVING

Bentley, Harris Mfg. Co.  
Conshohocken, Penna.

**I**N appearance like an ordinary silk sleeving, this product is non-fraying, flexible, fireproof and heat and water resistant.

The non-fraying feature is claimed as one of the greatest advantages, especially where vibration is encountered. The former practice was to stiffen the ends of the sleeves. This dipping process is obviated with BH Fiberglas. Another advantage of this type of sleeving is its high dielectric strength. Flexibility is equal to that of older types of sleeving, in fact the uninformed observer unhesitatingly states that the material is some kind of silk.—Radio-Craft

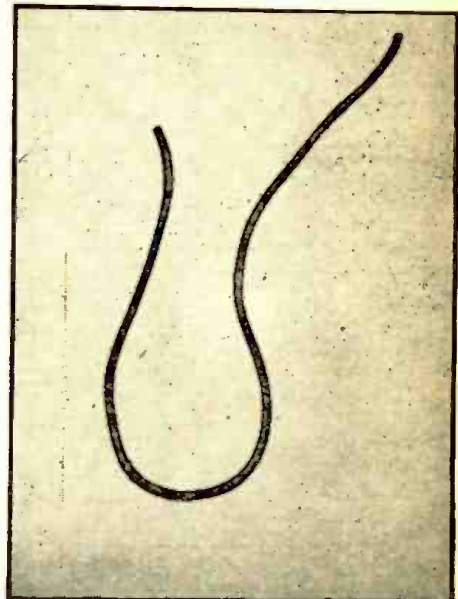

The electric instrument industry has increased its production 4,000 per cent in the past three years, according to a report made to the convention of the National Electrical Manufacturers' Association. The present output of electric instruments is at the rate of 28,000,000 per year, as against 700,000 in 1940, said H. P. Sparkes, president of the association.



# WE ASKED 817 MEN TO NAME THE *Best* RADIO TRAINING BOOK THEY KNOW!

## UNUSUAL SURVEY REVEALS WHAT RADIO MEN THINK OF RADIO BOOKS

Men! Here's your chance to get started on the right track in your study of Radio-Electronics—without guesswork and without investing a lot of money!

We contacted a mixed group of 817 radio men composed of Radio instructors, Service-men, Radio men in the U.S. Military and Naval Forces, in radio manufacturing plants, etc.—asked them to tell us without prejudice or favor just what they think of the various

books and courses offered to beginners for the study of Radio-Electronic fundamentals. WE'VE MADE A DISCOVERY! Nine out of ten of these men—728 to be exact—wrote back that Ghirardi's RADIO PHYSICS COURSE is their choice—the most understandable, thorough, and inexpensive Radio-Electronic book there is—far better than any other book or course they have ever seen!

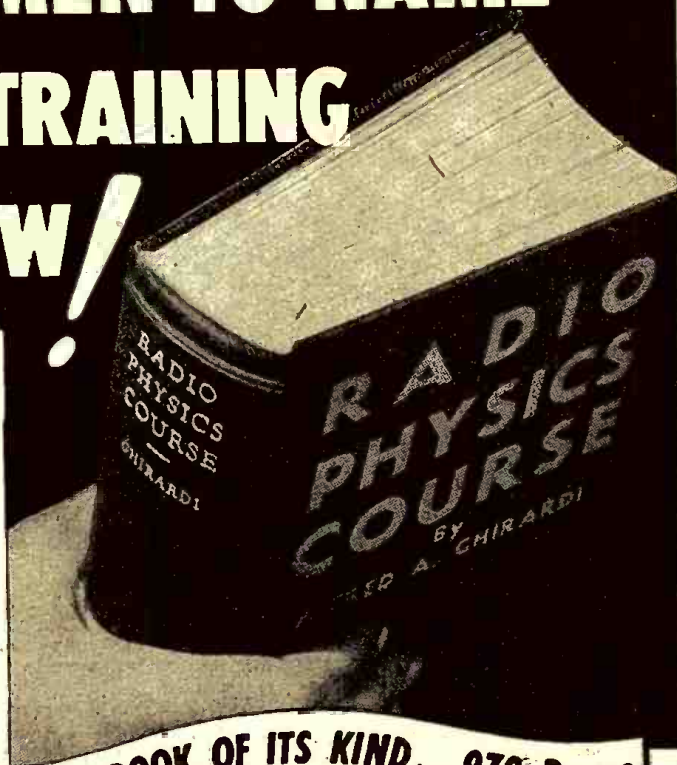

## Your Money Back

THE ONLY BOOK OF ITS KIND... 972 Pages

**YOUR MONEY BACK!** . . . If Ghirardi's big 972-Page RADIO PHYSICS COURSE doesn't teach you the fundamentals of Radio-Electronics and Electricity **FASTER, EASIER,** and at **LESS COST** than any other Radio book!

Are you one of the thousands of men who'd like to learn Radio-Electronics but can't seem to make up their minds about just what to do or how to get started for a profitable, interesting career? If so, cheer up, for Ghirardi's famous RADIO PHYSICS COURSE—the simplified, down-to-earth book from which thousands just like you have learned Radio—is exactly what you need to teach yourself the easiest way, right from the ground up, at home in spare time—and help you check your own progress every step of the way. They say it's the easiest, quickest, and most inexpensive method of learning the required Radio-Electronic essentials. That's why it is used and recommended as the text for U. S. Army Signal Corps training courses in Radio fundamentals.

### NO OTHER RADIO COURSE LIKE IT

You've never seen any Radio Book like Ghirardi's RADIO PHYSICS COURSE—because there isn't any other like it anywhere, at any price. Starting right at the beginning—over 300 pages devoted to the all-essential Electrical fundamentals alone—Ghirardi teaches you EVERY important branch of this fascinating subject. He takes nothing for granted, but illustrates and explains every last detail step-by-step and so carefully that it is crystal clear before you go on to the next. That's the big difference between RADIO PHYSICS COURSE and other radio courses which take too much for granted. That's why both civilian and military Radio Instructors everywhere report that their students learn Radio far more quickly and easily from this than from any other Radio text—

it's practically a self-teacher. That's why Ghirardi's famous RADIO PHYSICS COURSE is used by more U. S. Army Signal Corps, Navy, civilian school and college radio training courses, and for more home study uses than any other basic Radio book published!

### COURSE OF 36 COURSES IN ONE BIG BOOK

Because Ghirardi's RADIO PHYSICS COURSE is so comprehensive, and so thorough in its explanations, it is a large volume—larger by far than any other book of its type. Actually, it gives you, the scope of 36 different courses in one—packed into nearly 1,000 pages, made easily understandable by more than 500 specially prepared illustrations, and containing 856 self-testing review questions. All this costs you only \$5.

### 5 Days to See for Yourself—AT OUR RISK

Got started at once by mailing the coupon below—now! Our 5-day MONEY-BACK Trial Offer enables you to examine this great book without assuming any risk whatever. Prepare now for a fascinating Radio-Electronic Future—in the Signal Corps, in the Navy, in Aviation, Broadcasting, Electronics, Television, Manufacturing or any of the many other branches! Send the coupon below—**AT ONCE!**

### Other GHIRARDI Books to Help You



★ **MODERN RADIO SERVICING** ... A complete, 1300-page, 1-volume home-study Course in Radio Servicing. Explains to the last "r" every phase of the entire art of Trouble-shooting and Repairing radio equipment by the most advanced methods. 708 illustrations. Price \$5.



### ★ RADIO TROUBLE-SHOOTER'S HANDBOOK

A big, new 744-page Revised Edition of Radio's most popular factual Data Handbook for repair work. Now contains 75 big sections of invaluable tabulated and charted troubleshooting and repair data for over 4,800 receiver models. Saves hours of trouble-shooting and repair time. Pays for itself the first time you use it! (8 1/2" x 11" size). Price \$5.

**SAVE MONEY!**

Get both of the above servicing books at a real savings! Over 2,000 pages of vital knowledge in MODERN RADIO SERVICING and TROUBLESHOOTER'S HANDBOOK—a \$10.00 value—for only \$9.50 if purchased together. Use coupon below.

## THE 3 GREATEST VALUES IN MODERN RADIO TRAINING!

Sold at 1/10th the price you might expect to pay for such complete instruction.

RADIO & TECHNICAL DIVISION OF MURRAY HILL BOOKS INC., Dept. RC-14  
232 Madison Ave., New York 16, N. Y.

Rush me the books checked below.  Money enclosed.  Send C.O.D. (In U.S. only). If I am not fully satisfied, I may return them at the end of 5 days and receive my money back.

- Ghirardi's RADIO PHYSICS COURSE \$5.00. (\$5.50 foreign)
- Revised RADIO TROUBLESHOOTER'S HANDBOOK \$5.00. (\$5.50 foreign)
- MODERN RADIO SERVICING \$5.00. (\$5.50 foreign)
- MONEY-SAVING OFFER—THE HANDBOOK and MODERN RADIO SERVICING at special price of only \$9.50 for the two. (\$10.50 foreign)
- Rush free literature on all of above.

Name .....  
Address .....  
City ..... State .....  
Dist. Deliv. No. ....

**MONEY-BACK GUARANTEE!**  
YOU BE THE JUDGE



**ALFRED A. GHIRARDI**  
World-famous Radio Authority



**MAIL NOW** ▶

# The Listening Post

Edited By **ELMER R. FULLER**

**W**E wish to thank all of our readers for the cooperation which they have shown in sending in reports on the short wave stations they hear. This is the only way we have of checking the frequencies and schedules of many of these stations under present world conditions. Keep up the good work, and we will try to keep the station lists revised.

Reports are wanted on the reception of the Chinese radio station XGOY, located at Chungking, and operating on a frequency of 6.130 megacycles. Verifications may be received from Ying Ong; 1001 E. Roosevelt Street; Phoenix, Arizona.

Attention is called to the frequency test conducted by the station in Beltsville, Maryland, on 10.000 megacycles. It may be heard every hour, on the hour, with signals and explanations. Also, the U. S. Bureau of Standards maintains a station on 5.000 megacycles, which gives the standard of frequency, time, and musical pitch.

Verifications of programs of OPL, Leopoldville, Belgian Congo, may be obtained from the Belgian Broadcasting Service; 247 Park Avenue, New York City. Cards are black on white background, and show a map of the world and distances from Leopoldville to various places in the United States. This information was supplied by Robert Grimm of Macon, Missouri.

A newcomer to the dials is "Radio Inconnu" on 9.755 megacycles, and is being

heard Sundays from 3 to 3:11 pm. They sign on and off with chimes or bells, and the program consists of a man and a girl talking at the same time, in French, and as if they were having a quarrel.

"Praheva" is a new one heard on 9.870, and is also on Sundays from 5 to 5:07-pm. The program opens with a train whistle and closes with three whistles. A man is heard speaking in an unidentified language. The signals so far have been reported as very weak.

Heard on Fridays, at 7 to 7:30 pm, is another newcomer, Paramaribo, Dutch Guiana. The frequency used is 5.75 megacycles. Chimes followed by the Portuguese National Anthem, close the program of a new station in the Azores. The station, located at Ponta Del Gada, uses a frequency of 4.020. The time is 6 to 8 pm, daily.

Station Debunk is now being heard from 8:30 to 9 pm, on 7.180 megacycles, according to a bulletin just issued by the Federal Communications Commission. This publication also gives SBO, on 6.065 megacycles, and SBU, on 9.535 megacycles, at Motala, Sweden. The studios are in Stockholm, and the programs are beamed to Europe at 5:15 to 5:50 pm; and to us at 9 to 10 pm.

All schedules of the Portuguese stations are one hour later due to the change back to standard time in that country.

Reports for the past month were received from the following: Joseph R. Hell-

mer, Pennsylvania; National Broadcasting Station, Guatemala; Office of War Information, New York City; James F. Morgan, Indiana; Royal M. Gibson, Georgia; R. L. Morris, Virginia; Robert S. Duggan, Jr., Georgia; Robert Skutt, New York; William C. Duggan, Jr., New York; Burnell Thrasher, Missouri; J. B. Yates, New York; Solomon Smith, Newfoundland; Ying Ong, Arizona; Gilbert L. Harris, Massachusetts; Kenneth Noyes, California; Albert Simanas, Pennsylvania; and Robert A. Grimm, Missouri.

The following is a program schedule of XGOY, Chungking, China. They use a frequency of 6.130 megacycles. Broadcast to East Asia and the South Seas:

7:35 am	News in Spanish
7:45 am	News in Annamese
8:00 am	News in Cantonese
8:10 am	News in French
8:20 am	News in Japanese
8:30 am	News in Burmese
8:45 am	News in Dutch
9:00 am	News-Talk in Chinese
9:10 am	Music
9:15 am	News in Siamese
9:30 am	News in Malayan
9:40 am	Interval
9:45 am	News in Cantonese
10:00 am	World news in English
10:15 am	Music
10:20 am	Talk in English
11:00 am	Chinese news in English
11:15 am	Talk in English
11:30 am	Sign Off

*All schedules below are Eastern War Time.*

Mc.	Call	Location and Schedule	Mc.	Call	Location and Schedule	Mc.	Call	Location and Schedule
3.352	ZFA3	HAMILTON, BERMUDA; Mondays, Wednesday, and Fridays, 8 to 8:45 pm or later.	6.040	WRUW	BOSTON, MASSACHUSETTS; European beam, 2:15 to 4 am; Central American beam, 7:30 pm to 2 am.	6.165	HIBM	PORT AU PRINCE, HAITI; 7 to 10 pm.
4.020	—	PONTA DEL GADA, AZORES; 6 to 8:01 pm.	6.04	COBF	HAVANA, CUBA; not heard recently	6.170	WCBX	NEW YORK CITY; European beam, 11:45 pm to 3 am.
4.107	HCJB	QUITO, ECUADOR; 7:45 to 10 am; 8 to 10 pm; daily except Mondays; Sundays, 9 am to 8 pm.	6.05	GSA	LONDON, ENGLAND; Near East Africa and Gibraltar beam, about noon.	6.180	HJCX	BOGOTA, COLOMBIA; 7 pm to 12:15 am.
4.70	ZQI	KINGSTON, JAMAICA; Sunday, 6:15 to 6:55 pm; daily, 6:15 to 7:15 pm.	6.060	WCDA	NEW YORK CITY; 7:30 pm to 2 am.	6.190	DXG	BERLIN, GERMANY.
4.75	YVIRY	MARACAIBO, VENEZUELA.	6.065	SBO	MOTALA, SWEDEN; European beam, 5:15 to 5:50 pm; North American beam, 9 to 10 pm.	6.190	WGEO	SCHENECTADY, NEW YORK; 12:15 to 3:15 am; European beam.
4.76	YV4RO	VALENCIA, VENEZUELA.	6.070	CFRX	TORONTO, CANADA; Sundays, 9 am to 12 midnight; Monday to Friday, 7:30 am to 12:05 am; Saturday, 7:30 to 12:45 am.	6.200	ZYC7	RIO DE JANEIRO; never heard, as yet.
4.765	HJFB	MANIZALES, COLOMBIA.	6.080	WLWK	CINCINNATI, Ohio; European beam, 12:15 to 4:30 am; West South American beam, 8:30 pm to midnight.	6.20	GRN	LONDON, ENGLAND; 8:15 pm to 12:45 am.
4.77	YVIRY	CORO, VENEZUELA.	6.090	CBFW	VERCHERES, CANADA; daily, 7:30 to 11:30 pm (in French).	6.2	YV5RN	CARACAS, VENEZUELA; early evenings.
4.78	YV3RN	BARQUISIMETO, VENEZUELA.	6.09	ZNS2	NASSAU, BAHAMAS; Sundays, off at 10:05 pm.	6.220	—	"GUSTAV SIEGFRIED EINS"; 7:50 to 8 pm.
4.79	YV6RU	BOLIVAR, VENEZUELA; evenings.	6.095	OAX4H	LIMA, PERU.	6.243	HIIN	CIUDAD TRUJILLO, DOMINICAN REPUBLIC; evenings.
4.82	XEJG	GUADALAJARA, MEXICO; evenings.	6.100	COCO	HAVANA, CUBA; evenings.	6.280	HIIZ	CIUDAD TRUJILLO, DOMINICAN REPUBLIC.
4.92	YV5RN	CARACAS, VENEZUELA; evening transmissions.	6.110	GSL	LONDON, ENGLAND; North American beam, 6:45 pm to 12:45 am.	6.345	HER4	BERNE, SWITZERLAND; 9:30 to 11 pm daily except Saturday.
4.955	HJOO	BOGOTA, COLOMBIA; evenings.	6.120	WRCA	NEW YORK CITY; European beam, 12:15 to 2:45 am.	6.370	—	LISBON, PORTUGAL; home service, 4 to 8 pm.
5.620	OAX2A	TRUJILLO, PERU; heard Sundays 7:30 to 8 pm.	6.120	WKTS	NEW YORK CITY; European beam, 3 to 5 am; 8 pm to midnight.	6.370	WKTM	NEW YORK CITY; European beam, 6 pm to 5 am.
5.75	—	PARAMARIBO, DUTCH GUIANA; Fridays, 7 to 7:30 pm.	6.120	—	BERLIN, GERMANY; North American beam, variable times.	6.405	TGQA	QUEZALTENANGO, GUATEMALA; 9 pm to 2 am.
5.875	HRN	TEGUCIGALPA, HONDURAS; 7 pm to midnight; Sundays, off at 10:45 pm.	6.120	LRXI	BUENOS AIRES, ARGENTINA; "Radio El Mundo"; 9 to 12 pm.	6.47	COHI	SANTA CLARA, CUBA; afternoons and evenings.
5.875	TIGPH	SAN JOSE, COSTA RICA; not heard recently.	6.130	XGOY	CHUNGKING, CHINA; East Asia and South Seas; 7:35 to 9:40 am; North American beam, 9:45 to 11:30 am.	6.480	TGWB	GUATEMALA CITY, GUATEMALA; 7 am to 8:10 pm daily except Sunday.
5.935	PJCI	CURACAO, NETHERLANDS WEST INDIES; 7:45 to 10:38 pm.	6.130	COCD	HAVANA, CUBA; 7 pm to midnight.	6.715	ZLT7	WELLINGTON, NEW ZEALAND; daily at 5:30 or 6 am.
5.980	VONH	ST. JOHNS, NEWFOUNDLAND; Sundays 8:30 to 10:30 am; 1:30 to 6 pm; other days, 6:30 to 10:30 am; 2:30 to 7:30 pm.	6.130	CHNX	HALIFAX, NOVA SCOTIA; Sundays, 8 am to 6:55 pm; Monday to Thursday, 6:45 am to 10:15 pm; Friday, and Saturday, 6:45 to 11 am.	7.000	WGEA	SCHENECTADY, N. Y.; Brazilian beam, 8:30 to 11:30 pm.
5.985	WKRX	NEW YORK CITY; European beam, 10 to 11:15 pm; 12:30 to 2 am.	6.140	WBOS	BOSTON, MASS.; European beam, 3:45 to 5:45 am.	7.014	CMZI	HAVANA, CUBA; 11 pm to 12:10 am.
6.000	HH2S	PORT AU PRINCE, HAITI; 7:35 pm Saturdays.	6.140	DXX	BERLIN, GERMANY; 7 to 8 pm.	7.085	GRS	LONDON ENGLAND; Near East, Africa, and Gibraltar beam, about noon.
6.000	ZFY	GEORGETOWN, BRITISH GUIANA; 3:15 to 8:20 pm.	6.150	CJRO	WINNIPEG, CANADA; 6 to 11 pm.	7.12	GRM	LONDON, ENGLAND; 8:15 pm to 4 am.
6.005	CFCX	MONTREAL, CANADA; Sunday, 7:30 am to 12 midnight; Monday to Saturday, 6:45 am to 12 midnight.	6.150	GRW	LONDON, ENGLAND; Near East, Africa, and Gibraltar beam, about noon.	7.15	GRT	LONDON, ENGLAND; 10:45 pm to midnight.
6.010	CJCX	SYDNEY, NOVA SCOTIA; Sunday to Friday, 7 to 11 am; Saturday, 5:45 to 11 am; Sunday, 8 to 11 am.	6.160	CBRX	VANCOUVER, CANADA; 10:30 am to 2:30 am.	7.180	—	"STATION DEBUNK"; 8:30 to 9 pm.
6.020	ZFY	GEORGETOWN, BRITISH GUIANA; evenings.				7.18	CMZI	HAVANA, CUBA; daytimes.
6.02	—	"GUSTAV SIEGFRIED EINS"; not heard recently.				7.230	KWID	SAN FRANCISCO, CALIF.; Oriental beam, 6:30 am to 12:45 pm.
6.030	CEVP	CALGARY, CANADA; Sunday, 10 am to 1:30 am; Monday, to Saturday, 8:30 am to 2 am.				7.230	—	ROME, ITALY; off since September 8th, 1943.
6.03	DXP	BERLIN, GERMANY; North American beam, evenings to 1:30 am.				7.24	DXJ	BERLIN, GERMANY; 11 to 11:45 am.

(Continued on page 244)

# SPRAGUE TRADING POST



## A FREE Buy-Exchange-Sell Service for Radio Men

**WILL TRADE**—Radio & Television Institute three book course complete for Superior tube checker #1240 or what have you? Books on 5-day approval. George J. Smith, 132 So. 7th St., Steubenville, Ohio.

**WANTED**—Used tube tester and condenser and resistor tester, also 3 50L6GT, 3 80, and 1 6B7 tubes. Describe fully. Warren Demarest, Jr., 2446 Galvy, Baton Rouge, La.

**WANTED**—One Ecophone EC-1 or National SW-3. Must be in fair condition. Cash. S/Sgt. John T. Craig, Hq. Btry. 447, AAA, AW, BN., Fort Fisher, N. C.

**FOR SALE** — Used National NC100XS, \$125; Used RCA 809 tube, \$2.25; RCA 76, \$1; new Eimac 150T, \$25; new B & W 40JVL jr. coil, \$1; used GE 2 mfd. 1500 v. cond., \$3.50; used Thordarson class B mod. trans. input and output for 809's etc., \$7.50; RCA photophone 5' high metal relay rack with amateur and W.E. notchings, compl. with all new Bud masonite panels, never used, \$20, Fred Craven, 2215 So. 7th St., Philadelphia 48, Pa.

**WANTED**—Late or early model McMurdo Silver Masterpiece Radio model VI at reasonable price. Describe fully. Paul Capito, 637 W. 21 St., Erie, Penna.

**FOR SALE** on behalf of staff Sgt. in signal corps overseas: 150 different radio tubes and various other items of service stock incl. condensers, etc. Write for details. John Smirga, 1465 Byron St., Chicago 13, Ill.

**WILL TRADE** — 50L6GT's; 35Z6GT's; 35Z3's; 117Z6GT's; 70L7's; 12's; ham power trans.; Mac bug; ham filters; Supreme oscilloscope and other radio parts for S & W K-22 and/or Marlin lever action .22 rifle in good condition. Eddie, Box 2292, Orlando, Florida.

**TRADE OR SELL**—Teleplex electric code machine with speed control, headphones and several rolls practice messages. \$29.50 cash or will trade for new small midget radios. Also Philco non-refrigerated window air conditioner, \$39.50. Miller Electric Service, Ellenville, N. Y.

**FOR SALE**—One #1175A Triplett all-purpose, all-wave tester incl. #1151A all-wave signal generator and #1125B V-O-M or multimeter. Walter Benkwitt, 441 Willis Ave., Bronx, New York, N. Y.

**FOR SALE OR TRADE**—Precision #500 tube checker, good condition, with charts and factory data on modernization. Want condenser analyzer, Hickok 47X or similar, also late comb. tube checker and V-O-M. Paul J. McCray, 413 South Wayne St., Arlington, Va.

**TUBES FOR SALE**—About 100 new tubes, all saleable types. Some 12SA7, 50L6, 35Z5, and 80. Want to sell because of illness. Will sell only entire stock. Write for list if interested. Even Radio Co., 1538 Central Ave., Dubuque, Iowa.

**WANTED**—Rider's manuals Vols. 7, 11, 12, and 13. Have an extra Vol. 8 for sale. E. E. Trumpfeller, 71 North St., Houlton, Me.

**WANTED FOR CASH**—Copy of circuit and chart for #220 Simpson tube checker. Also want late model signal generator, set of Rider's manuals, resistance line cords, tubes, or what have you? French, 338 10th St., N. E. Washington 4, D. C.

**MANUALS FOR SALE**—New set of Rider's Nos. 1, 5, 6, 7, 8, 9, 10, 11, and 12 in original cartons. Price \$75. Northern Distributing Co., Britt, Iowa.

**FOR SALE**—One G.H.Q. miniature gas engine in new condition—not even completely assembled. \$18 complete. Ewell F. Nuckols, Rt. #2, Box 314, Richmond, Va.

**FOR SALE**—One large Weston meter, 4 1/4" diam., perfect condition, approx. 0-2 ma. Taken out of obsolete tube checker. Also have Electro-Voice #100 double-button carbon mike; and one HY615 and one 955 acorn tube. Want to buy for cash VR-150-30, also any 12, 35, 50 or 110 volt tubes, and a multimeter. The Chapin Studio, Chatham, Mass.

**TUBES FOR SALE**—Have several each of 35Z5, 1V 1H5, 50L6, 12SQ7, 1Q5, 6K7, 37, 25Z5, 6A8G, 34, 42, 47, 24A, 38, 235, 6C5, 3Q5. Must sell quickly—or will trade for tube tester or good V-O-M. Write for details. Pvt. Marvin H. Culp, 2nd Air Force, 420 Sig. Co. AVN, Colorado Springs, Colo.

**WANTED**—Signal generator and other test eqpt. wanted by service man just starting in business. Valbert French, Hico, West Va.

**FOR SALE**—Jewell #199 analyzer altered at factory to handle screen grid tubes. Best offer takes it. S. Q. Hull, 621 Hawthorne Ave., Kittanning, Pa.

**WILL TRADE**—Have one Thordarson T-74C29 filter choke; one 807 RCA tube; one 7V6 ditto; 2 7C7 Sylvania tubes; 1 7C5 ditto; and one 7C6 G-E tube. All brand new. Will trade for 0-1 milliammeter and one 50 ma. copper oxide rectifier for meter. Manassas Radio & Electric Repair Co., P. O. Box 298, Manassas, Va.

**FOR SALE**—1905 Ford automobile. Want to buy home radio sets. State condition and cash prices. Murray E. Main, Delaware, Ohio.

**WILL TRADE OR SELL** old copies QST, Radio, Radio Today, Radiocraft, Short Wave, Short Wave Craft, Radio & Television, Radio News, Radio Retailing, Service, etc. What have you—what do you want? Major Fred Kline, Kent, Ohio.

**FOR SALE OR TRADE**—New Philco 044 audio signal generator in original factory carton. \$19 cash—or want a Good record player or turntable & pickup. Wilbur Flaherty, 860 So. 17th St., Fort Dodge, Iowa.

**TUBES WANTED**—Am badly in need of following tubes: 50L6; 35L6; 12SA7; 12SQ7; 12SK7; 12K7; 12Q7; 35Z5; 24A; 117Z6; 1A5GT; 1A7GT; 1H5GT; 1N6GT. Will pay cash. Royce Saxton's Radio Shop, Route 1, Pontiac, Ill.

**WANTED**—RCA junior vohthomyst and Solar condenser tester. James Segadi, 2323 Grayling, Hamtramck 12, Mich.

**WANT TO BORROW** operating instructions and wiring diagram for Radiotelec Laboratory's tube tester. Will photo copy these and guarantee safe return. Deposit will be given. F. C. Brown, Island Radio Shop, Put-in-Bay, Ohio.

**WANTED**—Coil winder: 1S4; 1S5; 1T4, etc., or what have you? Edwin Bohr, Route 5, N. Chattanooga, Tenn.

**WANTED FOR CASH**—Audax microphone phone pickup, preferably D2E or D31E. Perfect condition. John D. Snyder, 533 Park Ave., Omaha 5, Nebr.

**WANTED FOR CASH**—Complete late test panel or Hickcock tube tester, RCA junior vohthomyst and CE Solar condenser tester. Joseph Ross, 11526 Dexter Ave., Detroit, Mich.

**URGENTLY NEEDED**—Any one of following Hallicrafters communications receivers: SX-24; SX-25; SX-28; SX-32. Cash. Also want Hallicrafters model S-51 speech amplifier or any hi-fidelity amplifier utilizing PP-45's or PP-2A3 tubes. S/Sgt. Donald H. Taylor, 130th Signal Radio Intel. Co., Army Post Office #958, c/o Postmaster, San Francisco, Cal.

**FOR SALE**—Never used: 1 fila. trans., 2.5 V @ 12 amp., \$2.50; Ditto 7.5 V. @ 3 amp., 5 V. @ 8 amp., \$3.50; Thordarson choke 150 ma. 8 hy., \$1.75; 4 Pyrex xmitting feed-thru, 1 1/2" dia., 2 1/2" long, 75c ea.; also 3/4" and 1" stand-off pillars, and 6- and 7-prong tube sockets. S. M. Sparks, RFD # 5, Spartanburg, S. C.

**FOR SALE**—Have good Readrite set tester #720-A, and Yankee tube tester and rejuvenator #S-550 (modernized). Will sell or trade for phono motors or recording unit. Wilfred H. Simpson, Armstrong, B. C., Canada.

**FOR SALE**—Have many good used tubes to sell at half price, such as 24, 27, 56, 57, 58, 78, etc. Sell or trade. What have you? Weir Cove Radio, 508 Garden Way, Hollidays Cove, Va.

**URGENTLY NEEDED**—V-O-M or foundation meter. Would like Superior pocket lab model 1200 or 1240, or Superior utility tester. Have for sale or trade crystal pickup for strangled musical instrument and amplifier. H. C. Caldwell, P. O. Box 394, Spartanburg, S. C.

**WANTED FOR CASH**—Good used Meissner analyst. J. I. Freeman, 5517 W. Poplar St., Philadelphia, Pa.

## CASH WAITING FOR YOUR UNUSED PARTS AND EQUIPMENT

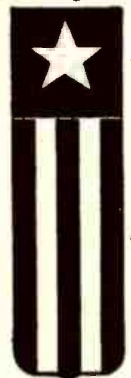

Going into the Army or Navy? Giving up your service work for a war job? Or, even if you have remained in servicing work and have unused parts and equipment lying around, you can still render a patriotic service by advertising these for sale through the Sprague Trading Post. We'll gladly run your ad free.

Radio equipment of all types is badly needed today—and the Trading Post will help you dispose of it quickly. It is a golden opportunity to do your bit in keeping radios working on the home front and, at the same time, turn unused materials into cash, and avoid the possibility of obsolescence when the war is won and new, up-to-the-minute equipment is again available.

### Your Ad Run Free!

Send in your ad today. "Equipment for Sale" and "Equipment Wanted" ads of an emergency nature will receive first attention. Sprague reserves the right to eliminate any ads which do not fit in with the spirit of this special wartime advertising service. Different

Trading Post ads appear regularly in Radio Retailing Today, Radio Service Dealer, Service, Radio News, and Radio-Craft. Please do not specify any certain magazine for your ad. We'll run it in the first available issue that is going to press.

Dept. RC-41

**SPRAGUE PRODUCTS CO., North Adams, Mass.**

# SPRAGUE CONDENSERS KOOLOHM RESISTORS

Obviously, Sprague cannot assume any responsibility, or guarantee goods, services, etc., which might be exchanged through the above advertisements

# The Question Box

All queries should be accompanied by a fee of 25c to cover research involved. If a schematic or diagram is wanted, please send 50c, to cover circuits up to five tubes; for five to eight tube circuits, 75c; over eight tubes, \$1.00.

Be sure to send the fullest possible details when asking questions. Give names and MODEL NUMBERS when referring to receivers. Include schematics of your

apparatus whenever you have such. Serial numbers of radios are useless as a means of identification.

All letters must be signed and carry FULL ADDRESS. Queries will be answered by mail, and those of general interest reprinted here. Do not use postcards—postmarks often make them illegible.

No picture diagrams can be supplied. Back issues 1942, 25c each; 1941, 30c each; 1940, 35c each. Any issue, prior to 1940, if in stock, 50c per copy.

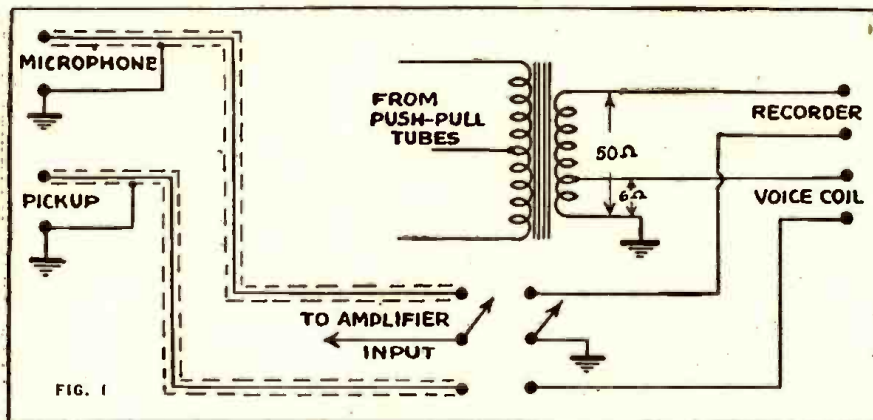

## ? PLAYBACK CIRCUIT

I would like to have a circuit for hooking up a recorder, speaker, microphone and pickup to my amplifier, for recording and playback.—F. L. S., N. Y. C.

**A.** The circuit shown is suited for your recorder, which has an input impedance of 50 ohms. Since you did not state the impedance of your voice coil, I am assuming it to be 6 ohms. A voice coil of different impedance would, of course, have to be tapped into the correct section of the output transformer. (See Fig. 1.)

In the "up" position, the amplifier is ready for recording—in the "down" position, for playback.

## ? A 32-VOLT RECEIVER

I would like to have a diagram for a 3-tube set to work from a 32-volt lighting system. Do not want a circuit using a vibrator.—R. E., New York City.

**A.** The miniature type low-voltage tubes make it possible to design a set that will work with reasonable efficiency on 32 volts. The two coils should be of the iron-core R.F. type, for greater sensitivity. The audio frequency choke in the plate circuit of the 1S5 may be any small choke—the secondary of a burned-out audio transformer has been used here with good results. (See Fig. 2.)

If a ganged or grounded variable condenser is used on a metal chassis, ignore the connection from the first .00035 variable to the junction of the grid coil and the .05 grid-circuit by-pass condenser, as a connection from that point to ground would short the a.v.c.

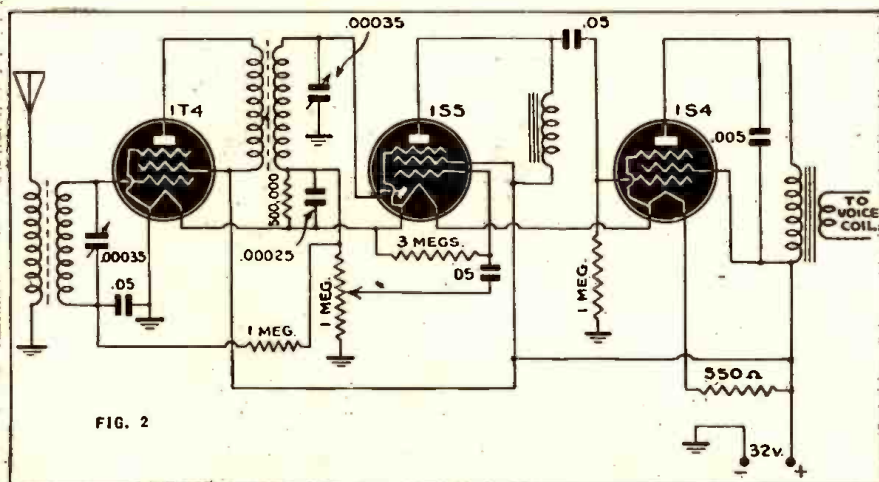

## ? D.C. CONDENSER TESTER

I would like to get a circuit for a condenser leakage tester, using a 6X5 as a power tube. The D.C. voltage I want is 50—150—200—400—500. I would also like to be able to check electrolytic condensers on it.—J. F., Chicago.

**A.** The leakage tester shown can be used with any one of several rectifier tubes, such as the 80, 5Y3-G, 6X5, etc. The switch is placed on the .05 condenser to check paper condensers, and on the shunting 30,000-ohm resistor for electrolytics. (See Fig. 3.)

A small receiver power transformer may be used to supply the high voltage required. It should be hooked up in a half-wave circuit, ignoring the center tap. Should the output voltage be too high, it may be reduced by using a resistor in place of the filter choke.

Extreme care should be taken in the wiring of this circuit, and excellent insulating material used throughout. Many of these home-made leakage testers fail to work because of other leakage paths through the device. Using a larger neon lamp sometimes helps in cases like these, but the only correct way is to insure that there is no leakage.

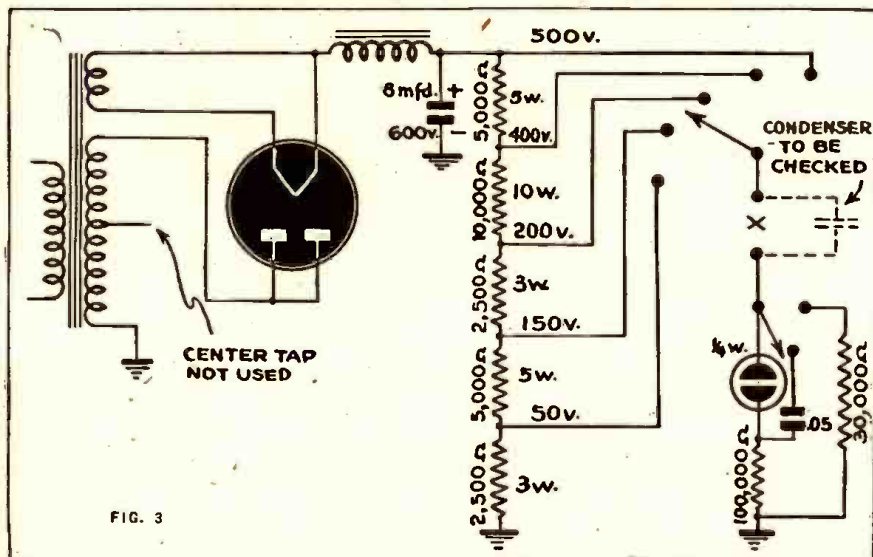



**Echophone Model EC-1**

(Illustrated) a compact communications receiver with every necessary feature for good reception. Covers from 550 kc. to 30 mc. on three bands. Electrical bandspread on all bands. Six tubes. Self-contained speaker. 115-125 volts AC or DC.

**Echophone Radio Co., 540 N. Michigan Ave., Chicago 11, Illinois**



# The Radio Experimenter

## POWER PACK FOR BICYCLE RADIO

This power pack (see diagram) uses a 31 tube with two flashlight batteries in parallel for filament power. The batteries last very well since the current drawn from each is only about .05 amp. For a power transformer, I used the core of an old output transformer taken from a discarded A.C.-D.C. set.

The ratio of the transformer was about

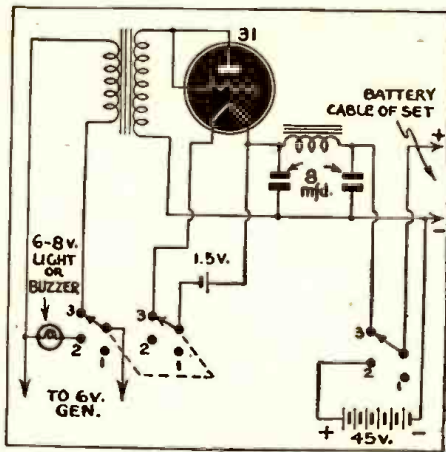

1 to 15 and I wound the secondary with wire taken from field coil of an old 5" speaker. For the primary I used wire about twice the size of the secondary wire. The choke I used drops about 15 volts. I install the radio and power pack in a small basket hooked on the handle of the bicycle. Later, I installed in the basket, a regular size "B" battery with a switch. When riding, I used the generator. When I stopped, I switched the "B" battery on.

The switch is connected so that when in riding position the "B" is off and the generator on. When the switch is in the stopped position, the "B" battery is on and the generator is off. At the same time a buzzer (or a light) is thrown across the generator. If I start to ride with the switch in this position, the buzzer (or the light) warns me to switch to the riding position, thus saving expensive battery power.

For an antenna, I used an old telescope fishing pole, because the loop antenna in the set was too directional to be practical.

This hook-up is very economical and satisfactory. It should be popular in times like these because it can be built from old parts and also uses for the most part, foot power.

M. ARCHAMBAULT,  
Terrace, B. C., Canada.

## OLD-TYPE TUBES IN T.R.F. SET

The following diagram is for a cheap but powerful 4 tube T.R.F. Receiver. The tubes are non-critical ones and will outlast the new types. Most of the parts can be found in the junk box. The antenna and R.F. coil are standard coils (Meissner were used in this case). A two gang 365 mmfd. condenser is used and reception is very good.

It will be found necessary to shield the

57 tube to obtain maximum efficiency, and the coils of course must be enclosed in shield cans to prevent oscillation. I have mounted the whole works including the power supply on a chassis 5 x 9 x 1/2.

This set was designed to make use of available parts which are not on priority.

WILBUR HAIT,  
Camden, N. J.

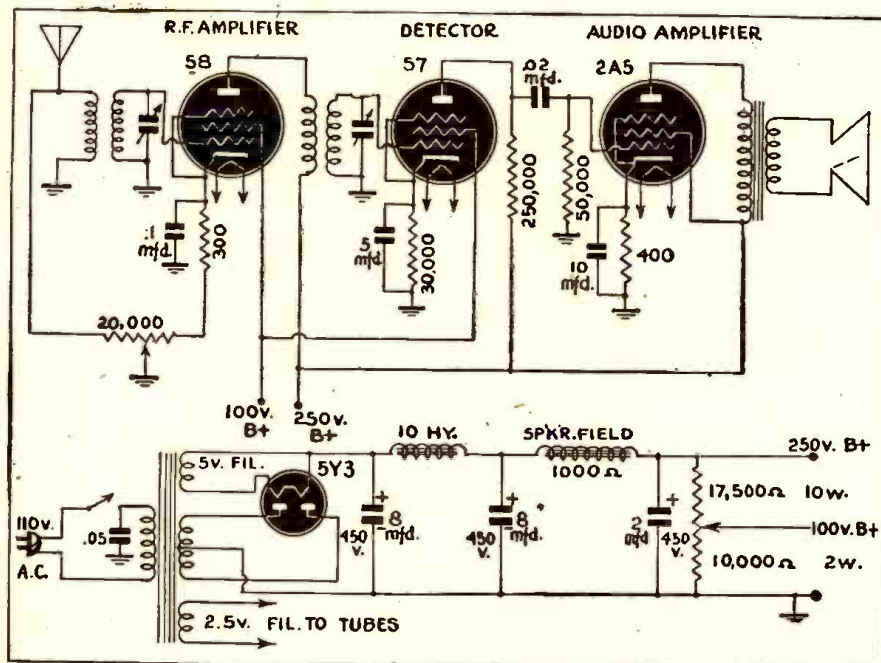

## SPEAKER FIELD SUPPLY

A simple field supply for a dynamic speaker can be assembled from a condenser, a forty-watt lamp, and 25Z5 rectifier tube.

Wired as shown, the circuit will supply approximately 100 milliamperes at 130 volts when used with an eight-microfarad condenser. Increasing the condenser size increases the output voltage. The forty-watt bulb serves as a series resistor.

CHARLES GRIFFITH,  
Bakersfield, Calif.

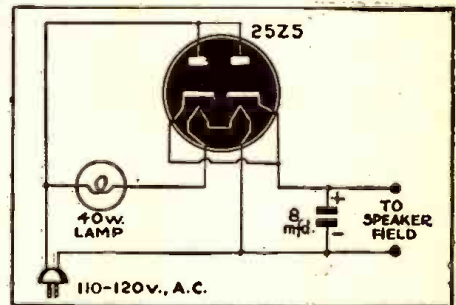

## 1-TUBE AUDIO AMPLIFIER

The following Audio Amplifier uses a 117L7-GT which gives excellent results as an amplifier for headphone sets and similar one and two tube receivers.

Most of the parts, with the possible exception of the tube, may be found in the average junkbox. The values are non-critical and substitutions may be made to suit the builder. As a guide, R1 may be 100,000 ohms to 1 megohm; R2 about 100 ohms; C1 and C2 8 to 24 mfd. each; C5 .0005 to .005, depending on the speaker or phones and the taste of the listener; C6, .01 to 0.1 mfd. C3 and C4 were 2 10-mfd., 25-volt condensers that happened to be on hand—anything from 5 to 25 microfarads will work very well here. If the amplifier is used with headphones an output transformer should be provided.

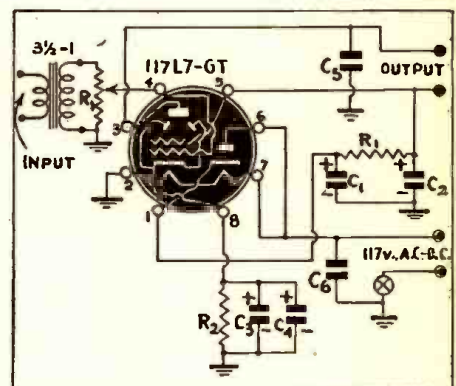

The 117L7-GT, which operates directly off the 110 volt line, eliminates the need for a line-cord resistor, which incidentally is impossible to buy in Canada. The unit required no output transformer with the magnetic speaker used. However, this will depend on the type of speaker used by the builder.

J. A. REID,  
Hamilton, Ontario, Can.

A MESSAGE TO RADIO AND  
ELECTRONIC MANUFACTURERS

# SUPPLIES!

Postwar competitive battles will be won by getting the right supplies to the right spot at the right time!

## YOUR FIELD COMMANDERS

—the technicians, servicemen, and dealers, have been waiting and waiting these long war years for replacement parts and sets. They are always hungry for news of what is available, or at least, of what the manufacturers are doing. Eagerly they search the pages of RADIO-CRAFT—their main source of information.

The radio or electronic manufacturer who has no merchandise to offer at this time might well keep in the good graces of his outlets, by maintaining contact through RADIO - CRAFT—the leader in this highly concentrated field.



Certainly, with the war taking a favorable turn, this is the proper time to start re-establishing friendship with OUR readers—another name for YOUR sales outlets. Notwithstanding high QUALITY readership, we can also offer QUANTITY circulation.

# PARTS!



## Leadership in Readership

We wish you manufacturers could be with us while we open the incoming mail. You would see how these technical middlemen—the very ones you will be seeking again for your “sales representatives”—appealing to our editors for help on this or that problem. Some ask for the latest “dope” on technical developments—some request

information on parts, others send in notes and suggestions which we print for them.

The picture you would get is that your future sales outlets regard RADIO-CRAFT as virtually their own publication. As a matter of fact, they are inclined to feel slighted if a manufacturing supplier does not keep them informed through their favorite medium.

# RADIO KINKS

## FEED-BACK OSCILLATOR

Every experimenter has experienced audio feed-back at one time or another, but I believe this application of it to code practice to be original. The circuit consists of an old telephone receiver and microphone connected in series with key and battery.

Of course the telephone parts must be placed next to each other so that feedback is possible. The click in the receiver upon closing the key is picked up by the mike, starting an audio howl which continues as long as the key is depressed.

IVAN H. WALKER,  
Mt. Horeb, Wis.

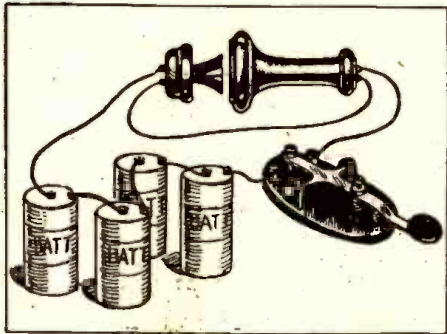

## CURTAIN-ROD ANTENNA

An ordinary curtain rod of the telescoping variety makes a neat antenna for a portable radio. I find that signals are considerably better with such an aerial.

One end is cut off and two holes drilled to take the machine screws that hold it to the side of the portable. A collar with a set screw is slipped over the inside rod, so that when it is tightened the antenna will remain extended in spite of any jars it may receive. Thus it can be used in a car, or even carried while the antenna is extended.

LOUIS JOLIVET,  
Haverhill, Mass.

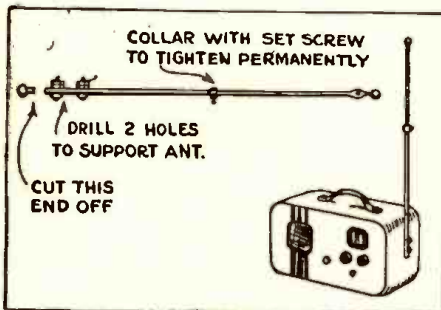

## SOLDERING FLUX

Many of the so-called "non-corrosive" pastes consist of a mixture of muriatic acid and grease. If the paste becomes unduly warm—as might be the case if a hot soldering iron were placed in it—the two components separate and the paste becomes anything but non-corrosive.

One type of soldering flux widely used

by manufacturers of radio and electrical equipment may be easily made by any serviceman. To a given quantity of alcohol, add as much powdered resin as can be dissolved in it.

A small amount of this solution is applied directly to the connection to be soldered. This is usually done by means of a small paint brush. If ordinary wire solder is used, there is little danger of having a "resin joint." This is one of the truly non-corrosive soldering fluxes.

PAUL BAUMAN,  
St. Cloud, Minn.

## REPLACEMENT FOR PUSH-PULL

We fellows who "keep them playing" in rural little towns, where spare parts are only available from our stock, and our stock being limited nowadays by circumstances known to all, sometimes meet the following problem: a burned out primary in an audio-push-pull-coupling transformer. You look through your stock and won't find a spare. Of course there is the solution of figuring out a combination of resistances or resistors that probably won't work satisfactorily.

I've done as follows and have got excellent results, and three sets that I've "kept on playing" are now working with a transformer picked out from the unforgettable "junk box." The transformer to substitute was a push-pull audio coupler (two leads from the primary and three from the secondary) with (as usual) the primary burned out. I found a 3 to 1 transformer (two leads for the primary and two to the secondary). I just soldered the leads of the secondary over the outer leads of the affected one.

The sets have only lost about 10% of volume and, as the owners say: "They are working *muy bien*" (Spanish for "very well").

GILBERTO GARZA G.,  
Cerro Azul, Ver. Mexico.

## USE FOR OLD AUDIOS

Old audio transformers may be used for many jobs that call for small chokes. Simply hook them up as shown.

I first tried this when I wanted a choke to connect a magnetic speaker or headphones to a small radio. They can be used also in the plate circuits of amplifiers where resistors are called for. In battery or 115-volt sets changing the plate resistor for one of these audio chokes makes quite an increase in the volume.

AL HAUSER,  
Indianapolis, Ind.

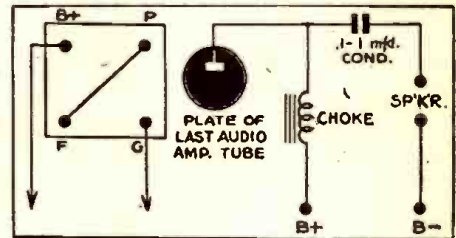

## PUSH-PULL TRANSFORMER

I constructed a general purpose amplifier with a push-pull output stage, but I could not get a push-pull transformer with a center-tapped secondary. I had two single transformers from an old Fada 480, so I connected them as shown in the illustration.

ERNEST W. CARLSON,  
Oswego, Mont.

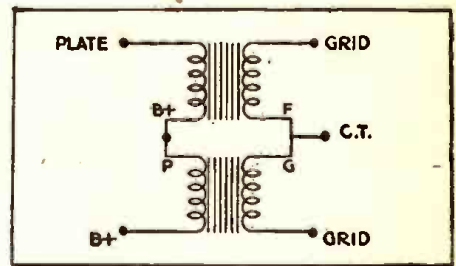

## BRITISH HUMORIST ENVISIONS NEW ROCKET

A NEW type of "radio flying rocket" is suggested by the British radio humorist "Free Grid," in his column "Unbiased" (*Wireless World, London*). His suggestion is to fly United Nations radio programs to the listening public of Germany by means of special planes.

"Free Grid" points out that much of our short-wave effort is wasted, as the folk of the Fatherland are for the most part provided only with primitive broadcast-band *Volksempfänger*s whose limited range prevents them from hearing even the broadcasts on their own frequencies now being transmitted from stations around the edges of the occupied areas.

"My proposal," he says, "is simply to take Mahomet to the mountain by clearing out the bomb racks from a few of our egg droppers and installing therein a low-powered transmitter. By flying over selected German cities at stratospheric height well

out of range of 'flak,' these radio bombers would literally be able to force their programmes onto the *Volksempfänger*s, the very unselectiveness of which would make this all the easier to accomplish.

"Nor would it be absolutely necessary for the studio to be in the plane. This could still be in London, one of the ordinary BBC SW transmitters being used to link it up with a short-wave receiver in the tail of the plane, the propaganda programmes being then rebroadcast by the medium-wave transmitter.

"I need hardly add that there would be little object in Adolf copying the idea, since anybody over here who desires to do so is already able to listen direct to all the Axis propaganda they want. If any of you apart from political obstructionists, can see any technical snags in the idea, let me know."





## STARTING JANUARY 18<sup>TH</sup> IT'S UP TO YOU!

**S**TARTING January 18th, it's up to you to lead the men and women working in your plant to do themselves proud by helping to put over the 4th War Loan.

Your Government picks you for this job because you are better fitted than anyone else to know what your employees can and should do—and you're their natural leader. This time, your Government asks your plant to meet a definite quota—and to break it, *plenty!*

*If your plant quota has not yet been set, get in touch now with your State Chairman of the War Finance Committee.*

To meet your plant quota, will mean that you will have to hold your present Pay-Roll Deduction Plan payments at their peak figure—and then get at least an average of one **EXTRA \$100 bond from every worker!**

That's where your leadership comes in—and the lead-

ership of every one of your associates, from plant superintendent to foreman! It's your job to see that your fellow workers are sold the finest investment in the world. To see that they buy their share of tomorrow—of Victory!

That won't prove difficult, if you organize for it. Set up your own campaign right now—and don't aim for anything less than a 100% record in those *extra* \$100 bonds!

And here's one last thought. Forget you ever heard of "10%" as a measure of a reasonable investment in War Bonds under the Pay-Roll Deduction Plan. Today, thousands of families that formerly depended upon a single wage earner now enjoy the earnings of several. In such cases, 10% or 15% represents but a paltry fraction of an investment which should reach 25%, 50%, or more!

Now then—Up and At Them!

**Keep Backing the Attack!—WITH WAR BONDS**

*This space contributed to Victory by RADIO-CRAFT*

*This advertisement prepared under the auspices of the United States Treasury Department and the War Advertising Council*

RADIO EQUIPMENT HINTS

# SYLVANIA SERVICEMAN SERVICE

by  
**FRANK FAX**



"RADIO EQUIPMENT HINTS" describes testing equipment so important to every radio man's service bench. Hints on how to use this equipment will save you time in tracing and locating receiver troubles.

There are 59 pages of clear information from radio tube headquarters. The volume is liberally illustrated with photographs, circuits and graphs.

Read over the subjects in the Table of Contents, reproduced below:

## Radio Equipment Hints

### Table of Contents

	Page
Slide-back Vacuum Tube Voltmeter.....	6
Power Unit for Slide Back V.T.V.M.....	10
A Simple Peak Voltmeter.....	14
The Vacuum Tube Voltmeter as a Service Tool.....	18
The Diode V.T.V.M.....	46
The Grid Rectifying V.T.V.M.....	58
The Slide-back type V.T.V.M.....	68
The Reflex type V.T.V.M.....	80
The Inverted Triode type V.T.V.M.....	90
The Moullis type V.T.V.M.....	90
The Induits Impedance Diode V.T.V.M.....	91
The Electric Eye V.T.V.M.....	98
Use of the Electric Eye V.T.V.M.....	10
Know your Tube Tester.....	97
Service to Servicemen.....	91

This is the second of the new Sylvania "Hints" series.

"Radio Equipment Hints" is FREE. If your jobber does not have copies, write to: FRANK FAX, SYLVANIA, EMPORIUM, PA.

**SYLVANIA**  
ELECTRIC PRODUCTS INC.  
RADIO DIVISION • EMPORIUM, PA.

# Australian Champion Hi-Fi Amplifier

THIS simple amplifier is a national champion. It is the winner of a contest staged by the Melbourne (Australia) radio paper, "Listener-In," in conjunction with their Australian DX Radio Club.

Forty-two amplifiers were entered, and ten of these made the finals. These ten were allowed to play three recordings each, after which the judges announced their decisions. Proponents of the triode will be interested to know that the contest narrowed down to a struggle between this amplifier and another push-pull 2A3 job.

That simplicity and high-fidelity go together is amply demonstrated by this set. Triodes are used throughout, as is resistance coupling. The phase inverter is the famous Australian "kangaroo" circuit. The plate resistor, and its balancer between the 6C5-G cathode circuit and ground, are kept to a low value, in the interests of high-fidelity. These resistors are often 100,000 ohms or higher, but in this amplifier are limited to 50,000.

The 6N7-G is then used as a straight push-pull amplifier. The plate resistors on these tubes are also kept down—to 100,000 ohms in this case—and grid leaks of the 2A3 are 250,000 ohms, the signal being transferred through .1-mfd. condensers. A fairly high voltage is used on the 2A3's. This also increases the efficiency of the resistance-coupled stages slightly.

Excellent filtering is a feature of this circuit. Even the push-pull output of the 6N7 circuit is filtered, in spite of the fact that most variations in this circuit would be self-neutralized. A 20,000-ohm resistor and an 8-mfd. condenser act as filter in the plate circuit of the first stage. No cathode condensers are used anywhere in the amplifier.

The runner-up job also used 2A3 output, preceded by a 6V6 phase-changer. Fixed bias featured the circuit, which was nosed out by the winner only after a stiff battle.

The constructor of the champion gives credit for his victory to the infinite baffle used with his amplifier. Correct speaker loading and proper reproduction of low notes made for a noticeable increase in

quality as compared with the same outfit used with an ordinary baffle, according to him. Full constructional details of this baffle are given in the sketch.

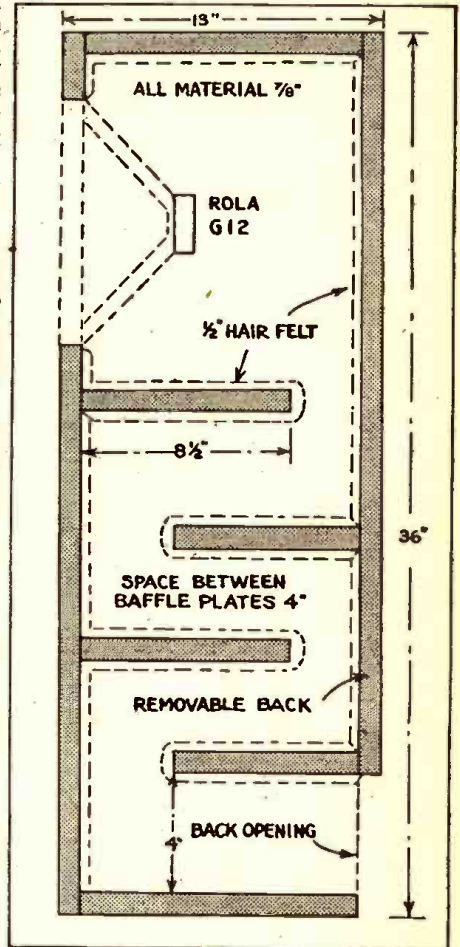

The speaker cabinet is of the infinite-baffle type, greatly improving low-note reproduction.

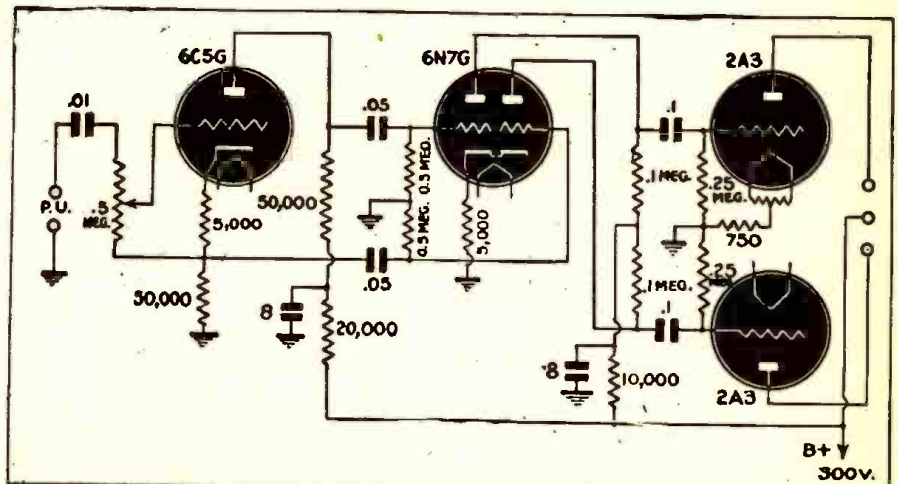

The single triode is used as a phase inverter, and the 6N7G as a straight push-pull amplifier stage. Triode tubes, excellent filtering and low resistor ratings all contribute to its fidelity.

## ENEMY RADIO OUT-OF-DATE

"GERMAN radio equipment is five years behind our own in design, components, and construction," Captain James P. Lipp, Signal Corps, has reported to the Chief Signal Officer. This seems to be due, the Captain explained, to the fact that the Germans standardized their radio apparatus during 1934-1938 and have failed to attempt further improvements.

"There is no doubt that our radio equipment is superior in electrical design. Examination of the Nazi radio sets captured revealed them to be obsolete as compared to present American standards. The Italian radios were definitely inferior, not only to our equipment, but to their erstwhile allies' too.

"However, Jerry radio sets are mechanically well-built and have a great deal of strength. They are heavier than ours and can withstand a lot of punishment. Those that we have tested were certainly not made for Africa. They lacked waterproofing and were not dustproofed. In many cases stop-gap measures were used. For instance we have noticed that tape and various sealing compounds were used in an attempt to make sets resistant to corrosion and to exclude dust. An obvious fault was the lack of impregnation of coils and transformers to keep out moisture.

"German Signal prisoners of war whom I have had a chance to interview did not seem to be very well trained along technical lines," Captain Lipp said. "They seem to be fairly good operators, but they do not seem very well versed in theory or in maintenance. In many cases we have picked up radio sets that were intentionally sealed to prevent tampering so that Germany operators could not attempt their own repairs.

"Our own boys, of course, having 'Yankee Ingenuity,' think nothing of repairing or improvising their own equipment if they have the tools and parts."

Up to the present time, Captain Lipp declared, it has not been necessary to use captured equipment, since our forces have been adequately provided with communications equipment. Enemy equipment is eagerly sought for, however, for purposes of study by Signal Corps Intelligence services.

Although some of the captured enemy items come back to Allied Force Headquarters through regular channels, Captain Lipp and his men scout close to the front lines for finds. At one stage in the latter phase of the Tunisian campaign, they attached themselves to the British Eighth Army and were proceeding down a valley when they found themselves in the midst of an artillery duel between British and German batteries.

At one time, Captain Lipp began receiving a large amount of oval shaped instruments, tagged "loudspeakers." He soon discovered that they were really German land mines, and these misdirected instruments of destruction were immediately ordered rerouted to the Ordnance base for utilization or disposal, as being too "powerful" for Signal Corps use.

The National Film Board of Canada is using television to familiarize Americans with the Canadian people. Recent documentaries televised in the United States by CBS under the title, "Peoples of Canada," include Canadian subject matter and international subjects, especially shots of Canadians on the fighting fronts in Europe, Africa and Asia.



• The boy's been in a tight spot . . . "lost angel face" tells his comrades that the plane has a damaged wing . . . but the "baked a cake" tells 'em that his bomb load reached its target . . . and the "I'm coming in" tells us that thanks to the finest equipment in the world, another American fighting man has had a fighting chance.

Pincor dynamotors are part of his communications equipment. One of these compact, featherweight little motors is used to power the radio and phone apparatus that helped to take him through and bring him back.

**PINCOR**  
Products

**BUY MORE  
WAR BONDS**

Dynamotors	Converters	Generators
DC Motors	Power Plants	Gen-E-Motors

### PIONEER GEN-E-MOTOR

5841 WEST DICKENS AVE., CHICAGO 39, ILL.  
Export Address: 25 WARREN ST., NEW YORK 7, U.S.A.  
Cable Address: SIMONTRICE, N. Y.

# UNFAILING PRECISION

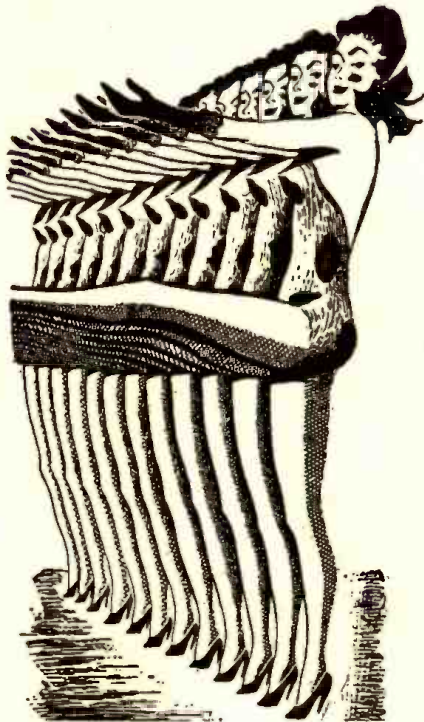

**IN THE new General Electric line of SERVICE TESTING EQUIPMENT, unfailing precision is just one of many invaluable features. Designed by the famous G-E electronic laboratories for radio service men, service dealers and others—this line gives you a wide selection of portable, compact apparatus for accurate and rapid maintenance and testing work.**

The units include: G-E unimeters, tube checkers, audio oscillators, oscilloscopes, condenser resistance bridges, signal generators and other utility instruments for testing radio electronic circuits and component parts.

These dependable G-E units are now in production primarily for the Armed Forces. But they may be purchased on a priority if you are engaged in war work. After victory, of course, the full line will again be available to everybody. . . . General Electric, Schenectady, N. Y.

FREE CATALOG



ELECTRONICS DEPARTMENT  
GENERAL ELECTRIC CO.  
Schenectady, N. Y.

Please send, without obligation to me, the General Electric Testing Instrument Catalog R-1 (loose-leaf), for my information and files.

Name \_\_\_\_\_

Company \_\_\_\_\_

Address \_\_\_\_\_

**GENERAL ELECTRIC**  
Electronic Measuring Instruments

## OSCILLATORS—HOW THEY WORK (Continued from page 209)

Centigrade temperature change is called the temperature-frequency coefficient or, more commonly, the temperature coefficient.

If the frequency increases with the temperature, the crystal has a positive temperature coefficient. Conversely, if the frequency decreases with rises in temperature, the crystal has a negative temperature coefficient. When a small change in frequency is accompanied by a temperature change, the crystal has a low temperature coefficient.

An X-cut crystal has an average temperature coefficient of from -10 to -25 cycles per megacycle per degree Centigrade. A V-cut crystal has a coefficient of from -20 cycles to +100 cycles per megacycle per degree Centigrade. V, AT and LD cuts have a very low temperature coefficient.

From maximum stability a crystal oscillator should have just enough inter-electrode feedback to sustain oscillation. Increasing the feedback beyond this point means that excessive power will have to be dissipated by the crystal. This may result in fracture. The holder should be designed for good heat dissipation and for the particular crystal cut.

We have seen from our frequency formula,

$$F = \frac{1}{\sqrt{2\pi LC}}$$

that the frequency is proportional to the square root of the product of L and C. This formula is applicable when computing the frequencies of audio and sub-audio resonant circuits. In this formula, L and C are computed in Henries and Farads respectively.

When L and C are measured in microhenries and microfarads, the formula for frequency is

$$F = \frac{159,000}{\sqrt{2\pi LC}} \quad (1)$$

when L = microhenries and C = microfarads.

Knowing the inductance and capacitance in a circuit, the formula above may be used to determine the resonant frequency of the circuit.

### HIGH-FREQUENCY CIRCUITS

As the ultra-high frequencies are approached, smaller and smaller inductances are used in the tuned circuits. When an inductance is coupled between two elements of a tube, the interelectrode capacity between the elements will serve to tune the

inductance to the lowest possible frequency. Theoretically a direct connection between the plate and grid of a tube will be the smallest possible inductance that can be used and the tube would oscillate at its highest frequency. This combination will not work under ordinary conditions with average tubes because of losses due to poor dielectrics used as tube base insulators and

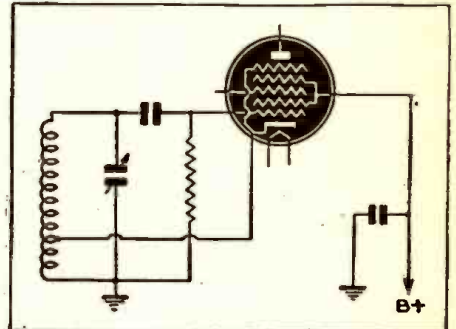

Fig. 9-b—The electron-coupled circuit applied to a superheterodyne converter. Good at high frequency, it is much used in modern radios.

also in other parts used in tube construction. This small inductance could only be used in special high-frequency tubes designed to have low-loss insulation and low inter-electrode capacity.

Coil and condenser combinations may be made to oscillate at frequencies up to approximately 175 megacycles but under these conditions the "Q" of the combination is exceptionally low due to resistive and skin losses in the coil and dielectric losses in the condenser. The comparatively long leads necessary to connect the combination to the tube are factors that tend to lower the resonant frequency of the circuit.

Two parallel wires cut to a length equal to one-quarter of the wave length of the desired frequency will resonate if they are joined together at one end. This type of circuit is characterized by a low impedance across the closed end and a very high impedance across the open end. Some of the power in this type of circuit is lost due to its radiation.

A co-axial or concentric line may be used as the parallel-lines circuit with greater efficiency. This is due to the fact that there is no radiator because the outer tubing acts as a shield and also because of the higher "Q" attainable. The parallel-lines oscillator

Fig. 10—A triode-hexode, of the type represented by the 6K8, is illustrated here. This tube is less liable to "interlocking" effects at high frequencies than any other type of converter-mixer tube.

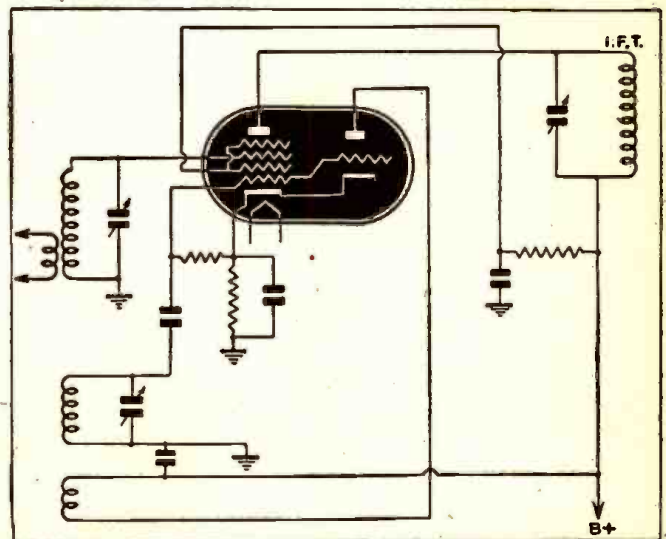

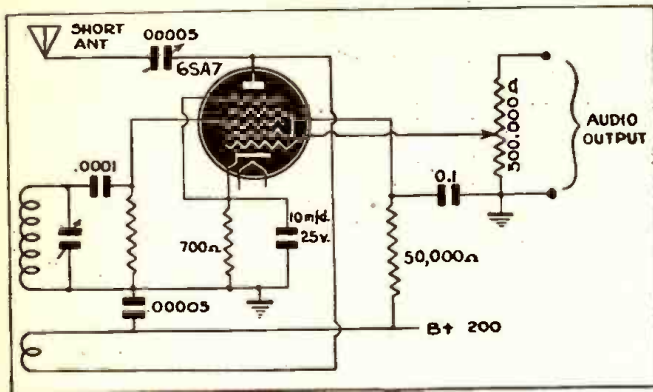

Fig. 11 — A common type of phonograph oscillator, designed to play records through an ordinary radio without making any connections to the set. It is a miniature transmitter, modulated by the phonograph.

high amplification at the frequencies used by short-wave broadcast stations. Amplification at a lower frequency is desirable.

The superheterodyne uses an oscillator adjusted to a frequency that differs from the incoming carrier signal by a definite number of kilocycles. The signal from this oscillator is fed into a "mixer" tube where it is combined with the incoming signal to give two frequencies, equal to the sum and to the difference of the combining frequencies. Assuming that the incoming signal is at 2,040 kilocycles and the oscillator is operating at 2,496 kilocycles, then frequencies of 4,536 and 456 kilocycles are present in the output of the mixer tube. A sharply fixed tuned transformer is connected between the output of the mixer and the input of the following amplifier. This transformer circuit is tuned to the difference fre-

(Continued on following page)

circuit can be made with very high "Q" because tubing of large diameter may be used to supply a large conducting surface for the R.F. currents.

When a circuit of this type is connected to a vacuum tube, its resonant frequency will be lowered because of the tuning effect of the interelectrode capacities.

Fig. 5 shows the use of parallel lines forming the tuned circuit of an ultra-high frequency ultra-audion oscillator. The tube elements have a tendency to load the lines and thus reduce the "Q" of the circuit. If the tube is connected to some points away from the opening of the lines, the loading effect will be reduced. A shorting bar may be used to vary the resonant frequency of the combination.

Any long leads in the immediate vicinity of the tuned circuit will cause instability and power losses unless these leads have their inductance cancelled by inserting inductances in the leads that will tend to cancel each other. The inductances in Fig. 5 are inserted in the filament leads to cancel the inductance and there will be no r.f. potential difference between the filament and the closed end of the tuned circuit. If a cathode type tube is used, the inductance of the heater leads need not be taken into consideration.

Two tubes may be operated in push-pull as oscillators to secure greater power output and increased frequency stability. The frequency is stabilized because the load is connected to the plate circuit, which when tapped to the lines away from the open end will result in maximum loading and utmost instability. Fig. 6 shows a push-pull tuned plate tuned grid oscillator. The grid circuit is used for frequency control and the grid tap should be made at the point where maximum stability is obtained.

A coil and condenser combination may be used in the plate circuit of Fig. 7 with very little decrease in efficiency and for greater ease of tuning.

Concentric lines may be applied to the ultra-audion as well as tuned grid tuned plate oscillators as shown in Fig. 8. The operation is the same as in the lower frequency oscillators and a tuning condenser may be used to tune the lines when the shorting bar and taps cannot be readily changed.

The length of the parallel line and concentric line elements may be calculated from the following formula:

One half wave length (inches) equals  
5906

Frequency (megacycles)

One half wave length (meters) equals  
150

Frequency (megacycles)

The part that the oscillator plays in today's superheterodyne receiver is a very

important one. It is very difficult to design highly efficient amplifiers that will give faithful reproduction, good selectivity and



Your Meissner distributor will advise you on the Meissner replacement parts now available... while keeping our facilities devoted to the manufacture of vital electronic parts for war needs we have been doing our utmost to keep a replacement parts stock in the hands of Meissner distributors... a service which we, here at Meissner, are doing to help keep 'em playing.

See your Meissner distributor today... he will tell you just what parts are available now.

  
Meissner  
MT. CARMEL, ILLINOIS

PRECISION-BUILT ELECTRONIC PRODUCTS



Supreme's New "Hairline Accuracy" Meter

ALLIED LIVES... Allied victories... depend upon the Communication waves and wires. These channels of contact **must** be kept open. Our fighting men rely on the accuracy, dependability and ease of operation of Supreme Instruments and Meters, assured by Supreme's 15 years of experience. Supreme Radio Testing Equipment Keeps Communications Open.

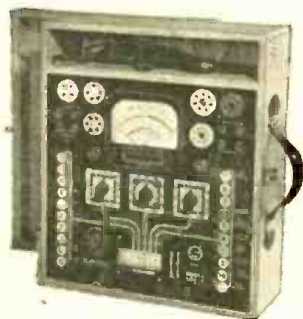

Supreme 504-A Tube and Set Tester

**SUPREME**

SUPREME INSTRUMENTS CORP.  
GREENWOOD, MISSISSIPPI, U. S. A.

## OSCILLATORS—HOW THEY WORK (Continued from previous page)

quency, 456 kilocycles, and the signal is then fed to further "intermediate" frequency amplifiers and then to the detector and audio amplifier. An amplifier with such fixed-tune transformers may be designed to furnish much more amplification than would be possible with the same number of tuned radio frequency stages.

The type of oscillator circuit is left to the discretion of the radio designer. The Colpitts, Hartley, Armstrong, T.N.T., T.G.T.P., E.C.O., or Pierce may be used with equal ease. The deciding factors will be the type of tubes used, stability and frequency. Separate oscillator and mixer tubes may prove the most efficient in some circuits but there are several types of multi-unit and pentagrid tubes that are excellent frequency converters and oscillators. Fig. 9, 9-a and 9-b illustrate the variations of oscillator and mixer circuits that may be used in superhet. radio receivers. The latest triode-hexode mixer, using a 6K8 or equivalent appears in Fig. 10.

The radio frequency oscillator is used in its various forms for:

- Radio Frequency Test Oscillator
- Frequency Meters
- Transmitter Control
- Short Wave Diathermy
- Wireless Photographs and Intercommunication

Basic circuits for these devices are shown in Figs. 1 to 12.

Increasing the size of L and C in most of these circuits will cause them to oscillate at a very low, audio frequency. They may then be used in the following devices:

- Audio Frequency Test Oscillator

Electronic Organs  
Code Practice Units  
It is hoped that the reader will finish these articles with a better understanding of oscillator operation and with the ability to recognize the various oscillator circuits wherever he or she (even the gals are reading this stuff these days) may see them and that a better understanding of the oscillator will help someone to do more than his share in the war effort.

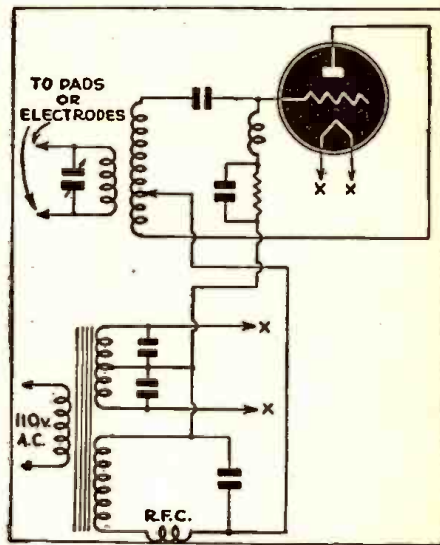

Fig. 12—A diathermy apparatus. The tube in circuit acts both as an oscillator and rectifier.

## MORE ERRORS IN METERS (Continued from page 207)

creased by as much as 5% (making their total error about 7%), if they are read while in an *inclined* or a *vertical* position. This is a fact most service men overlook; they are in the habit of placing the instrument in whatever position happens to be most convenient at the time and read it in that position disregarding any possibility of *unbalance error*. Then too, many such test instruments are mounted either vertically or in an inclined position on the panels of test benches. Such instruments should be checked for possible unbalance.

Any portable instrument may be checked quickly for possible unbalance by disconnecting it from all circuits and tilting it 60 degrees from the normal position, in any direction (or to several extreme positions) as illustrated at the right of Fig. 6. (A switchboard type instrument should be held with the axis of rotation of the moving system approximately *horizontal* and should be slowly turned through 360° about this axis.) If this causes considerable variation in the zero position of the pointer (more than about 2 per cent of the total scale length), the instrument is unbalanced and, until it has been rebalanced correctly it had better be used only in the position it was calibrated in. A perfectly-balanced instrument shows the same zero position of the pointer when placed in any position, and can therefore be used in any position.

### STRAY MAGNETIC FIELDS

The effect of a stray magnetic field on the indication of a permanent magnet,

movable-coil instrument depends on the nature and strength of the field.

Alternating stray fields have no perceptible effect on the reading of permanent-magnet moving coil instruments unless they are so strong that they demagnetize the permanent magnet somewhat, thereby causing the instrument to read *low* until it is repaired. Since alternating stray fields of such strength are rare, the radio service man need not concern himself about them. Strong alternating stray fields may cause errors in moving-iron type A.C. instruments, however, if they are of the same frequency as that of the current being measured. Some manufacturers surround the operating system of these instruments with a magnetic shield of laminated soft iron as a protection against such stray fields.

A strong stray magnetic field of constant direction and magnitude (such as that produced by an open dynamic speaker) will generally affect the indication of a moving-iron type A.C. instrument, and also that of a permanent-magnet movable-coil instrument, if it is sufficiently strong. Such a strong field changes merely the *strength* of the magnetic field in the instrument air gap, but not its *distribution*. The resulting error is therefore a *constant* percentage of the instrument indication, so long as the disturbing field is constant in amount and direction.

The service man should therefore be most watchful of his portable instruments when he uses them near strong stray magnetic fields—especially those produced by D.C.

If a portable instrument *must* be used in a location exposed to a strong stray field, two readings should always be taken for any measurement; then their *average* value should be ascertained and used. For the second reading, turn the instrument (or the stray field source) 180 degrees from its first position (about the axis of rotation of the moving element). Or, the instrument may be placed with its magnetic field at right-angles to the direction of the stray field, the latter determined by a small magnetic compass. It is preferable, of course, to make these precautions unnecessary whenever possible, by simply not exposing the instrument to strong stray fields.

If a non-shielded instrument is suspected of being within a disturbing stray magnetic field, test it for the presence of the field by taking a reading on it, then turn it through an angle of 90° and read it again.

The reading should be the same in each position. If it is not, the stray field is causing an error and the precautions specified here should be observed whenever a reading is to be taken.

When checking or calibrating instruments having metal cases, be sure to check with the instrument *in its case*, as the cover usually affects the calibration slightly.

### ELECTROSTATIC CHARGES

In dry weather (especially cold dry weather) instruments mounted in cases made of materials that are electrical insulators frequently collect an electrostatic charge. Electrostatic attraction or repulsion between the moving and stationary parts may result, and this may cause appreciable errors under certain conditions.

Cleaning the case or the glass face of an

instrument with a cloth is a good habit, but this can cause errors if the weather is such that rubbing the glass or the case (especially a Bakelite case) causes a static charge to accumulate on it. This electric charge may affect the deflection of the pointer at zero, or up scale. Oft-times what appears to be a normal "zero shift" on an instrument is really due to such electrostatic charges, and if the instrument is reset to zero under such conditions error will be introduced throughout the scale.

Fortunately the remedy for this trouble is simple. Either breathe upon the glass, or touch it with a slightly moistened finger. The moisture will cause the induced charge to disappear at once.

Another article on Meters and Measurements, by Mr. Ghirardi, will appear in the February issue.

### A VERSATILE TESTER

(Continued from page 215)

front panel. A3, A4, B4, B5 switch the various ranges, A1, A2, B2, B3 ensure that the H. T. supply voltage to the tube voltmeter and ohmmeter is switched on only in certain positions, and B1 selects the tube voltmeter ranges and switches the tube voltmeter set zero compensating circuit.

The chassis is fixed to a vertical frame-mounted front panel. The front panel is 9 in. by 12 in. and the chassis 8 in. by 10 in. A detachable cover is held by two screws on the vertical frame members; examination of the illustrations will make clear the layout details.

The diode head consists of two discs of insulating material of diameter 1 5/8 in. held together by two 3/16 in. brass pillars, 3 in. long. A length of plastic tube slides over this assembly, and is fixed by screws into the insulating discs. One of the discs has two tip-jacks, one for A.C., the other for D.C.; either a flexible lead or a rigid prod can be plugged into these jacks, according to the type of work in hand. The ground connection is a permanent short flexible lead terminating in a crocodile clip, which can conveniently be attached to the nearest part of the chassis.

The 0.05 μF diode input coupling condenser should have a high resistance and a low inductance; the tubular type with wire ends fits best into the small space available. It should be remembered that the working voltage of the condenser must be high enough to withstand the D.C. component when measuring an R.F. voltage at the plate of a tube. The condenser leads are as short as possible, and thus it is connected directly between the A.C. input socket and the diode plate clip. — *Wireless World*, (London).

Dentists have often restored articulate speech to toothless men and women, but the following is the first known example of a dentist restoring the silent voice of a radio station. It happened at an Army communication post somewhere in Africa not long ago. A Signal Corps lieutenant there had a problem—to install a powerful radio transmitter whose insulators had been badly broken in unloading. It occurred to him that the ceramic materials used for insulation might be repaired with the same cement used in making dentures. Accordingly, the Signal Corps officer enlisted the services of an Army dental officer. The damaged insulators were successfully cemented together and the station went on the air—its voice restored by a combination of dentistry and ingenuity.

# Get into RADIO now!

## WITH PREPARATION FOR CIVILIAN or U.S. GOVT. SERVICE

NOW, as never before, the urgent need for Trained Radio Men has created a tremendous shortage. The war has stimulated demand in both civilian and military fields. Regardless of whether you remain a civilian or enter military service, National Radio Training will qualify you for a real future, a good-pay job, responsibility, and a marvelous opportunity for advancement.



YOUR OPPORTUNITY TO LEARN

## RADIONICS

which includes

RADIO  
ELECTRONICS &  
TELEVISION

Electronics is growing by leaps and bounds. Defense radio installations are without limit. All sound systems and innumerable defense hook-ups require Trained men. Prepare yourself for these job opportunities. Enroll and Train by National's easy-to-grasp home method.

Qualify For These Jobs  
Radio Expert  
Broadcasting  
Aircraft-Marine  
Indus. Electronics  
Studio Technician  
Govt. Service  
Remanufacture



— THE START TO SUCCESS COUPON

## TESTED HOME TRAINING BY PROVED SHOP-FIELD METHOD

For 39 years National Schools has trained ambitious men for Top Pay trades. Squarely behind your Home Training are the modern, completely-equipped Training Shops of National Schools where we develop and prove every Shop Method Assignment sent to you. Every phase of your training is personally supervised by an established Faculty of practical, experienced instructors and engineers. They have developed progressive methods of training you in your own home based on actual shop practice. Unique training facilities give you Home Training based on Resident School Shop principles—methods not available from any other source, to our knowledge. You'll be amazed when you receive our Complimentary Lesson and full details.

### KEEP PRESENT JOB WHILE LEARNING

Regardless of previous education or age you can Train for Radio. Continue your present job. Earn while you learn. If subject to military service, all the more important that you get pre-training.

### MILITARY SERVICE

Prepare for Radio Service in Army and Navy. Get promotion in rank and increased pay almost from the start.

### SPECIAL OFFER

So that you can demonstrate to yourself the ease and rapidity of learning Radio at home, National Schools will present to you one Complimentary Lesson free, accompanied by Opportunity Book of Facts and Details about all branches of Radio. Use the Coupon. Mail it today!

## NATIONAL SCHOOLS

Los Angeles  
California

ESTABLISHED 1905



### MAIL OPPORTUNITY COUPON FOR QUICK ACTION

National Schools, Dept. 1-RC (Mail in envelope or 4000 So. Figueroa, Los Angeles, Calif. post in penny post)  
Mail me FREE, without obligation, one Lesson and Opportunity Book, with full details about how I CAN become a RADIO Technician.

NAME \_\_\_\_\_ AGE \_\_\_\_\_  
ADDRESS \_\_\_\_\_  
CITY \_\_\_\_\_ STATE \_\_\_\_\_

# 10,000

items under one roof

one quick central source  
for *Everything* in  
Electronics and Radio



**FREE!**  
Send for Today's  
Most Up-to-Date  
**BUYING  
GUIDE**

**REPAIR and  
REPLACEMENT  
PARTS  
AVAILABLE  
without priority**

**Save Time ...  
Call ALLIED First!**

*The world's largest  
stocks are centralized  
in this single arsenal*

of supply. Over 10,000 items from all leading manufacturers . . . for the Armed Forces, Radio Training, Research Laboratories, War Industries and Service Replacements. Our experienced staff helps speed delivery. Save time—simplify procurement—call ALLIED first! Thousands do.

Write, wire or phone Haymarket 6800.



**6 Radio Books for 75c**

Dictionary of Radio Terms. No. 37-751	10c	Radio Data Handbook. No. 37-754	25c
Radio Circuit Handbook. No. 37-753	10c	Radio Builders Handbook. No. 37-750	10c
Radio Formulas & Data Book. No. 37-752	10c	Simplified Radio Servicing. No. 37-755	10c
All Six Books No. 37-799 . . . . . 75c			

Write for Quantity Prices

ALLIED RADIO CORP., Dept. 2-A-4  
833 W. Jackson Blvd., Chicago, Ill.

Please send following books (.....c enclosed)  
 FREE  37-750  37-752  37-754  
 Buying  37-751  37-753  37-755  
 Guide  No. 37-799 (All Six Books)

Name.....  
 Address.....  
 City..... State.....

**ALLIED RADIO**

## A SERVICEMAN TO HIS SON

By EUGENE CONKLIN

Dear Son:

I received your letter today, and am glad to hear that you enjoy our "bull sessions via mail." So here goes for the latest installment of news from the "service front."

And service front is exactly what I mean. The battle of the busted radios is as stern as ever, and manpower recruitment is a real problem. With the WAC and WAVE enrollment drives becoming more and more comprehensive radio servicemen realize they can't depend on the feminine element as they have in the past. For that reason servicemen with locals in communities of fairish size are working hand in glove with high schools as follows:

The high school principal and the science instructor picks out 3 girls and 3 boys in second or third year HI. These students must be interested in radio, be mechanically and electrically apt (i.e., possess capable hands and a leaning toward simple Math.), must be willing to put in hours from 4-6 P.M. daily and in addition must be interested in eventual possible employment at the servicenter on a part time basis until they graduate and become eligible for drafting.

The candidates then report to the high school auditorium for three weeks, 4 nights weekly from 7-9. The serviceman lectures them on radio servicing fundamentals. At completion of three weeks preparatory training 2 are selected from the 6 students.

These two report to the servicenter nights after school and on Saturdays. They act as receptionists while the serviceman is out, make simple repairs, test tubes, and gradually become acclimated to the more serious types of radio-set-checking. They are paid at the rate of 30c an hour for the first month of work and then are increased to 50c an hour if they display sufficient talent.

Advantages of this tieup are many. The serviceman has to devote four nights weekly, it's true, for instruction but it's only for a three week period after which if he's lucky and the students prove adaptable, his nights are his own again.

A dark spot on the service horizon is the growing number of rackets that are be-

ing tried out in connection with radio servicing. There's the quick-thinking gent who peddles "whole sets of radio tubes" from door to door. He knocks at the door, points out the advantage to the customer of having a spare set of tubes on hand. Our friend then inspects the customer's radio, and leaves a set of supposedly new tubes. It may be long months before the customer has occasion to use the tubes. Then he finds that none of them even light. By that time our "door to door expert" has decamped with his ill gotten gains.

Cut from the same pattern of cloth is the charming "individual who inspects radio sets for free." His story is that he travels from town to town repairing radios like the old time piano tuners. Of course you've guessed it. He puts on a front, makes a show of checking the radio, then soaks the customer a nice fat juicy fee. Ordinarily the real dyed in the wool serviceman wouldn't worry about such "small fry pests." But today sets come into service shops far worse than they ought to be, because of some supposed expert's tinkering.

You'll be happy to know that in the communities near service camps in any service repairmen are putting this rule into effect. "Get the soldiers radio work done first." They can't always give "on the spot repair" but they can and are tackling Service's radio work first. At first civilians used to kick—but not any more—now they take such treatment as a matter of course.

Some of the boys are giving men in uniform a special 75c an hour labor rate instead of the usual "buck." Others are knocking off a few pennies on every job done for the khakis. These service repairmen feel it's the least they can do for the boys doing the fighting. Another comforting ray is that the battery shortage for soldiers "personal radios" is over for a time at least. Repairmen have been able to get a few batteries for such distribution and for civilian requirements to boot.

A serviceman from this neighborhood may be sticking his neck out, but here's a scheme he's using. He takes all service work in, guaranteeing to repair all "modern sets" within four days, and all old



Courtesy of "Eveready" Batteries

"Weird, isn't it?"



time sets within a full week. Come stormy weather or Indian summer the serviceman gets the work out. The customer is given a ticket with the date that the set will be ready, written on it. Each ticket is in duplicate and is numbered. The original is slapped on the set, duplicate given the customer. Serviceman adopts the rule "no tickie—no washee"—only in this case no stub brings no radio. No itemized bills are made out, because of the time consumed. Serviceman feels that if the customer can't trust her radioman in wartime—when can they be "mutually trustful?"

One big headache is in the servicing of rural customers. Before gas coupons came into vogue it was nothing to whiz out into the ozone for a distance of ten, twenty, even thirty miles. But now—alas and alack—no soap, whether you spell it octane, benzine or gasoline. Some of the boys have made arrangements with feed dealers. The farmer leaves his ailing radio at the feed merchant's when he comes in for a feed and grain order. Or the feed dealers' trucks pick up the faulty receivers as they cruise through the country delivering farm fodder and making service calls on their farm customers.

Turning out to be quite a "pain in the neck," are those customers who bring a radio set in to be repaired. And for full good measure they dump an electric toaster, vacuum cleaner, coffee percolator and a couple of lamps in for repair at one and the same time. Servicemen are partially to blame for in the past they have accepted such merchandise for repair. But now the time element simply won't permit this "extra-curricular activity."

A couple of repairmen have put up signs by their repair benches reading, "We don't service anything but radios. Take your other electric appliances to (name of local electricians)." One half-crazed serviceman, fed up with electric fan servicing for the duration, at last put an ad in the local paper reading, "TAKE YOUR TOASTER, PERCOLATOR, FAN, ETC., TO YOUR NEAREST ELECTRICIAN BUT BRING YOUR RADIO TO US FOR PROMPT, EFFICIENT SERVICING." Aside from the question of time it's far better for the radioman to head strictly his own sphere, which is the restoration to health of sick radios. Let the other members of the electrical family be serviced by electricians pure and simple.

It's getting time to close but here's a thought worth pondering over. Our radio serviceman's organization believes that after the war every repairman should be licensed without further fuss or feathers. Ex-

Do You Need

# RADIO TUBES

NOW?

We have "HARD-TO-GET" and "HARD-TO-FIND" Tubes available and coming in every day. Over 100 different tube numbers. Join our list of preferred customers by writing for those tubes you've been trying to obtain. Tubes for Ray Guns, Phonographs, and all types of Coin-Operated Machines.

All Numbers are subject to Prior Sale!

## NET PRICES

OZ4	1.65	78	.90	12SQ7	1.00
1Q5GT	1.65	6K7G	1.15	12SQ7GT	1.10
2A3	2.00	6N7/GT	1.65	24A	.90
3Q5GT	1.65	6Q7/GT	.90	25L6GT	1.15
5Y3/GT	.75	6SK7	1.05	26	.75
6A7	1.00	6SQ7	1.05	27	.70
6AB	1.35	6SQ7GT	1.15	35/51	1.00
6C5	1.15	6V6GT	1.15	37	.90
6D8	1.00	6Z4/84	1.10	37	.90
6F6	1.15	7A8	1.35	42	.90
6HG/GT	1.15	7B7	1.35	43	1.10
6J5	.95	7F7	1.65	50L6GT	1.10
6J5GT	.95	83	1.35	56	.85
76	.95	84/624	1.10	57	.85
77	.95	12SK7GT	1.10	11726/GT	1.65

We Have Many Other Tube Numbers! Every order subject to prior sale. WPB LIMITATION ORDER No. L265 makes "Supplier's Certificate" mandatory with each order.

ALL SHIPMENTS EXPRESS C.O.D. DO NOT SEND CHECK OR MONEY ORDER. ONLY MAIL ORDER BUSINESS ACCEPTED!

**Chicago Novelty Company, Inc.**

1348 Newport Avenue

Chicago 13, Illinois

aminations should be given by the New York State Board of regents or some serviceman's national group. Otherwise we're in for an influx of so-called radio specialists who had training during the war in the Signal Corps and on the basis of that knowledge intend to become radio servicemen. The youngsters who do know their technical oats can brush up a bit and pass the exams with flying colors. The others will, and deservedly so, fall by the wayside.

Well, that's all for now. You knock 'em dead overseas and I'll try to put a little life in the radios that keep crowding my service center.

As ever,

DAD

## SHRINKING RADIO (Continued from page 199)

As for radio receivers, the demand is for smaller and smaller models and the ultimate is not yet in sight. A complete, self-powered radio set that will be no larger than a dime is not an impossibility and sooner or later it will be produced.

Indeed, the entire radio technique today is headed toward a high precision, quasi-watchmaking trend.

To be sure, we will always have consoles in our living room, but I predict that the future console, if such it may be called, will be a great deal smaller and far more compact than present-day ones. It will be large for only one reason and that is to print and deliver your spot-news radio newspaper in the morning. The latter will be printed while you are still asleep and is ready for you to take out from the delivery chute in front of the set when you get up.

It might be thought that our present radio-phonograph combination requires a large cabinet. This is not necessarily true. The reason is that we will not always have our present phonograph disc records.

A recent important invention shows in which way the phonograph is heading. The record is a cellophane tape. A compact little machine, as small as a portable radio set, uses a record made on that material. The tape is slightly over one inch wide, made into an endless loop 350 feet long. Sixty parallel grooves cut by a special recording needle give eight hours of recording on a single tape, which weighs only a few ounces. It is quite in the realm of possibility that future phonograph records will be made on cellophane or plastic tapes at a fraction of the size, weight and cost of our present records.

IMMEDIATE DELIVERY

FIXED MOULDED BAKELITE

MICA-DIELECTRIC  
CAPACITORS

Manufactured in  
Accordance with  
American War Standards  
to Meet Army and Navy  
Specifications

All R.M.A. or A.S.A. color coded.

A complete stock is ready for immediate shipment of quantities, ranging from 500 to 5,000 of each capacity in regular MICA CAPACITORS in 5%, 10% and 20% tolerance and silvered MICA CAPACITORS in 2%, 5% and 10% tolerances.

Write for price sheets and complete information

ALBERT ROTHENSTEIN

133 Liberty St., New York 6, N. Y.

# FOR SALE HARD-TO-GET ITEMS

All items are brand new, except where indicated. ALL are in PERFECT WORKING ORDER. In many cases, the parts alone total more than the price we are asking. Satisfaction guaranteed or your money back. ORDER FROM THIS PAGE. Use our convenient coupon. Include sufficient extra remittance for parcel post charges, otherwise order is sent express collect. Any excess will be refunded. All C.O.D. shipments require 20% deposit. No C.O.D. shipments on orders for less than \$3.00. If full remittance accompanies order, deduct 2% discount. Send money order, certified check, or new U. S. stamps. No C. O. D.'s to foreign countries.

## THE MAGIC ELECTRIC WELDER

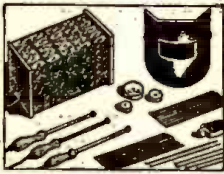

Here is one of the most compact, practical welders we have ever seen. Anyone can use it for shop, farm and home repairs. WELDS, BRAZES, SOLDER, CUTS ALL METALS. ANYONE CAN OPERATE IT. Repairs steel, cast iron, aluminum, brass, copper, bronze, etc. Complete with power unit, flame and metallic arc attachment.

ments. (Really two welders in one). Carbons, fluxes, rods, mask included. Just plug it in any electric outlet. 110 volts AC or DC. For hobbyist or professional. GET IN ON THE GREAT WELDING BOOM. This fine set quickly teaches you welding. Low cost to operate—about 5¢ an hour. COMPLETE SAFETY is insured. No fumes with this outfit. SET COMES COMPLETE—nothing else to buy. Used by the U. S. Navy, American Tel. & Tele. Co., Eastman Kodak Co., Bell Laboratories, etc. BRAND NEW OUTFIT. Guaranteed for one year. Complete simple instructions with each set. ITEM NO. 158 YOUR PRICE \$19.95

## WESTERN ELECTRIC BREAST MIKE

This is a fine light-weight aircraft carbon microphone. It weighs only 1 lb. Mike comes with breastplate mounting and has 2-way swiveling adjustment so that it can be adjusted to any desired position. There are 2 woven straps; one goes around neck, the other around chest. Straps can be snapped on and off quickly by an ingenious arrangement. This excellent mike can be adapted for home broadcasting or private communication systems. By dismantling breastplate, it can be used as desk mike.



Comes complete with 6-foot cord and hard rubber plug. Finished in sherardized plate, non-rustable. THIS IS A BRAND NEW MIKE. IT HAS NEVER BEEN SOLD AT SUCH A LOW PRICE BEFORE. ORIGINAL LIST PRICE \$15.00. SHIPPING BEFORE. ITEM NO. 152 YOUR PRICE \$2.55

## POWERFUL ALL-PURPOSE INDUCTION MOTOR

IDEAL FOR EXPERIMENTERS—101 USES



Sturdily constructed to precision standards, this self-starting reversible shaded pole A.C. induction motor is powerful enough for a number of uses. Some of these are: Automatic Timing Devices, Current Interrupters, Electric Fans, Electric Chimes, Window Displays, Photoelectric Control Devices, Electric Vibrators, Small Grinders, Buffers and Polishers, Miniature Furnaces, Mechanical Models, Sirens, and other applications.

Consumes about 15 watts of power and has a speed of 3,000 r.p.m. When geared down, this sturdy unit will constantly operate an 18-inch turntable loaded with 200 lbs. dead weight—THAT'S POWER! Dimensions 3" high by 2" wide by 1 3/4" deep; has 4 convenient mounting studs; shaft is 1/8" long by 3/16" diameter and runs in ball retaining bearings. Designed for 110-220 volts, 50-60 cycles, A.C. only. ITEM NO. 147 YOUR PRICE \$1.95

## LIMITED QUANTITIES! PROMPT SHIPMENTS!

It's Easy to order—Clip Coupon—Order from This Page—No Catalog Sent. (See Corresponding Ad. Page 244) MAIL TODAY—NOW!

### HUDSON SPECIALTIES CO.

40 West Broadway, Dept. RC-1-44, New York 7, N. Y. I have elected below the number of the items I'm ordering. My full remittance of \$..... (include shipping charges) is enclosed. (NO C.O.D. ORDERS UNLESS ACCOMPANIED WITH A DEPOSIT.)

OR my deposit of \$..... is enclosed (20% required), ship order C.O.D. for balance. NO C.O.D. ORDER FOR LESS THAN \$3.00. (New U. S. stamps, check or money order accepted.)

Circle Item No. wanted 147 152 158

Name .....

Address ..... Please Print Clearly

City ..... State .....

Send remittance by check, stamps or money order; register letter if you send cash or stamps.

## OSCILLATING RADIOS - (Continued from page 221)

tube is shielded. If the shield on the R.F. tube is left off by the owner the set may not work properly.

If the antenna is not stretched out to full length (a small coil antenna about 25 feet in length comes with these midgets) the set may oscillate. The reason is that the R.F. input circuit is not loaded when the antenna is not stretched out. Tightening the R.F. trimmer will reduce the tendency to oscillate under such conditions, but a further contributing cause is that when the input signal is weak, as it is with a short antenna connected to the set, the gain must be advanced—this lowers the bias on the R.F. tube (see Fig. 2) and it is common knowledge that when the gain of a tube is high the circuit is more apt to oscillate than when the gain is low.

### SMALL CAPACITIES ALSO BAD

Oscillation frequently is caused by an open by-pass condenser (or skimpy capacity) in the screen grid circuit of either the R.F. or the detector tube. The ability of such tubes to operate at high gain levels is controlled to a certain extent by the effectiveness of the shielding action of the screen grids which limit the transfer or feedback of energy from the plate circuits to the control grid circuits. If the screen of a tube has a high impedance to ground there will be coupling between the plate circuit and the control grid circuit and oscillation may result. While the set is

amount of signal energy need be fed back in the feedback loop to cause oscillation, as that small amount will be amplified and reamplified until one or more of the a.v.c. controlled tubes breaks into oscillation.

A simple way of checking C11 and C13, of course, is to cut them out of the circuit temporarily, install new condensers and observe the results.

Unshielded tubes or parts also can cause oscillation. When making tube substitutions, bear in mind that in many cases it will be necessary to shield the tube if it is used in an R.F. or I.F. stage of a modern superheterodyne. The mixer tube, however, is not critical. For example, a 6K7-G can be used as a replacement for the 6K7 in some sets, but may need to be shielded. A close fitting type shield, with a single flexible lead soldered to it, may be put over the tube and the lead can be attached to chassis by loosening a screw and wrapping the lead end around the screw or under the head, then tightening up on the screw. The lead may be soldered directly to the chassis in some cases, or to the top of a tuning condenser gang. Where possible, and materials are available, it might be well to go to the trouble of installing a new socket or base shield mount.

Another puzzling form of oscillation, which often appears on the short-wave bands of an all-wave receiver, may be tracked to the electrolytic filter condensers. These may have a much higher impedance

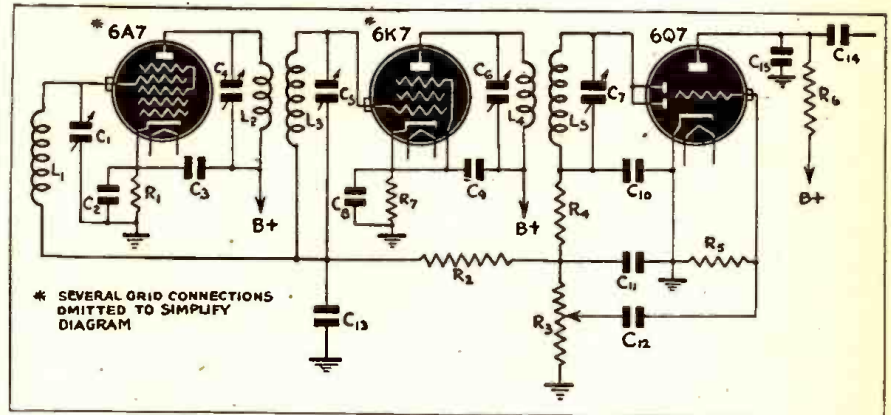

Fig. 3. Part of a superheterodyne receiver, drawn to show the effect of defective components in the a.v.c. circuits on feedback and resultant oscillation. All a.v.c. condensers in a squealing set are suspect, with screen-grid by-passes running them a close second as oscillation sources.

oscillating a simple test to discover open capacitors is to connect a 0.1 mfd. test condenser from each plate return and screen return to ground. In other words, by-pass any condensers you believe to be open, and observe the results. If you find that the oscillation ceases as you apply a test condenser to a particular part of the circuit you know that you need a new condenser there, and can install one to get rid of the trouble.

### OSCILLATION DUE TO THE A.V.C.

Still another form of feedback can occur if a condenser in the a.v.c. system of a modern set opens up. Referring to Fig. 3, if C11 opens up there may be developed an R.F. potential at the I.F. level which will act in series with the grids of the 6A7 and 6K7 tubes, producing feedback and in some cases oscillation, or whistling. If C13 is not in perfect condition this effect is likely to be observed. Only a very small

to high than to low frequencies, so that the set may oscillate on the short-wave but not on the broadcast band. Shunting the last electrolytic condenser in the power pack (the one directly across the high-voltage circuits of the receiver) with a small paper or mica condenser of 0.1 mfd. or even less, will cure this condition.

In individual sets oscillation caused by factors other than those mentioned above may appear. However, most of the commonest kinds are due to the causes just given, and looking for the sources of squeals and oscillation along these lines will result in discovering it in an overwhelming majority of cases.

Cost of plastic sheets, rods and tubes used in the manufacture of electrical and radio equipment as well as many other vital items, will be reduced approximately 10%, according to a recent OPA announcement.

## POPULAR ELECTRONICS

(Continued from page 204)

denser is connected to a 45-volt B battery and when the switch is closed, the condenser will be charged. When the switch is opened and the condenser plate rotated toward minimum capacity it will be noticed that the gold leaves on the electroscope will diverge, indicating that the condenser is discharging.

If two manufactured condensers of the paper variety are at hand, a very interesting experiment may be performed as shown at A and B in Fig. 11. First the condenser and a 40-watt lamp are connected in series with a 110-volt, 60 cycle current supply. Under these conditions the condensers will be unable to pass enough current to light the lamp but connection in parallel, as in B, will correct this condition and light the lamp.

## PHOTOTUBES

(Continued from page 210)

excitation. The high-vacuum type, on the other hand, are quicker-acting, and can follow rapidly fluctuating light intensities. The gas tubes are chiefly useful in relay work, where high sensitivity may be coupled with slower action, while high-vacuum tubes are used in such applications as talking movies, where the phototube must follow faithfully the modulated beam from the sound-strip on the film.

Cesium, Potassium, Rubidium and Sodium are commonly used as cathode materials in commercial types of phototubes. Modifications of these yield a variety of surfaces which can be made to have the correct sensitivity and frequency response for given applications. It might be expected that perfection, from the user's point of view, is not often attainable, and that those surfaces which have an excellent frequency response are deficient in sensitivity. A tube with higher sensitivity, peaking in the wrong part of the spectrum, might be unusable. The wide variety of tubes offered are an attempt to meet all practical types of demand, and to provide an efficient unit for every application.

The characteristics of a number of typical phototubes is given in the table.

## SYLVANIA COMPILES REPLACEMENT CHART

**A** CONCISE pamphlet containing charts and all necessary data on radio tube substitutions has been compiled by Sylvania Electric Products, Inc. engineers as a wartime help to radio servicemen, and is available free of charge from Sylvania distributors or direct from Sylvania at Emporia, Pa.

The pamphlet includes substitution charts for 150 milliamper AC-DC receiver tubes, 300 milliamper AC-DC receiver tubes, and battery tube types, carefully edited to conform with the WPB civilian radio tube program. The pamphlet shows quickly the required receiver modifications necessary for tube substitutions, helps solve difficult problems, and gives first and second choices in possible replacements in an easy-to-use check list. The pamphlet fits standard-size loose-leaf binders.

One of these Sylvania charts (replacements for battery tubes) was printed in the July *Radio-Craft*. Servicemen will find the complete set extremely useful.

## MODEL 625-O-30 D.C. VOLT METER

This is one of today's most popular portables. The new design has a hinged dial cover for added protection; insulated molded case and hand calibrated mirror scale 4.58" in length. Furnished to an accuracy within one-half of 1%. THE TRIPLET ELECTRICAL INSTRUMENT COMPANY, BLUFFTON, O.



## "THE INDUCTANCE AUTHORITY"

By EDWARD M. SHIEPE, B.S., M.E.E.

**THE ONLY BOOK OF ITS KIND IN THE WORLD.** "The Inductance Authority" entirely dispenses with any and all computation for the construction of solenoid coils for tuning with variable or fixed condensers of any capacity, covering from ultra frequencies to the borderline of audio frequencies. All one has to do is to read the charts. Accuracy to 1 per cent may be attained. It is the first time that any system dispensing with calculations and correction factors has been presented.

There are thirty-eight charts, of which thirty-six cover the numbers of turns and inductive results for the various wire sizes used in commercial practice (Nos. 14 to 32), as well as the different types of covering (single silk, cotton-double silk, double cotton and enamel) and diameters of  $\frac{3}{4}$ ,  $\frac{7}{8}$ , 1,  $1\frac{1}{4}$ ,  $1\frac{1}{2}$ ,  $1\frac{3}{4}$ , 2,  $2\frac{1}{4}$ ,  $2\frac{1}{2}$ , 2 $\frac{3}{4}$  and 3 inches.

Each turns chart for a given wire has a separate curve for each of the thirteen form diameters.

The book contains all the necessary information to give the final word on coil construction to service men engaged in replacement work, home experimenters, short-wave enthusiasts, amateurs, engineers, teachers, students, etc.

There are ten pages of textual discussion by Mr. Shiepe, graduate of the Massachusetts Institute of Technology and of the Polytechnic Institute of Brooklyn, in which the considerations for accuracy in attaining inductive values are set forth.

The book has a flexible fiber cover, the page size is 9 x 12 inches and the legibility of all curves (black lines on white field) is excellent.

Order from your dealer or direct—\$2.50

## GOLD SHIELD PRODUCTS

350 Greenwich St., (Dept. R.C. 1), New York City



**AS YOU** might guess, "RADIOCRACY" means: *The Ruling Power of Radio*. A rather fantastic idea, isn't it? . . . but that is nothing compared to the *super-duper* radio and electronic post-war inventions satirically concocted by Hugo Gernsback, in his new Souvenir Booklet.

You'll get a good laugh out of *RADIO-CRACY* which is a hilarious burlesque of your own magazine, *RADIO-CRAFT*, and many of the wild marvels promised by certain visionary members of the electronic fraternity.

We would be happy to send this profusely illustrated booklet to all of our readers, but the edition is limited, due to the current paper shortage, and there are not enough copies to go around. You can get a copy by sending 10c in coin or stamps, to cover postage and handling as long as the supply lasts. Orders will be filled in the sequence of their arrival.

Radio-Craft, 25 West Broadway, New York 7, N. Y.  
Gentlemen: Kindly send me a copy of *RADIOCRACY*.  
I enclose 10c to cover postage and handling costs.

Name .....  
(please print carefully)  
Address .....  
City ..... State .....  
(P. O. District No., if any)

**GEOPHYSICAL  
PROSPECTING  
PRINTS  
(TREASURE  
FINDERS)**

**50¢ EACH  
7 FOR  
\$3.—**

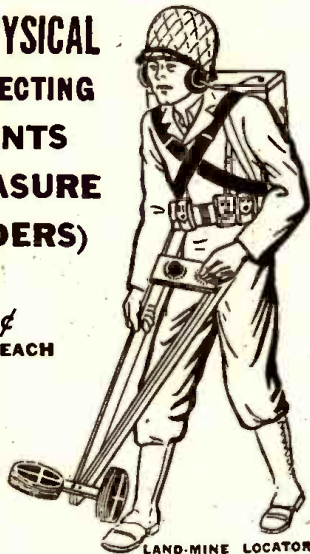

**LAND-MINE LOCATOR**

With any one of the modern geophysical methods described in the Blue-Print patterns, radio outfits and instruments can be constructed to locate metal and ore deposits (prospecting); finding lost or buried treasures; metal war relics; sea and land mines and "duds"; mineral deposits; subterranean water veins; oil deposits (under certain circumstances); buried gas and water pipes; tools or other metallic objects sunken in water, etc., etc.

- Folder No. 1. Radiofactor Pilot. Construction and use of 2 tube transmitter and 3 tube receiver. Reflected wave principle. Visual and aural signals.
- Folder No. 2. Harmonic Frequency Locator. Radiates low frequency wave to receiver. Aural signals.
- Folder No. 3. Beat Note Indicator. 2 oscillators. Visual and aural signals.
- Folder No. 4. Radio Balance Surveyor. Balanced loop principle. Modulated transmitter. Visual and aural signals.
- Folder No. 5. Variable Inductance Monitor. Inductance principle. Aural signals.
- Folder No. 6. Hughes Inductance Balance Explorer. Bridge principle. Aural signals.
- Folder No. 7. Radio-wave Prospector. Balanced loop principle. Very large field of penetration. Aural signals.

Each set of blueprints and instructions enclosed in heavy envelope (9 1/2" x 12 1/2"). Blueprints 22" x 34"; eight-page illustrated 8 1/2" x 11" folder of **50c** instructions and construction data. Add 5c for postage.

The complete set of seven folders **\$3.00**  
Shipping weight 2 lbs. Add 25c for shipping anywhere in U.S.A.)

Send Stamps, Cash or Money Order to

**TECHNIFAX**

RC-1-44

1917 S. STATE ST. CHICAGO, ILL.

**TECHNIFAX** 1917 So. State. Chicago, 16, Ill.

Enclosed herewith \$..... for which mail to address below:

Treasure Finder No. 1, 2, 3, 4, 5, 6, 7.  
Complete set of seven folders.

NAME .....

ADDRESS .....

CITY ..... STATE ..... RC-1-44

**OPPORTUNITY AD-LETS**

Advertisements in this section cost 20 cents a word for each insertion. Name, address and initials must be included at the above rate. Cash should accompany all classified advertisements unless placed by an accredited advertising agency. No advertisement for less than ten words accepted. Ten percent discount six issues, twenty percent for twelve issues. Objectionable or misleading advertisements not accepted. Advertisements for February, 1944, issue must reach us not later than January 18, 1944.

Radio-Craft • 25 W. B'way • New York 7, N. Y.

**LOWEST PRICES. RADIO TUBES, PARTS, FREE** bargain lists. Potter 1314-B McGee, Kansas City, Mo.  
**RADIO SERVICEMEN AND EXPERIMENTERS SEND** for our giant radio catalogue. Save dollars. United Radio Co., (100P) Newark, N. J.

**USED CORRESPONDENCE COURSES AND TECHNICAL** Books Bought, Sold, Rented, Catalog Free. Educational Exchange, Hensger, Alabama.

**Very Old (1900-1920)  
RADIO SETS and PARTS  
WANTED**

Fair prices paid for radio sets and apparatus manufactured from 1900 to 1920. We need only one sample of each model. Write giving complete description and your price. **RADIO-CRAFT**, 25 West Broadway, New York 7, N. Y.

**SUNSPOTS AND RADIO** (Continued from page 205)

measurable quantities as the earth's magnetic activity, and short wave signal recordings.

A sun spot is the localized vortex of a whirlpool of solar gases. Spots appear in groups, on either side of the solar equator. Like tornadoes on earth, they rotate in opposite directions north and south of the solar equator. The leader spot, in the direction of the sun's rotation, is opposite in polarity to the follower spot, or spots. Opposite polarity also exists between spots located on either side of the solar equator. The discovery of sun spot polarity is a contribution to science by the late Dr. George Hale of Mount Wilson Observatory. Polarity is a definite indication of sustained solar circulating currents. Even as radio waves are reflected back to earth by the earth's upper atmosphere, so may sun spot radiations be turned back to the solar disc by the equivalent of a solar ionosphere. On the sun, as on the earth, penetrations will occur, when the generated frequencies become sufficiently high. Such penetrations are abundantly verified by the centuries of terrestrial effects already noted. A typical sun spot group is shown in Fig. 2.

Two long recognized sun spot cycles directly affect short wave radio communication, namely, the twenty-seven day rotational cycle, and the eleven year abundance cycle. The spots, being localized areas on the solar surface, are carried around by rotation of the sun. The twenty-seven day rotational cycle is a measured terrestrial effect. Astronomical observations show the sun to be entirely gaseous, with a rotation period at its equator of about twenty-four days, and at the poles, thirty-two days. The twenty-seven day cycle is the basis for the "radio weather" charts later to be described. The eleven year sun spot abundance cycle has been verified by centuries of observation. During its progress the spots make a solar excursion from about latitude 40° to latitude 5°. Maximum numbers are observed at about solar latitude 16°. The corresponding

reactions upon our radio roof follow this eleven year periodicity with measurable regularity.

One of the most interesting contributions by the late Dr. Hale was his discovery that, magnetically, the sun spot cycle extends for twenty-two years, rather than for eleven years. Sun spot polarities, above and below the solar equator, reverse at the end of the eleven year cycle. It takes twenty-two years to get the spot polarities back to their original starting senses. It is yet to be established that the twenty-two year polarity cycle has significance with respect to sky wave radio communications.

An eruption of the lighter solar gases, such as hydrogen, often precedes the formation of a sun spot group. These sudden solar eruptions are now known to radio men as "flares." They are the source of sudden "fades" on short wave circuits, lasting from two to thirty minutes. A longer and deeper fade occurs when the flare is at the center of the solar disc, than when near the rim. The flare causes daylight "drop-outs" only. Their effects being independent of solar rotation are therefore unpredictable as to recurrence. These sudden fades were first studied and explained by Dr. J. H. Dellinger of the National Bureau of Standards. Fades often serve as harbingers of approaching sun spot barrages. The barrage itself synchronizes quite closely in position and time with the life of a particular sun spot group and its twenty-seven day rotation. The barrage may last for several days, during the spot group passage of the center of the solar disc. Short wave radio circuits are correspondingly upset, in a manner popularly referred to as a "magnetic blanket." The solar prototypes of fades, or "drop-outs," and "magnetic blankets" are flares and sun spots respectively.

The penetrating radiations from a flare reach the earth at light speed, in about eight and one-third minutes. The E and F layers of the ionosphere are pierced. Rarefied air particles in the alto-troposphere are broken

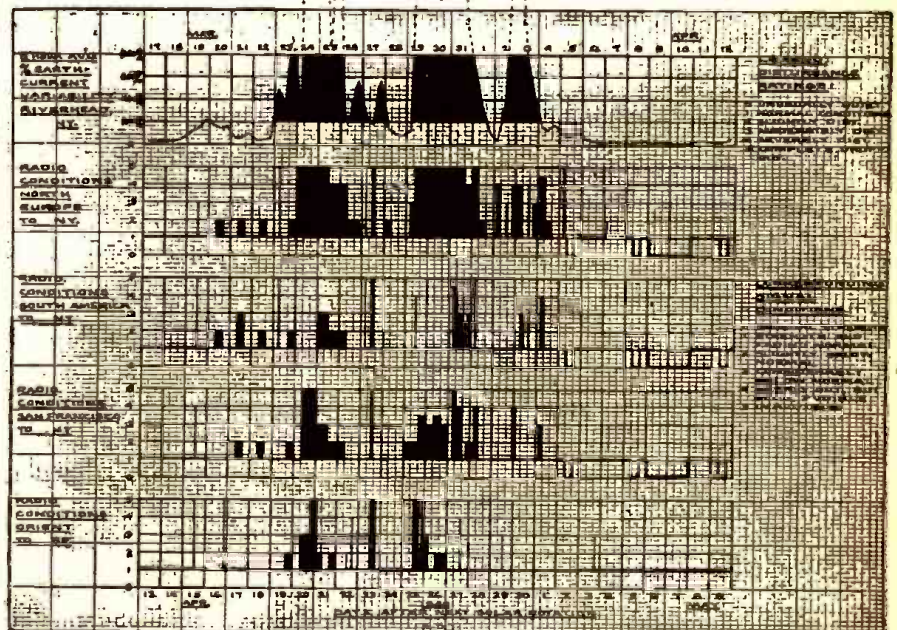

Fig. 4—Earth-current variabilities and world-wide short wave disturbance ratings during the solar rotation period March 17 to April 21, 1940, recorded by R.C.A. Communications at Riverhead, Long Island.

down by the impact, setting up temporary absorption clouds in the normal path of the radio wave. The absorbing screen dissipates, as the flare subsides, in from two to thirty minutes. The radio circuits thereupon return to their preflare condition. The entire process is recorded on the radio circuit as a steep cutoff, and a more gradual return.

Sun spot barrage radiations, on the other hand, are slower, taking one to three days to reach the earth. They persist, causing wide swings in circuit responses, as long as the spot group is near the center of the solar disc. If the spot group survives a solar rotation they will recur. Three or four recurrences are not uncommon.

#### HOW RADIO IS AFFECTED

A radio wave beamed vertically upward is vertically reflected to earth. This is radio echo technique. If the wave frequency is increased, a "critical," or penetrating frequency of the ceiling is reached. No echoes return above the critical frequency. If the wave is beamed at an angle to the ceiling, frequencies above the critical may be reflected. This is the normal process of sky wave radio transmission. A signal in crossing the Atlantic is bounced between ceiling and sea, in two or more hops, depending upon its frequency and the ceiling height. Day and night waves are the result of variations in the E and F layer densities. The limitation of short wave transmission to a well defined band of frequencies is due to absorption at the low end of the band, and ceiling penetration at the other. The sporadic variations are introduced, as above described, by flares and sun spots.

The earth's magnetic poles are also affected by solar radiation activity. The radio roof becomes turbulent during a sun spot barrage. A magnetic modulation results at the earth's magnetic poles. The resulting reaction between the modulated pole, and the ceiling directly above it, makes the polar great circle path temporarily useless, in fact, the polar path may become opaque. The blackout may last for several days following the actual passage of the sun spot, depending upon proximity of the circuit path to the magnetic pole. A temporary dead communications zone is established on the great circle path passing over, or near, the magnetic pole. The effect is graphically shown in Fig. 3.

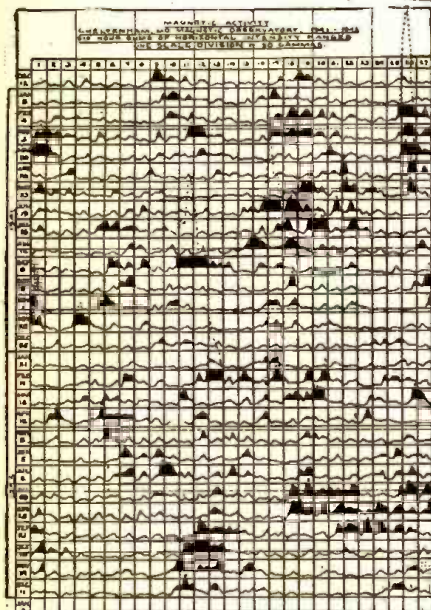

Fig. 5—Magnetic activity from Cheltenham Magnetic Observatory recordings compared to short wave circuit disturbance ratings in the North Atlantic area during the period covering the years 1941-42.

The figure shows the abrupt increase in circuit disturbances that occur during sun spot barrages on circuits passing closer than 30° from the magnetic pole. It is based upon observations of sixteen major sun spot barrages during the years 1939-1940. The geomagnetic latitude mentioned in the figure is the latitude computed on the basis of the north magnetic pole coinciding with latitude 90° N.

#### MEASURING EARTH CURRENTS

Local earth-current activity varies proportionately to terrestrial magnetic activity during a sun spot barrage. Advantage was taken of this fact by the Research Department of R.C.A. Communications to set up a local radio ceiling conditions indicator. At Riverhead, Long Island, New York, a long wave receiving antenna six miles in length—which had no further usefulness as an antenna when short waves superseded long waves for South American service—was connected as a ground loop. A series resistor was connected in this ground loop at the receiving station terminal. Earth-currents circulating through the series resistor produce a voltage drop of corresponding variation, which is continuously recorded. The length of the recorded trace, in an hour, is proportional to the solar activity variations, intercepted at Riverhead, during that hour. The percentage increase of trace length, in any hour, provides a directly comparable measuring unit. This unit has been called "earth-current variability."

The observed relationship between measured earth-current variabilities at Riverhead, Long Island, New York and reported circuit disturbance ratings on Transatlantic, South American, Transcontinental, and Transpacific circuits during two major sun spot barrages, recorded during the solar rotation of March 17 to April 12, 1940 are shown in Fig. 4.

Circuit rating figures, 0 to 5, are reported on all R.C.A. Communications, Inc., circuits for each eight hour watch, on the following basis:—

- 0 Unusually quiet
- 1 Normal conditions
- 2 Slightly disturbed
- 3 Moderately disturbed
- 4 Severely disturbed
- 5 Complete drop-out

(Continued on following page)

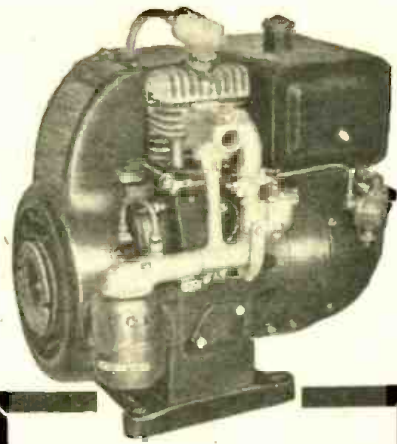

## ELECTRICITY for Any Job Anywhere

ONAN GASOLINE DRIVEN ELECTRIC PLANTS provide electricity for communications work in locations where it is not otherwise available, and for emergency and standby service. Thousands of these sturdy, reliable plants are doing a winning job on all fighting fronts, in communications and other war tasks.

50 to 800 cycles, 110 to 660 volts, A.C.—6 to 4000 volts, D.C. Also dual A.C. and D.C. output types. Engines are air or water cooled.

Your inquiry regarding present or post-war needs will receive prompt attention.

# ONAN

ELECTRIC PLANTS



Awarded to each of the four manufacturing plants of D. W. Onan & Sons.

**D. W. ONAN & SONS**

729 Royalston Ave.

Minneapolis, Minn.

## Short-Cut Mathematics COMBINED WITH Practical Mechanics Simplified

NEW 2-in-1 reading course! Now you can learn the speedy, simplified system of calculation used by draftsmen, engineers, accountants, "master minds" on the stage. Learn easy way to multiply 4 figures by 4 figures without using old-fashioned multiplication; add long columns of figures this lightning short-cut method. Learn horsepower, slide rule, micrometer, logarithms, wood measure, puzzles, etc., etc. Large illustrated volume complete with answers, only \$1 postpaid. Satisfaction or refund. Amaze friends with your magic-like mental powers.

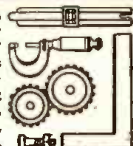

**FREE** Complete details... mail coupon TODAY!

NELSON CO., 321 So. Wabash, Dept. A-310, Chicago

Please send free details about "Short-Cut Mathematics and Practical Mechanics Simplified." No obligation.

Name \_\_\_\_\_  
Address \_\_\_\_\_

# FOR SALE

## HARD-TO-GET ITEMS

All items are brand new, except where indicated. ALL are in PERFECT ORDER. In many cases, the parts alone total more than the price we are asking. Satisfaction guaranteed or your money back. ORDER FROM THIS ad. Our convenient coupon includes sufficient extra remittance for parcel post charges, otherwise order is sent express collect. Any excess will be refunded. All C.O.D. shipments require 20% deposit. No C.O.D. shipments on orders for less than \$3.00. If full remittance accompanies order, deduct 2% discount. Send money order, certified check, or new U. S. stamps. No C. O. D.'s to foreign countries.

### ULTRA MAGNET

LIFTS MORE THAN 20 TIMES ITS OWN WEIGHT

LITTLE GIANT MAGNET

Lifts 5 lbs. easily. Weighs 4 oz. Made of ALNICO new high-magnetic steel. Complete with keeper. World's most powerful magnet ever made. The experimenter and hobbyist will find hundreds of excellent uses for this high-quality permanent magnet. Measures 1 3/4" x 1 1/2" x 3/8" lbs.

ITEM NO. 159 YOUR PRICE \$1.25



### VARIABLE SPEED UNIVERSAL MOTOR

For 110 Volts. A.C. or D.C. All Nickel Plate



Edison Dictaphone motor 1/50 H.P. Used but in excellent condition. For buffing, polishing, drilling, sawing, runs phonographs, fans, models, blowers, lathes, etc. Special control permits variable speeds up to 1500 r.p.m. 5/16" shaft extends from both sides of motor. Cast iron base has 3 screw mounting holes. Height 4 1/2"; length 7 1/2"; width 5 1/2". Shaft is 1 3/4" long on one side. Shpd. Wt. 8 lbs.

ITEM NO. 157 YOUR PRICE \$3.45

### POWER ADJUSTABLE RHEOSTAT

Here is an excellent rheostat used especially to regulate speeds of small motors, such as our Handy Workshop Outfit. This rheostat can be used in connection with motors up to 1/20 h.p.



This fine rheostat is wire-wound on porcelain insulation. The black enamel steel casing is perforated for ventilation. Adjustable speed of motor easily and smoothly. Size 5"x2 3/4" overall. Shpd. Wt. 2 lbs.

ITEM NO. 153 YOUR PRICE \$1.45

### AMAZING BLACK LIGHT!

Powerful 250-Watt Ultra-Violet Source

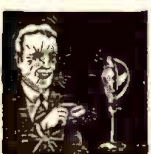

The best and most practical source of ultra-violet light for general experimental and entertainment use. Makes all fluorescent substances brilliantly luminescent. No transformers of any kind needed. Fits any standard lamp socket. Made with special filter glass permitting only ultra-violet rays to come through. Brings out beautiful opalescent hues in various types of minerals. Swell for amateur scientists. Plays, etc.; to obtain unique lighting effects. Shpd. Wt. 1 lb.

ITEM NO. 87 YOUR PRICE \$2.45

### WATTHOUR METER

Completely overhauled and ready for immediate service.

Designed for regular 110-volt, 60 cycle 2-wire A.C. circuit. Servicemen use it in their shops to check current consumption of sets, soldering irons, etc. Keeps costs down. If disconnected, the parts alone would bring the price. The elaborate rear train could be used as a counter on machines of various kinds. Simple to install; 2 wires from the line and 2 wires to the load. Sturdily constructed in heavy metal case. 3 1/2" high, 6 1/4" wide, 4" deep. Westinghouse, G. E. or Ft. Wayne makes. Shpd. Wt. 14 lbs.



ITEM NO. 33 YOUR PRICE \$4.95

### LIMITED QUANTITIES! PROMPT SHIPMENTS!

It's Easy to order—Clip Coupon—Order from This Page—No Catalog Sent. MAIL TODAY—NOW!

(See Corresponding Ad. Page 240)

### HUDSON SPECIALTIES CO.

40 West Broadway, Dept. RC-1-44, New York 7, N. Y.

I have circled below the numbers of the items I'm ordering. My full remittance of \$... (include shipping charges) is enclosed (NO C.O.D. ORDERS UNLESS ACCOMPANIED WITH A DEPOSIT.) or my deposit of \$... is enclosed (20% remittance ship order C.O.D. for balance. NO C.O.D. ORDER FOR LESS THAN \$3.00. (New U. S. stamps, check or money order accepted.) Circle item No. wanted: 33 87 153 157 159

Name .....

Address ..... Please Print Clearly

City ..... State .....

Send remittance by check, stamps or money order; register letter if you send cash or stamps.

## SUNSPOTS AND RADIO (Continued from previous page)

Latitude effects are quite apparent in the figure. Great circle paths passing near the north magnetic pole show maximum circuit interruptions, equatorial circuit paths lowest interruptions. A flare type of fade may be observed on March 19, to have preceded the main barrage on March 24th.

### RADIO "WEATHER MAPS"

It has been stated earlier in this paper that sun spot barrages may be studied indirectly by their observed effects upon terrestrial magnetism, and short wave transmission. If these effects are continuously recorded, and charted in twenty-seven day sequences of solar rotations, the resulting chart is in effect a progressive scanning of the circumference of the sun. If there is simultaneously charted, on the same basis, the observed circuit disturbance ratings over the North Atlantic for example a parallel comparison of equivalent solar activity, and short wave circuit disturbance may be obtained. Such a parallel comparison of magnetic activity as derived from analysis of magnetograms from Cheltenham Magnetic Observatory, and North Atlantic Circuit Disturbance Ratings for the years 1941 and 1942 is shown in Fig. 5.

Black areas on the Cheltenham Magnetic Activity Chart are those whose deflection ranges are above a limiting value sufficient to cause radio circuit disturbance. Black areas on the North Atlantic Circuit Disturbance Rating Chart represent subnormal

circuit conditions, on the 0 to 5 scale basis, previously mentioned. A full black area of 5, for all three watches of any particular day would indicate that the circuit was completely dead for the duration indicated.

Examination of these charts reveals that the start of a magnetic disturbance is closely synchronized with the onset of the radio circuit disturbance. The duration of the North Atlantic circuit disturbance, on the other hand, may persist some four or five days after the magnetic disturbance has subsided. The effect may be likened to the ocean ground swell that persists after a severe storm at sea.

These charts are in effect "Radio Weather" maps. They plot the moods of successive areas on the sun by their measured effects upon our radio roof. If a particular area on the sun holds a sun spot group, the resulting sun spot barrage will be indicated on the chart in relative intensity and duration. The life of the sun spot group may be quite accurately interpolated by its repeated effects during each succeeding rotation of the sun. Concurrent effects of aurora and sky wave transmission may also be studied, and forecast, by such systematic chartings.

The developing knowledge of that basic element, the free ion, is bringing together the astronomer, the physicist, and the radio man. It may be merely a step in a vast integration process, which tends to blend scientific effort into one indivisible whole.

## THE LISTENING POST (Continued from page 224)

Mc.	Call	Location and Schedule	Mc.	Call	Location and Schedule
7.250	KGEI	SAN FRANCISCO, CALIF.; N.E.I.—Orient beam, 1 am to 1:05 pm.	9.295	COCX	HAVANA, CUBA; daytimes; CIUDAD TRUJILLO, DOMINICAN REPUBLIC; Sunday afternoons.
7.260	GSU	LONDON, ENGLAND; North American beam, 5:15 to midnight.	9.35	COBC	HAVANA, CUBA; afternoons.
7.290	DJX	BERLIN, GERMANY; variable times; North American beam.	9.437	COCH	HAVANA, CUBA; afternoons.
7.295	YSO	SAN SALVADOR, EL SALVADOR; "Voice of Democracy"; nightly at 7:55 pm.	9.455	GRU	LONDON, England; Near East, Africa and Gibraltar beam, about noon.
7.31	ZRO19	ROME, ITALY; off since September 8th, 1943.	9.465	TAP	ANKARA, TURKEY.
7.440	—	LONDON, ENGLAND; North American beam, 10:35 pm to midnight.	9.490	KRCA	SAN FRANCISCO, CALIF.; 1 am to 1 pm, Oriental beam.
7.565	WKLI	NEW YORK CITY; North African beam, 8:15 pm to 5 am.	9.490	WC8X	NEW YORK CITY; Latin American beam, 5 to 11:30 pm.
7.565	KWY	SAN FRANCISCO, CALIF.; 8:30 to 10:30 am daily, Sundays, 9:30 to 10:30 am.	9.50	XEWW	MEXICO CITY, MEXICO; evening transmissions.
7.575	WRUA	BOSTON, MASS.; North African beam, 4:45 to 7:15 pm; 7:30 to 11:45 pm.	9.505	JLG2	TOKYO, JAPAN; North American beam, 11 am to 2:40 pm; 11 pm to 4 am.
7.805	WRUL	BOSTON, MASS.; North African beam, 2:15 to 5:45 am.	9.51	GSV	LONDON, ENGLAND; Near East, Africa and Gibraltar beam, about noon.
7.820	WKRD	NEW YORK CITY; European beam, 4:45 pm to 4:45 am.	9.520	—	G E N E V A, SWITZERLAND; not heard recently.
7.950	—	ALICANTE, SPAIN; off at 6 pm daily.	9.52	DZD	BERLIN, GERMANY; not heard recently.
8.000	—	ATHENS, GREECE; heard 3 to 6 pm daily.	9.52	DXL13	PARIS, FRANCE; relays Berlin to North America, 5:30 pm to midnight.
8.030	FXE	BEIRUT-LEBANON; 6:30 to 6:45 pm; irregular.	9.523	ZRH	JOHANNESBURG, SOUTH AFRICA; not heard recently.
8.220	—	DAKAR, SENEGAL (French West Africa); off at 5:04 pm.	9.530	WGEA	SCHENECTADY, NEW YORK; 3:30 to 6 am, European beam.
8.484	XPSA	KWEIYANG, CHINA; 7:30 am to 12 noon.	9.530	WGEO	SCHENECTADY, NEW YORK; East South American beam, 5:30 pm to midnight; European beam, 3:15 to 5:15 pm.
8.634	COJK	CAMAGUEY, CUBA; daytimes.	9.535	SBU	STOCKHOLM, SWEDEN; European beam, 5:15 to 5:50 pm; North American beam, 9 to 10 pm.
8.70	COCO	HAVANA, CUBA; daytimes.	9.535	JZI	TOKYO, JAPAN; 11 am to 12:30 pm.
8.83	COCO	HAVANA, CUBA; daytimes.	9.54	MTCY	HSINGKING, MANCHUKUO; 9 to 11 am.
8.930	KESZ	SAN FRANCISCO, CALIF.; 6:15 am to 1 pm; Oriental beam.	9.54	VLG2	MELBOURNE, AUSTRALIA; Eastern North American beam, (English) 11 to 11:45 am.
8.955	COKG	SANTIAGO, CUBA; heard at 6:30 pm.	9.562	OAX4T	LIMA, PERU; "Radio Nacional"; 2 to 8 pm daily.
8.960	AFHQ	ALLIED HEADQUARTERS, NORTH AFRICA; daily, early evenings.	9.565	JRAK	PARAO, PALAU GROUP; 7 to 9:30 pm.
9.03	COBZ	HAVANA, CUBA; "Radio Sala"; heard evenings; relays CMBZ.	9.57	KWIX	SAN FRANCISCO, CALIF.; South American beam, 8 pm to 12:45 am; Oriental beam, 1 to 2:45 am; 7:30 am to 4:45 pm.
9.125	HAT4	BUDAPEST, HUNGARY; 9:15 to 9:30 pm; 10:15 to 10:30 pm.	9.570	KWID	SAN FRANCISCO, CALIF.; Australian beam, 3 to 6:15 am.
9.185	COCQ	HAVANA, CUBA; afternoons.			
9.250	COBQ	HAVANA, CUBA; relays CMCQ, evenings.			
9.255	—	BUCHAREST, ROUMANIA; 4 to 5 pm; news (English) 4:50 pm.			
9.26	GSU	LONDON, ENGLAND; Near East, Africa, and Gibraltar beam, about noon.			

# AMPLIFIER MANUAL

By **A. C. SHANEY**  
Chief Engineer, Amplifier Co. of America

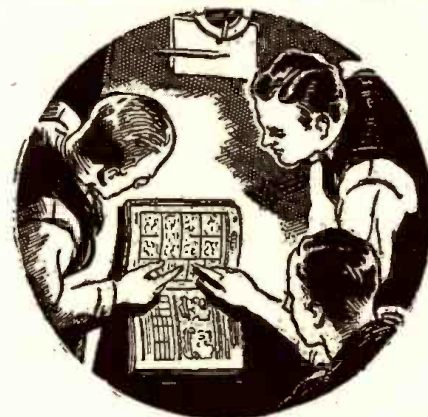

## For the Layman, Serviceman Recordist and Engineer

Regardless of whether you are interested in the finest type of phonograph reproduction, high fidelity recording, sound-on-film applications, FM or AM programs, you will find invaluable information in this practical handbook. Written by the leading exponent of direct-coupled amplifiers who has spent more than 10 years improving and perfecting the famous Loftin-White circuit.

### Explains the theory and practical application of:

- Variable Speed Non-Overloading Push-Pull Expansion
- Non-Frequency Discriminating Scratch Suppression
- Push-Pull Balanced Direct-Coupled Amplification
- Push-Pull High-Frequency Equalization
- Push-Pull Low-Frequency Equalization
- Push-Pull Volume Compression
- Automatic Volume Limitation
- Automatic Volume Control
- Calibrated V. U. Indicator
- Audio Spectrum Control
- Remote Control

If you are interested in the latest audio developments, you can't afford to be without this complete compilation of authentic articles on Direct-Coupled Amplifiers. 32 pages 8 1/2 x 11". Over 100 diagrams and illustrations.

Priced to Cover Cost of **25c**  
Printing and Mailing

Send Stamps or Coin

## AMPLIFIER CO. of AMERICA

396 BROADWAY

NEW YORK, N. Y.

## Headset Headquarters



Scientifically Built Heavy bar magnets greatly increase their efficiency.

Our Headphones are used by the United States, Canadian New Zealand and South African Governments as well as other Governments not directly in the war. Folder R-1 illustrates rugged, unusually sensitive, dependable Cannon - Ball Headsets.

Write C. F. CANNON COMPANY  
SPRINGWATER, N. Y.

## RADIO AND ELECTRONIC DEVICES

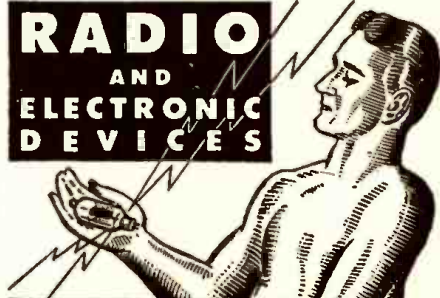

## BURSTEIN-APPLEBEE CO.

1012-14 McGee St. Kansas City, Mo.

Mc.	Call	Location and Schedule	Mc.	Call	Location and Schedule
9.570	WRUS	BOSTON, MASS.; North Africa, 4:45 to 7:15 pm.	10.005	—	VOICE OF FREE ARABS; Sundays, 2:15 to 2:34 pm; 3:15 to 3:35 pm.
9.580	GSC	LONDON, ENGLAND; North American beam, 5:15 to 12:45 am.	10.010	—	"BULGARIAN FREEDOM STATION"; 2:15 to 2:28 pm.
9.58	VLG	MELBOURNE, AUSTRALIA; not heard recently.	10.050	XBHX	MEXICO CITY, MEXICO; 8 am to 8 pm daily.
9.590	WCDA	NEW YORK CITY; European beam, 6 to 7:30 am.	10.250	—	? STATION: 7:45 to 8:15 pm; used for theme "God Bless America."
9.59	—	"VOICE OF FREE INDIA"; not heard recently.	10.540	DZD	BERLIN, GERMANY; 5:50 to 8 pm to North America.
9.59	—	"NATIONAL CONGRESS RADIO"; not heard recently.	10.620	KES2	SAN FRANCISCO, CALIF.; 1 to 6 am, N.E.I.-Oriental beam.
9.595	—	ATHLONE, IRELAND; not heard recently.	10.75	—	RIO DE JANEIRO, BRAZIL; carries PRL8 program.
9.608	ZRL	CAPE TOWN, SOUTH AFRICA; fades out in eastern U. S. about 10:45 am.	10.840	KWV	SAN FRANCISCO, CALIF.; Australian beam, 2 to 4:45 am; South American beam, 5 to 7 am.
9.160	ZYCB	RIO DE JANEIRO; 6 to 10 pm.	11.000	PLP	BANDEONG, JAVA.
9.615	TIPG	SAN JOSE, COSTA RICA; "La Voz de la Victor"; heard mornings and evenings.	11.040	—	LISBON, PORTUGAL; Brazilian beam, 6:45 to 8:45 pm.
9.620	OPL	LEOPOLDVILLE, BELGIAN CONGO; after midnight; used by "Radio National Belge."	11.145	WRUA	BOSTON, MASS.; North African beam, 6 to 7:30 am; 7:45 am to 4:30 pm.
9.62	—	VICHY, FRANCE; North American beam, 8:15 pm.	11.37	—	CROATIAN FREEDOM STATION; not heard recently.
9.630	2RO3	ROME, ITALY; off since September 8th, 1943.	11.470	—	"VOICE OF FREE INDIA"; not heard recently.
9.64	LRI	BUENOS AIRES, ARGENTINA; "Radio Belgrano"; evenings.	11.470	—	"NATIONAL CONGRESS RADIO" (INDIA) not heard recently.
9.650	WCDA	NEW YORK CITY; European beam, 3:30 to 7 pm.	11.470	—	"AZAD MOSLEM RADIO"; not heard recently.
9.660	LRX	VATICAN CITY; heard 7 pm Sundays calling Venezuela. South America; opens program with phrase "Laudator Jesus Christus."	11.6	—	ROUMANIAN FREEDOM STATION; 1:45 to 1:55 pm; 4:15 to 4:25 pm.
9.660	LRX	BUENOS AIRES, ARGENTINA; "Radio El Mundo"; evenings.	11.616	COK	HAVANA, CUBA; "The Voice of Liberty"; noon to midnight.
9.670	WRCA	NEW YORK CITY; Brazilian beam, 8 to 11:30 pm.	11.633	—	"HUNGARIAN NATIONS RADIO"; 1:15 to 1:27 pm.
9.670	WNBI	NEW YORK CITY; European beam, 12:15 to 2 am; 6 to 7:30 am; 3:45 to 5:15 pm.	11.65	COCX	HAVANA, CUBA.
9.685	TGWA	GUATEMALA CITY, GUATEMALA; 9:55 pm to 12:45 am.	11.675	OPL	LEOPOLDVILLE, BELGIAN CONGO; 1 to 6:15 pm.
9.690	GRX	LONDON, ENGLAND; North American beam, 10:45 pm to 12:45 am; now used by the Dutch government in exile.	11.680	GRG	LONDON, ENGLAND; 11:30 am to 5 pm, Near East, Africa and Gibraltar beam.
9.69	LRAI	BUENOS AIRES, ARGENTINA; Fridays only, 5 to 5:30 pm; "Radio Del Estado."	11.7	HP5A	PANAMA CITY, PANAMA; news (English) 7:15 pm.
9.700	WRUW	BOSTON, MASS.; Caribbean beam, 6:15 to 7:15 pm; European beam, 2:45 to 5:55 pm.	11.7	GBW	LONDON, ENGLAND; Near East, Africa and Gibraltar beam, about noon.
9.700	WRUS	BOSTON, MASS.; Mexican beam, 7:30 pm to 2 am; North African beam, 6 to 7:30 am.	11.705	CBFY	VERCHERES, CANADA; 7:30 am to 11:30 pm.
9.720	PRL7	RIO DE JANEIRO, BRAZIL; "Radio Nacional" 6 to 9:55 pm.	11.720	CJRX	WINNIPEG, CANADA; noon to 4:30 pm.
9.724	CSW	LISBON, PORTUGAL; African beam, 3 to 6:30 pm.	11.72	PRL8	RIO DE JANEIRO, BRAZIL; "Radio Nacional" nightly beamed to North America, 10 to 11 pm; off Sundays.
9.750	—	ROME, ITALY; off since September 8th, 1943.	11.725	JWV3	TOKYO, JAPAN; 9 am to 2:40 pm.
9.740	—	LISBON, PORTUGAL; North American beam, 9 to 10 pm.	11.730	WRUL	BOSTON, MASS.; Caribbean beam, 6:15 to 7:15 am; Central American beam, 7:30 pm to 2 am; European beam, 2:30 to 5:55 pm.
9.750	WKLJ	NEW YORK CITY; North African beam, 5:15 to 7 am; 3:30 to 8 pm.	11.730	WRUW	BOSTON, MASS.; European beam, 8 to 10 am.
9.755	—	"RADIO INCONNU"; 3 to 3:11 1/2 pm; chimes or bells.	11.74	COCX	HAVANA, CUBA; afternoon transmissions.
9.760	—	"DEUTSCHER KURZ WELLEN SENKER ATLANTIC"; 1:30 to 2 pm Sunday; 3:30 to 3:58 pm; 4:30 to 4:58 pm.	11.750	GSD	LONDON ENGLAND.
9.765	OPL	LEOPOLDVILLE, BELGIAN CONGO; after midnight; used by "Radio National Belge."	11.77	DJD	BERLIN, GERMANY; North American beam, evening transmissions.
9.785	OPL	LEOPOLDVILLE, BELGIAN CONGO; 8:15 to 8:48 pm; also Sunday afternoons.	11.775	—	FRENCH INDO CHINA; "Radio Saigon"; 10 to 11:30 am.
9.825	GRH	LONDON, ENGLAND; North African beam, 5:15 pm to 12:45 am.	11.775	MTCY	HSINKING, MANCHURIA; 1:30 to 3 am.
9.830	GRX	LONDON, ENGLAND.	11.78	GVU	LONDON, ENGLAND; North American beam, 6:30 to 7 pm.
9.835	—	"HUNGARIAN NATIONS RADIO"; 3:15 to 3:27 pm.	11.790	HP5G	PANAMA CITY, PANAMA; 9:45 pm to ?
9.845	—	"RATIONS NAZIONALE FASCISTI"; 3:30 to 5:57 pm.	11.79	KGEI	SAN FRANCISCO CALIF.; 5 pm to 12:45 am; South American beam.
9.860	—	MOSCOW, U.S.S.R.; heard evenings.	11.800	H13X	TRUJILLO, DOMINICAN REPUBLIC; testing at 12:15 pm.
9.86	EAQ	MADRID, SPAIN; 7 to 7:15 pm in English; later in Spanish.	11.80	JZJ	TOKYO, JAPAN; 11 pm to 4 am.
9.870	—	"PRAHEVA"; 5 to 5:07 1/2 pm; opens with train whistle and closes with three train whistles; 7 language.	11.805	COBH	HAVANA, CUBA; heard at 7:40 pm.
9.890	—	? FREEDOM STATION; 3:15 to 3:28 pm.	11.805	COGF	HAVANA, CUBA; afternoon transmissions.
9.897	WKRD	NEW YORK CITY; European beam, 5 to 6:45 am.	11.81	2RO22	ROME, ITALY; off since September 8th, 1943.
9.897	KROJ	LOS ANGELES, CALIF.; N.E.I.-Orient beam, 10:15 pm to 3:45 am; 11:15 am to 2:15; Australian beam, 4 to 9 am.	11.830	WCRC	NEW YORK CITY; Latin American beam, 5:30 pm to midnight; European beam, 7 am to 5:15 pm.
9.897	WKRX	NEW YORK CITY; North European beam, 4 to 8:45 pm.	11.840	COBH	HAVANA, CUBA; mornings, afternoons, and evenings; relays CMCX and CMCX.
9.935	—	"RADIO MEDITERRANEAN"; heard Sundays, 1:58 to 2:30 pm.	11.847	WGEA	SCHENECTADY, NEW YORK; European beam, 6:15 am to 4:45 pm; Brazilian beam, 5 to 8:15 pm.
9.958	HCBJ	QUITO, ECUADOR; afternoons.	11.86	GSE	LONDON, ENGLAND; Near East, Africa, and Gibraltar beam, about noon.
10,000	WWV	BELTSVILLE, MARYLAND; on the hour every hour; frequency test signals.	11.870	WBOS	BOSTON, MASS.; European beam, 5:45 to 7 am; 3:15 to 5:15 pm.
			11.870	WNBI	NEW YORK CITY; East South America beam, 7 pm to midnight; Sundays only; 7:45 pm to midnight.
			11.88	LRR	ROSARIO, ARGENTINA; heard evenings; CBS news in Spanish, 6:30 to 6:45 pm.

(Continued on following page)

# TECHNICAL BULLETINS

Technical bulletins give reliable information in easy-to-follow form, and save valuable time otherwise spent in laborious reading of numerous books. Every subject is treated briefly and concisely, yet completely. No complicated mathematics, chemistry, electricity, or theory. Each bulletin is written in simple language.

Each Bulletin consists of a set of large sheets, assembled in one packet, size 9 x 14 1/2"; weight 1/4 lb. Numerous illustrations, diagrams, charts to supplement text.

PRICE \$1.00 EACH POSTPAID  
ORDER BY NUMBER

- D-111—DESIGNING AND BUILDING TRANSFORMERS
- D-112—DESIGNING ELECTRO-MAGNETS
- D-113—HOW TO DESIGN SOLENOIDS AND PLUNGER MAGNETS
- D-101—USING NICHROMERESISTANCE WIRE
- D-106—REWINDING ELECTRIC MOTORS
- D-144—ALTERNATING CURRENT CONTROLLED WITH EASILY MADE CHOKE COILS
- D-148—DESIGNING AND USING ELECTRIC RELAYS
- D-127—SMALL ELECTRIC LIGHT PLANTS
- D-184—ELECTRICAL EXPERIMENTS WITH SIMPLE MATERIALS
- D-131—MODEL MAKERS & INVENTORS GUIDE TO REMOTE-CONTROL SWITCHING
- D-137—ELECTRICAL METERS EASILY BUILT
- D-136—SMALL A.C. ARC WELDER CONSTRUCTION AND USE

Send Stamps, Cash or Money Order

# TECHNIFAX

1917 S. STATE ST. RC-1-44 CHICAGO, 16, ILL.

DEPT. RC-1-44  
TECHNIFAX 1917 So. State, Chicago, 16, Ill.

Enclosed find \$..... for which please send me postpaid the following Technical Bulletins:

Nos. ....

Name .....

Street and Number .....

City and State .....

## LEARN CODE the way you'll be using it by SOUND



The best way to learn to read code is by listening to code. The best way to learn to send code is by hearing your own sending repeated back to you. With the new All-Electric Master Teleplex Code Teaching Machine, you learn code the natural, easy, fascinating way. Only instrument ever produced which records your sending in visible dots and dashes—then SENDS BACK your own key work at any speed you desire. There are NO PERFORATIONS—NO INK. Far superior to anything ever developed—a marvel of simplicity. That's why practically every school teaching code uses TELEPLEX. We furnish complete course, including the All-Electric Master Teleplex. Give you personal instruction with a MONEY BACK GUARANTEE—all at a surprisingly low cost. Write today for FREE catalog T-1. No obligations.

107 HUDSON ST. JERSEY CITY, N. J.

USED Correspondence Courses

Complete HOME-STUDY Courses and self-instruction books, lightly used. Rent, sold, exchanged. All subjects. Satisfaction guaranteed. Cash paid for used courses. Full details & 64-page illustrated bargain catalog free. Write now.

NELSON CO., 321 So. Wabash Ave., Dept. 216, Chicago, Ill.

Mc.	Call	Location and Schedule	Mc.	Call	Location and Schedule
11.890	CXAIO	MONTEVIDEO, URUGUAY; "Radio Electrica de Montevideo": heard evenings, about 7:30 pm; relays CX6.	15.210	WBOS	BOSTON, MASS.; European beam, 7:15 to 9:30 am; 10:45 am to 3 pm; (5:15 pm on Saturdays); North European beam, 9:45 to 10:30 am; East South American beam, 5:30 to 8:15 pm.
11.893	WRCA	NEW YORK CITY; European beam, 5 to 8:45 am; 3 to 4:45 pm.	15.225	JTL3	TOKYO, JAPAN; 6:15 to 8:15 pm; news in English at 6:20 and 7:20 pm.
11.895	CXAIO	MONTEVIDEO, URUGUAY; evenings.	15.240	TPCS	VICHY, FRANCE; 11:15 am to 1:30 pm.
11.900	XGOY	CHUNGKING, CHINA; Asia-Australia-New Zealand beam, 6 to 6:30 am; East Russia beam, 6:30 to 7 am; Japan beam, 7 to 7:30 am; Europe beam, 11:35 am to 12:30 pm.	15.250	WLWK	CINCINNATI, OHIO; European beam, 8:30 am to 5:15 pm; West South American beam, 5:30 to 8:15 pm.
11.900	CXAIO	MONTEVIDEO, URUGUAY; evenings.	15.270	WC8X	NEW YORK CITY; European beam, 7 am to 4:45 pm.
11.910	ZRO	ROME, ITALY; off since September 8th, 1943.	15.29	KWID	SAN FRANCISCO, CALIF.; Oriental beam, 1 to 2:15 am; South American beam, 1 to 9 pm.
11.970	FZI	BRAZZAVILLE, FRENCH EQUATORIAL AFRICA; "Radio Brazzaville": 4:45 to 5 pm; 3:45 to 4 pm; 7:45 to 8 pm; other times.	15.300	ZRO6	ROME, ITALY; off since September 8th, 1943.
12.000	—	LISBON, PORTUGAL; Oriental beam, 8 to 10 am.	15.31	GSP	LONDON, ENGLAND; 11:30 am to 3 pm.
12.060	FFZ	SHANGHAI, CHINA; heard at 8 am.	15.320	JFY	TAIHKU, JAPAN.
12.115	ZNR	ADEN, ARABIA; off at 1:16 pm.	15.345	FGA	DAKAR, SENEGAL (AFRICA); 2:45 to 7 pm.
12.135	TFJ	ICELAND; heard early mornings, irregular.	15.350	WRUL	BOSTON, MASS.; European beam, 10 am to 2:15 pm.
12.445	HCJB	QUITO, ECUADOR; "Voice of the Andes": 5 to 11 pm, except Monday; in English at 10 pm.	15.355	KWU	SAN FRANCISCO, CALIF.; Australian beam, 4:30 to 6:15 pm daily; Sundays, 4:45 to 6:15 pm; off Wednesday; N.E.I. beam, 7:45 to 9:30 pm; off Wednesdays; South American beam, 11 am to 2 pm.
12.967	WKRJ	NEW YORK CITY; North African beam, 12:45 to 4:30 pm.	15.370	ZYC8	RIO DE JANEIRO, BRAZIL; 10 am to noon; evenings.
12.967	WKRX	NEW YORK CITY; North African beam, 6 to 8 am.	15.410	RY96	MOSCOW, U.S.S.R.
14.460	DZH	BERLIN, GERMANY; 10 to 10:45 am.	15.45	GRD	LONDON, ENGLAND; Near East, Africa and Gibraltar beam, about noon.
14.480	—	EL SALVADOR; 1 pm to ?	15.465	ZRO24	ROME, ITALY; off since September 8th, 1943.
15.105	JLG4	TOKYO, JAPAN; 2 to 4 am, heard some evenings.	15.80	LRF3	ARGENTINA; late afternoons.
15.110	GSP	LONDON, ENGLAND.	16.025	AFHQ	ALLIED HEADQUARTERS, NORTH AFRICA; daily 9:18 to 11:30 am (call G8C and G8I).
15.11	DJL	BERLIN, GERMANY.	17.72	LRA5	BUENOS AIRES, ARGENTINA; "Radio Del Estado"; Fridays, 5 to 5:30 pm.
15.130	WRUS	MOSCOW, U.S.S.R.; 9:15 pm and 11:15 pm; 5:15 to 5:40 pm.	17.750	WRUW	BOSTON, MASS.; European beam, 10:15 am to 2:30 pm.
15.14	GSP	BOSTON, MASS.; North African beam, 7:45 am to 4:30 pm.	17.77	LRA5	BUENOS AIRES, ARGENTINA; Fridays, 5 to 5:30 pm.
15.150	WRCA	LONDON, ENGLAND; Near East, Africa and Gibraltar beam, about noon.	17.760	KROJ	LOS ANGELES, CALIF.; Australian beam, 9 to 10 pm.
15.150	WNBI	NEW YORK CITY; Brazilian beam, 5 to 7:45 pm.	17.760	WKRJ	NEW YORK CITY; South African beam, 10:00 to 11:15 am; Central Africa beam, 11:30 am to 12:30 pm.
15.155	SBT	NEW YORK CITY; European beam, 7:45 am to 3:30 pm.	17.780	—	LOCATION UNKNOWN; heard 11:45 am to 12:15 pm.
15.165	PRE9	STOCKHOLM, SWEDEN; heard daily, 11 am to 2:15 pm.	17.780	WRCA	NEW YORK CITY; European beam, 9 am to 2:45 pm.
15.170	TGWA	FORTALEZA, BRAZIL; evenings.	17.780	WNBI	NEW YORK CITY; East South American beam, 8:30 to 6:45 pm; Sundays, 5:30 to 7:30 pm.
15.190	KROJ	GUATEMALA CITY, GUATEMALA; daytimes.	17.800	TGWA	GUATEMALA CITY, GUATEMALA.
15.190	WKRJ	LOS ANGELES, CALIF.; N.E.I. Oriental beam, 2:30 to 8:45 pm.	17.830	WCDA	NEW YORK CITY; European beam, 7:45 am to 3:15 pm.
15.190	WKRJ	NEW YORK CITY; Central Africa beam, 7 to 9 am.	18.135	YDA	BATAVIA, JAVA (Netherlands Indies); India beam, ? to noon.
15.190	WKRX	NEW YORK CITY; European beam, 9:45 to 11 am; North European beam, 11:15 am to 12:45 pm; Central Africa beam, 1 to 5 pm.	20.040	OPL	LEOPOLDVILLE, Belgian Congo.
15.20	DJB	BERLIN, GERMANY; North American beam, 7 to 9:45 am; 5:50 to 8:30 pm.			

## SYSTEMATIC CIRCUIT TESTS

(Continued from page 217)

combination of one or more of them:

1. Set analyzer method.
2. Point-to-point resistance and voltage analysis.
3. Circuit disturbance method of isolation.
4. Stage squelching and elimination.
5. Signal substitution.
6. Signal tracing.
7. Visual dynamic analysis.

We must realize that the servicing of electronic equipment is an art, as well as a science, and it should be stressed that no one of these methods should be used to the exclusion of the others. Neither is any one method superior to any other. The successful trouble-shooter will make use of the method which accomplishes a particular job in the quickest and most efficient manner. So it is necessary to understand and be proficient in *all* the methods. In teaching radio to all types of students, experience shows that unusual results are obtained in trouble shooting; not only by allowing the student to shoot trouble, but by making

him use the correct method, or combination of methods.

Let us, therefore, analyze and study each of these methods and realize the advantages and limitations of each.

### THE ANALYZER METHOD

At one time the set analyzer was a common item around most radio service shops. The panel instrument may consist of 2 or 3 meters, a few tube sockets, an assortment of push button switches and jacks, and a rotary selector switch. Also included was a cable terminating in a 4- or 5-prong plug. Figure "A" shows a typical instrument of this type having 2 meters. The meters include a multi-range D.C. voltmeter, a multi-range D.C. milliammeter and in some models an A.C. voltmeter.

The set analyzer is an instrument which checks the operating voltage and current to each tube element in a receiver or other electronic device by means of the plug and cable and the tube sockets on its panel. The tube of the suspected stage is removed from



the chassis and placed in the proper socket on the analyzer, while the analyzer plug, with the proper adapter, is placed into the chassis socket vacated by the tube. Now, by rotating the selector switch or pressing the proper buttons on the analyzer, it is possible to check all voltage and currents, etc., since the switch automatically connects the proper meter in the circuit to measure the desired quantity.

Thus, obviously, we have a simple method of diagnosis. Observe that in the case of a radio receiver, it is not even necessary to remove the chassis from the cabinet, giving us the extreme advantage of simplicity.

In spite of these advantages, the set analyzer has become obsolete. It was at its best in the days of the 26, 27 and 71 or 45 tubes, when all sockets were either 4- or 5-pronged, and when there were only a few tubes of more or less uniform type. Now we have 6-prong, large and small 7, octal, loctal and bantam tubes and sockets. It is necessary to consult a manual frequently, even to find out which prongs are those of the filament. The danger of making wrong switch connections and damaging the instrument is great. To make matters worse, capacity between leads in the cable detunes some circuits. Before the gang condenser was common this was unimportant—now it throws the receiver out of operation and makes testing impossible.

Two reasons warrant consideration of the set Analyzer: Special set Analyzers are often furnished by manufacturers of military equipment for the armed forces and, the Free Point Analyzer, an improved outgrowth of the set Analyzer, is in quite common use today.

The Special Set Analyzers are so designed as to check only the tubes and stages of a particular piece of equipment. Consequently, it is not necessary to incorporate in their design facilities for checking tubes other than those actually in the device to be checked. The set-up is therefore simplified and has a minimum of parts and accessories. A person trouble shooting where such a special tester is available, is well advised to study and learn the technique by applying the instructions always provided.

#### THE POINT-TO-POINT METHOD

The Free Point Analyzer does not include any meters or selector switches in its makeup. It consists, rather, of one each of all type sockets and a cable with an arbitrary plug (most often a large 7 prong plug) and one adapter for each type tube socket. The sockets are wired with an arbitrary pre-arranged plan, as is typified in Fig. 1. Note that in this case all the No. 1 prongs are connected and form one wire of the cable. Each line also includes two jacks, one set of which may be colored red and the other black. An alligator clip usually connects to the chassis, or B-, of the device under test.

It can be seen that it is a simple matter to check the voltage or resistance (with the set off) between any two elements of a tube or between any element and ground. A separate volt-ohm-milliammeter must be used. The black jacks are used exclusively for these tests. To measure the current drawn by any element the red jacks come into use. Now it is only necessary to place the leads of the current meter, using the proper range and polarity, one lead to the red jack and the other to the corresponding black jack. Suppose it is necessary to measure the plate current of a 6J7 tube. A tube manual would tell us that the No. 3 prong is the plate in this tube. Placing the negative lead of the milliammeter in the No. 2 black jack on the analyzer and the

# HARRISON HAS IT!

**FOR URGENT  
WAR WORK—**

**HALLICRAFTERS**

**RECEIVERS AND  
TRANSMITTERS**

**TUBES  
CONDENSERS  
RESISTORS  
TRANSFORMERS**

**AND THOUSANDS OF OTHER  
CRITICAL ELECTRONIC PARTS!**

**PURCHASING AGENTS—**

Call upon us for your high priority requirements of equipment and components for your production and development work.

**We usually have it in stock!**

**FOR THE  
HOME FRONT—**

**CODE PRACTICE SET**

Buzzer and key, heavily nickel plated, of single unit construction, mounted on wood base. Adjustable high frequency pitch. Complete with silk covered cord. In attractive box with code chart on cover. Works on one or two flashlight or dry cells.

**Postpaid—\$2.45**

**6L6G First grade, \$1.37 ea.  
meter tested, 3 for \$3.75  
TUBES fully guaranteed postpaid**

**DYKANOL CAPACITORS**

Cornell-Dubilier oil filled, hermetically sealed metal cased condensers, 4 mfd. capacity. Rated at 220 Volts AC working, will stand over 600 Volts D.C. Ideal for amplifiers, receivers, power packs, etc. (Filtering action equivalent to 12 mfd. electrolytic but with better safety factor, longer life). \$2.25 (3 or more shipped postpaid).

**P. M. DYNAMIC SPEAKERS**

5 inch, with output transformer to match single plate of 8000 ohms **\$1.95**

(Not Postpaid)

Immediate delivery of the above items, without priority, while quantities last. Place L-265 or V-3 certification on your order. **SEND REMITTANCE WITH ORDER, TODAY!** (Money back if not satisfied.)

**HARRISON**  
RADIO CORPORATION

11 WEST BROADWAY

Phone WOrth 2-6276

NEW YORK CITY 7

positive lead in the No. 3 red jack, will determine the plate current, which is read on the milliammeter. When we measure current in this manner, a lead placed in any of the red jacks automatically opens the circuits to the line, placing the current measuring device in series with that line.

Notice that in order to measure the current drawn by any element, it is not necessary to unsolder the lead to that element. As a matter of fact, in the case of a radio receiver, the chassis does not even have to be removed from the cabinet, an advantage which is often ignored even by professional servicemen.

#### USING THE MULTIMETER

When we have isolated the defective stage and circuit with the set analyzer (or any of the methods to follow), it becomes necessary to track down the trouble to the defective part. In this case, it is desirable to turn the chassis upside down and use a multi-range volt-ohmmeter. We may use either voltage analysis or resistance analysis or both.

A typical application might aid in illustration. Consider the diagram of Fig. 2 which shows the plate-cathode circuit of a typical audio amplifier stage. Use of the set analyzer may have indicated that this stage lacked plate voltage. With the set on we connect our voltmeter from the cathode to point "a" on the B+ line. If the proper D.C. voltage is available at this point the cathode resistance is probably O.K. The trouble lies in the plate circuit between point "a" and the plate.

Assume that moving the prod to point "b" shows no voltage. This could indicate an open in R<sub>k</sub>, the decoupling resistance, or it may indicate a shorted decoupling con-

(Continued on following page)

## 2 IMPORTANT RADIO BOOKS

### BASIC RADIO

**JUST OUT!**

By G. L. Boltz, Well-known British Authority.



Covers the many principles of radio and gives the basic knowledge you need to study to go on to advanced work. Clarifies each essential idea by describing simple experiments and pointing out the facts. **CONTENTS:** Fundamental ideas and definitions. Ohm's Law. Magnetism and Electromagnetism. Induction. Condensers. Alternating Current. Uses of Inductance and Capacitance. Waves. Tubes. Use of Tubes (1) Oscillators, transmission of oscillations (2) Detection (3) R.F. Amplification (4) A.F. Amplification. Receivers. Aerials and Feeders. 272 Pages. 166 illus. \$2.25.

### AERONAUTIC RADIO

By M. F. Eddy, Licut. U. S. Navy, Ret'd.

A manual for Operators, Pilots, and Radio Mechanics. Follows requirements of the F.C.C. and C.A.A. and actual approved usage such as course guidance, and instrument landing. Thoroughly covers the theoretical part of the aviation radio operator's license examination. Helps to acquire quickly skill in operation of radio equipment and understand instructions. 502 Pages. 198 illus. \$4.50.

#### THE RONALD PRESS COMPANY

Dept. M882 15 East 26th St., New York 10, N. Y.

Please send me book checked:—

BASIC RADIO. Boltz ..... \$2.25

AERONAUTIC RADIO. Eddy ..... 4.50

On receipt I will pay postman cost plus few cents C.O.D. charges. If not entirely satisfied I may return them within 5 days. (Sent postpaid if you remit with order. Same Guarantee.)

Name .....

Home Address ..... City & State .....

Check here for complete Aeronautics' Book catalog.

## PRESERVE RADIO-CRAFT BACK ISSUES

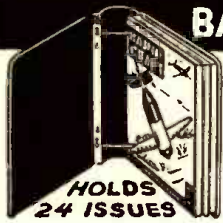

in this  
**PERMANENT  
BINDER**

HOLDS  
24 ISSUES

Heavily constructed, reconditioned and converted for binding 24 issues. 9" x 12" with 4 1/4" back. All you have to do is punch two holes in each copy of RADIO-CRAFT, slip it over the sturdy binding posts and snap in position.

Your magazine will be kept clean, fresh looking for instant reference—instead of lying around torn, dog-eared and soiled, and then more than likely lost.

**5 DAY FREE TRIAL**

Only a small quantity on hand. Guaranteed to satisfy, or return within 5 days and your money will be refunded. Send postpaid in U.S. and Canada. **\$1**

WHILE THEY LAST

**RADCRAFT PUBLICATIONS**

25 WEST BROADWAY NEW YORK 7, N. Y.

## 300 WAYS TO MAKE MONEY

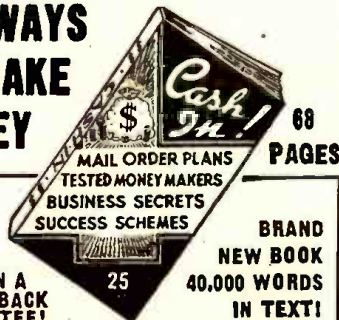

25c  
Per Copy

SOLD ON A  
MONEY-BACK  
GUARANTEE!

In "CASH IN" you get ALL the real money-makers—dozens of profitable tested mail order Plans, confidential business secrets, dozens of practical tested formulas, successful tested schemes—actual experiences of men who have started on a shoestring—with less than \$10 capital.

Buyers of This Book Tell Us—

"Biggest value I've yet to see. Book is worth at least a dollar." S. Buda, B'klyn, N. Y.  
"Your book is as good if not better than others selling at \$1.00."

George Brunet, Montreal, Can.  
"CASH IN is the best value I have yet to see in the mail order field."

Lawrence Fox, Brooklyn, N. Y.  
"CASH IN" contains only tested ideas covering every type of full- or spare-time enterprise—it's a "masterpiece" in business ventures.  
25c a copy postpaid. Send U. S. stamps or coin.

**NATIONAL PLANS INSTITUTE**  
P.O. Box 26R, Station N  
New York 23, N. Y.

## Complete Plans

For Building Useful and Practical Things at Home. Each issue of Popular Homecraft is crammed with plans for making such beautiful and useful things as: Furniture, Bird Houses, Lamps, Outdoor Garden Furniture, Candle Equipment, etc. Covers lathework, tool, wood-working, leathercraft, copper, etc. You'll find "how" to make almost everything from the pages of Popular Homecraft. Scores of drawings and photographs make every step simple as A B C. A real "How-To-Do-It" magazine.

Six Months' Trial \$1.00

Send \$1.00 today for trial six months' subscription Money Back if Not Delighted.

**POPULAR HOMECRAFT**

637 Palmolive Building Chicago, Ill.

**Trial 6 Months \$1.00**

## SYSTEMATIC CIRCUIT TESTS (Continued from previous page)

denser, Cr, although in this event the voltage at "a" would be somewhat lower than normal. Often the serviceman does not have the manufacturer's data available, so it would seem advisable to investigate further by shutting off the set, removing the line cord from the wall socket, and using the ohmmeter to check the resistance from point "b" to chassis. Zero or a very low resistance would point definitely to a shorted condenser, whereas a check from "a" to "b" would tend to indicate an open in Rr. Note: some experts recommend that the tubes be removed from their sockets when making ohmmeter measurements.

At one time, John F. Rider suggested that point-to-point resistance analysis be more widely used and in the Rider Manuals there appeared reference resistance values from various points to chassis. Apparently this advantage would apply only to the professional serviceman and commercial broadcast receivers. Furthermore, it is not advised that the trouble-shooter proceed from one end to the other of the chassis in order to locate a defective stage.

The set analyzer, or Free Point tester, supplemented by point to point analysis, was an ideal combination in the older days of radio, when sets were simple and there were few complex circuits appearing. Today, we must remember that we are at war and the maintenance men at or near the front cannot always spare the time to analyze a device one stage at a time. Faster methods must be employed whenever possible.

### CIRCUIT DISTURBANCE METHOD

The circuit disturbance method of isolation may be a real time saver, especially in the case of a receiver or an electronic device in which headphones or other indicator may be connected to the output. A further limitation in this method is that it is adapta-

ble generally only to dead or weak equipment.

In such cases we may simply and quickly determine the defective stage. In general it is unnecessary to remove the chassis from the cabinet. Refer to the block diagram of the typical superheterodyne receiver of Figure 3. This receiver is dead and it is desired to locate the defective stage. With the set on, pulling the power amplifier tube out of its socket should produce a loud click in the speaker, since a fairly large plate current is interrupted and the resulting signal voltage is transmitted to the speaker. Failure to hear a loud click might indicate a power amplifier stage which is not operating. No click from any tube would usually indicate that no D.C. operating voltages were being delivered to the tubes by the rectifier-filter, and we would look for our trouble in the power supply.

Suppose the power amplifier did produce a click. We could now proceed towards the antenna one stage at a time to find out which stage was at fault. While the earlier stages involve plate currents of smaller magnitude than that of the power stage, and it might seem that the click will be weaker, let us keep in mind that we now have available the gain of the following stages to amplify the noise signal and make it even more audible. Let us say that in this case, pulling the first I.F. tube out of its socket produced no click, while a click was forthcoming from the following stages. We could conclude logically, that the trouble lay in this 1st I.F. stage. Now the use of the free point tester (or set analyzer if available and usable) to indicate the defective circuit, and the multimeter to track down the ailing part, would soon locate the trouble.

It should be pointed out at this time that we actually used a combination of three methods. Now, you see, we are developing a technique—and saving time!

## HUGHES BALANCE METAL DETECTORS (Continued from page 220)

backward, may be used here.

In Fig. 4 we have a (purely theoretical) voltage-operated type of balance. The push-pull circuit would be activated only when unbalanced voltages were set up in the two "receiver coils." Some means would have to be provided for obtaining a null point. This could be done by providing a potentiometer for the ground connection. A few hundred ohms should be sufficient for this, once the rough adjustments had been made by moving the coils.

The oscillator, buzzer, or other source of signal, is now started, and the receiver coils adjusted by moving one or the other slightly up or down on the center rod, till no sound is heard from the amplifier.

The two secondary inductors are now perfectly balanced. Currents set up in each one of them by the primary or "transmitter" winding, are exactly equal in strength, and as they are opposite in direction they buck out completely in the output. (Needless to say, loud signals with no sign of a null point indicate that the coils are aiding instead of bucking, and the leads of one of them should be reversed.)

Now, if a coin or other small piece of metal is placed on the center of one of the discs, the balance will be disturbed, and a signal will be heard. If an identical coin is placed on the other disc, balance will be restored and the signal will cease. So delicate

is the balance that the difference between a genuine and a counterfeit coin may be detected. If two identical coins are used, but if one is only even slightly worn, the balance is then upset too.

The Hughes Induction Balance became a subject of discussion as a result of an editorial in the October issue, in which it was mentioned as a possible basis for an improved mine-locator. Since a very small piece of metal in the field of one of the coils can upset the induction balance and give an audible signal, it would seem that it might be used to detect devices which contain only a few small metallic parts.

The difficulties in the way of constructing a practical piece of equipment for field work lie in the delicate balance necessary—

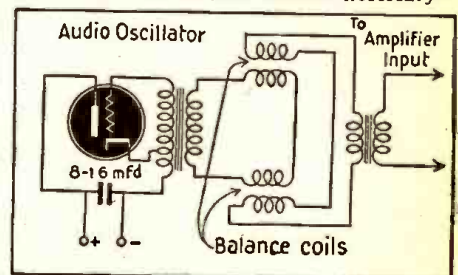

Fig. 3—Suggested circuit for a Hughes Balance.

a balance not easy to maintain in mobile equipment. The practical Hughes metal locator would probably consist of two units, each with one primary and one secondary coil. These would be constructed with a light but rigid frame, so that the separation between each primary and its secondary

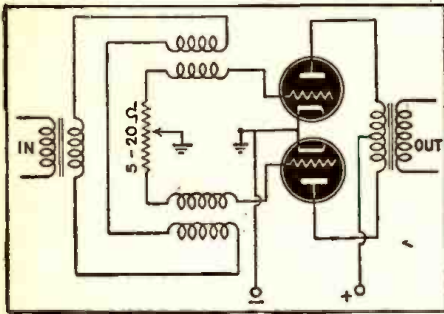

Fig. 4—Experimenters will be interested in the circuit above, which uses push-pull principles.

would be absolutely fixed. The coils would be large in diameter—possibly 3 to 6 feet, and the two units would conceivably be separated far enough to make effects from the primary of one unit to the secondary of the other small enough to be negligible.

If this balance was sufficiently sensitive to be useful with the crude microphones and telephone receivers of 50 years ago, its range should be extensive when used with modern apparatus, plus amplification, which the original experimenters with the Hughes apparatus did not have at their command.

Not only is this old-time instrument worth some attention—no doubt there are a number of other ideas and devices which were impractical in pre-electronic days—which now might be very useful instruments. A little browsing through old scientific books would possibly yield a worth-while reward.

### SERVICE NOTE ON 35Z5'S

Radio-Craft has received a number of suggestions concerning the use of 35Z5's which have the pilot lamp section burned out—a common failure in these tubes. Almost every mail brings in a "hint" from some serviceman who has found that these tubes are not completely destroyed, and can be put back into use.

The commonest suggestion is simply to short pins 2 and 3 with a piece of wire. This puts the tube back into operation, but has two disadvantages. The pilot lamp cannot be used when such a "repair" is made. The voltage on the filaments will also be increased beyond what was intended by the designer, though this increase, divided among all the filaments of the set, should not be harmful.

A better idea is to put a resistor of about 30-60 ohms between these two terminals. While the cathode of a tube so repaired will not reach the same temperature as that of one in good condition, this method is fairly satisfactory on sets of low current drain. It also permits the pilot lamp to light. The higher the shunting resistance, the brighter the lamp will be.

A third suggestion, which solves the problem of finding a suitable resistor, is to simply hook an additional 150-Ma. pilot lamp up between the prongs 2 and 3. The two lamps then light with equal brilliance.

Certainly none of these repairs are as good as replacement with a new tube. In cases where the new tube is unavailable such repairs will put a radio into practically normal working condition where otherwise it would have to be laid up.

### FCC MOVES FOR AVIATION SAFETY

RADIO tower lights must be kept in good condition. Recent regulations of the FCC are aimed at making sure that this is done. Under the new regulations, a visual observation of the light must be made daily, and a thorough inspection of all mechanical associated equipment every three months. Station logs must now keep a record of

the time lights are turned on and off daily and record the time of each daily observation and tri-monthly inspection. When failure of tower lights occurs, the log must state the time of failure, time that illumination was resumed, and both the cause of failure and the steps taken to prevent its re-occurrence.

### Inventions Wanted Patented or Unpatented

We have been successfully selling inventions, patented and unpatented, since 1924. Write us, if you have a practical, useful idea for sale.

**CHARTERED INSTITUTE OF AMERICAN INVENTORS**

Dept. III, 631 Pa. Ave., N.W., Washington, D.C.

### STUDY AT HOME

With a Chartered Educational Institution

Courses in Arts; Sciences; Philosophy; Education; Public Health; Medical Jurisprudence; Psychology; Sociology; Physics; Chemistry; Geology; Pol. Science; Theology; Law; Business Training; Accounting; Math.; Statistics; Agriculture; ENGINEERING; RADIO; Electrical; Civil; Mechanical; Drafting; Architectural; Steam; Aeronautical; Structural; Industrial; Highway; Petroleum; Mining; Marine; Chemical.

**McKINLEY-ROOSEVELT INCORPORATED**

4610-VI Sheridan Road Chicago, 40

# SUBSCRIBE NOW

# TO-

# AND RECEIVE FREE THIS DICTIONARY

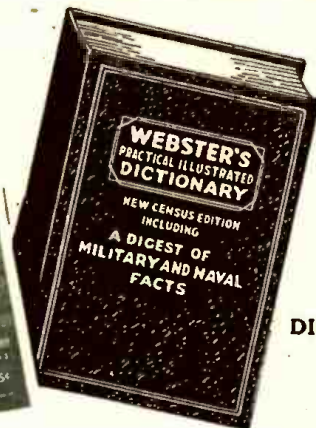

FULL LIBRARY SIZE WEBSTER DICTIONARY 378 PAGES

**FIVE MONTHS \$1.00**

**TWELVE MONTHS \$2.00**

### SPECIAL NOTICE TO OUR READERS

Due to wartime curtailment of paper, we are unable to meet the increasing newsstand demand for RADIO-CRAFT. We are therefore making this special introductory offer to our readers. Assure yourself of getting a copy of RADIO-CRAFT monthly by subscribing now and at the same time co-operate in making this wartime measure effective. Don't delay—Send in your order today. Take advantage of our special long-term offer and protect yourself against any possible increase in price by sending \$2.00 for 12 issues.

If you will take advantage NOW of our special subscription offer of five months for \$1.00 or twelve months for \$2.00, we will send you ABSOLUTELY FREE and POSTPAID this 378-page WEBSTER'S PRACTICAL ILLUSTRATED DICTIONARY—useful and instructive to all. This self-pronouncing authoritative dictionary—a brand new work throughout—contains the most up-to-date words now in common use. Over 20,000 definitions in all. In addition, it has the following: List of Largest Cities in the U. S.; List of Principal Cities of the U. S.; List of Principal Cities of Canada; National Parks of the U. S.; Time and its Variations; Tables of Weights and Measures; Presidents of the U. S.; Synonyms and Antonyms; Dictionary of Commerce and Law; Dictionary of Forms of Address; Military and Naval Information (illustrated); Digest of the Purposes of Current Federal Agencies.

### THIS IS A TIME LIMITED OFFER

MAIL COUPON TODAY FOR A SUBSCRIPTION AND DICTIONARY

**RADIO-CRAFT**  
25 WEST BROADWAY  
NEW YORK 7, N. Y.

RADIO-CRAFT DEPT. 1-44, 25 WEST BROADWAY, NEW YORK 7, N. Y.

Gentlemen: Enclosed you will find my remittance for which enter my subscription to RADIO-CRAFT Magazine for the period checked below. Send me ABSOLUTELY FREE and POSTPAID the Webster Dictionary.

5 months — \$1.00  12 months — \$2.00  
 This is a new order  Renewal

NAME \_\_\_\_\_ Please Print Clearly

ADDRESS \_\_\_\_\_

CITY \_\_\_\_\_ Postal (if) \_\_\_\_\_ STATE \_\_\_\_\_  
Dist. No. (any)

Remit by check or money order; register letter if you send cash or unused U. S. Postage Stamps. (Canadian and foreign orders must be accompanied by an International Money Order.) On Canadian orders add 60c for postage; on foreign add 75c for one year.

# WANTED

For the

## PHILCO ENGINEERING STAFF

- **RADIO TECHNICIANS**  
Ham operators and radio service men familiar with test equipment.
- **RADIO-ELECTRONICS-ELECTRICAL ENGINEERS**  
Men with degrees in electrical engineering or comparable experience in radio and television.
- **MECHANICAL ENGINEERS**  
Men with college degrees or comparable experience in the engineering aspects of electrical appliances, and in designing small machinery.
- **DESIGN ENGINEERS — DRAFTSMEN**  
Men with experience in mechanical designing, especially of small metal parts and of the automatic machinery to mass-produce them.
- **MODEL MAKERS**  
First class precision workers and all-round mechanics capable of starting with blueprints, making the parts required and assembling the finished models.

**W**E expect the men who qualify for these positions to become permanent members of our staff and take an important part in our post-war program.

To maintain the Philco tradition of progressive research and development, is first and foremost in our minds. In such an atmosphere of encouragement most engineers find they do their best work. To aid them, we provide the finest of technical equipment. But often, even more helpful is the inspiration and personal assistance they gain here at Philco in working with men who have done so much for the advancement of Radio, Television, Refrigeration and Air-Conditioning.

### WRITE US TODAY

Qualified men not now engaged in work requiring their full talents, are invited to write us in detail as to their experience, education, family and draft status, and salary. Letters will be treated in strict confidence.

*Hiring subject to local W. M. C. rulings.*

WRITE TO MR. GEORGE DALE

# PHILCO

**CORPORATION**

Philadelphia 34, Penna.



## ENGINEERS WANTED

RADIO AND MECHANICAL ENGINEERS WANTED FOR WAR AND POST-WAR DESIGN WORK IN THE FIELDS OF:

**AERONAUTICAL RADIO  
COMMUNICATION RADIO  
COMMERCIAL RADIO  
DETECTION DEVICES  
BROADCAST RECEIVERS  
TELEVISION  
OTHER ELECTRONIC FIELDS**

A DEGREE IN ENGINEERING OR PHYSICS OR ACTUAL DESIGN EXPERIENCE IN THESE FIELDS IS REQUIRED.

POSITIONS ARE PERMANENT FOR SUCCESSFUL APPLICANTS. WRITE, GIVING FULL DATA ON EDUCATION, EXPERIENCE AND SALARY DESIRED.



## COLONIAL RADIO CORPORATION

254 RANO ST.  
BUFFALO 7, N. Y.



## ELECTRONIC ENGINEERS

Technical college degree, at least 2 years experience, to work for corporation having divisions located throughout U. S. Position with important and extensive future. Present production and development work on products normally used by industrial and civilian markets—entirely absorbed by war needs. Engineering aspects extend far beyond radio. Salary open. All inquiries confidential.

Write fully to Box 104, c/o Radio-Craft Magazine

# Electronic Engineers

**S**EVERAL high calibre electronic engineers wanted with proven technical ability and well-balanced background in acoustics, broadcasting, frequency modulation, ultra high frequencies, special device circuits. Opportunities exist in designing, development and manufacturing of cathode ray, transmitting and general-purpose tubes; communications, electronic and precision test equipment.

Fast-growing company now in war production. Has worldwide background in electronic research and development; sound postwar future. In replying give age, draft status, technical education, training and experience; salary requirements, availability. Enclose photograph. Address President, North American Philips Company, Inc., Dobbs Ferry, N. Y.  
If working in essential industry at highest skill, please do not apply.

## RADIO-ELECTRONIC TESTERS TECHNICIANS EXCELLENT OPPORTUNITIES IN A MAJOR POST WAR FIELD

Openings available at our Research Laboratories and Electronic manufacturing unit. Leaders in the design and development of vital electronic equipment for the armed forces.

Essential workers need release statement.

Write, stating experience, education, draft status, salary requirements or apply to

### SPERRY

**GYROSCOPE CO., INC.**

RESEARCH LABS. & ELECTRONIC  
PLANT  
STEWART AVE. & CLINTON RD.  
GARDEN CITY, NEW YORK

## RADIO WRITERS

Resident in the New York Metropolitan area. For part or full-time work on established radio magazine. Capable of writing articles on assigned radio or electronic subjects, expand or digest technical data, press releases, etc., or to carry on research work under editorial direction. Apply

Box 27, Radio-Craft

25 West Broadway, New York 7, N. Y.

## WANTED

Radio engineers & electrical engineers with radio background. Attractive openings in war plant with post war possibilities. Essential workers need release statement.

Allen D. Cardwell Manufacturing Company  
81 Prospect St., Brooklyn, New York

## WESTERN ELECTRIC CO.

In PEACE  
Source of supply for the  
Bell System

In WAR  
Arsenal of communication  
equipment

## NEEDS INSPECTION ENGINEERS

For quality  
control work.

Men or Women

Background required: Knowledge of D.C., A.C. and electronic theory. High school with some college background in Physics and Mathematics or radio school essential. Experience in amateur radio with license desirable but not required.

To do inspection and testing of radio and other high-frequency equipment.

Release statement and  
U.S.E.S. consent needed

Write or apply in person to  
A.C.C., Employment Dept.

100 Central Ave.  
Kearny, N. J.

Monday through Saturday.  
8:30 A.M. to 5 P.M.

# -ENGINEERS-

**NATIONAL UNION  
OFFERS A GREAT  
OPPORTUNITY**

National Union Radio Corporation, long acknowledged as a national leader in vacuum tube manufacture, is building a greater research and engineering staff. Our contribution to the war effort has been substantial; our plan for the future knows no bounds. If you get into this electronic tube picture now, you have a brilliant future, unlimited horizons ahead.

Our laboratories are in Newark, New Jersey.

We prefer men with a degree in electrical engineering, physics or mathematics and a knowledge of vacuum tubes; however, if your experience warrants, a degree is not absolutely essential. You must be draft exempt and not now employed full time at highest skill in a war industry.

### CAN YOU QUALIFY AS:

- Electronic tube engineer
- Metallurgist
- Production engineer
- Development engineer
- Measurement engineer
- Physicist
- Electrical engineer

Write at once and tell us your experience, education, draft status, salary requirements.

## NATIONAL UNION RADIO CORPORATION

48 Spring St., Newark, New Jersey

# WESTERN ELECTRIC CO.

In PEACE  
Source of supply for the  
Bell System  
In WAR  
Arsenal of communication  
equipment

NEEDS

## ELECTRICAL TESTERS

MEN AND WOMEN

For Radio Transmitters & Re-  
ceivers & similar equipment.

Young men and women  
who have been licensed  
radio amateurs preferred  
or those having a good  
technical knowledge of  
voice communication and  
trained in electrical test-  
ing of radio equipment  
are needed for inspectors  
and testers.

Release statement and  
U.S.E.S. consent needed.

WRITE OR APPLY TO  
C.R.L., DEPT. 4816

100 Central Ave.  
Kearny, N. J.

Mon. through Sat. 8:30 a.m.-5:00 p.m.



HIGH EFFICIENCY  
results in  
Sound National  
Defense  
that is why  
NATIONAL DE-  
FENSE SOUND  
SYSTEMS  
are equipped with  
Unisonity Reflex  
HIGH POWER  
LOUDSPEAKERS  
UNIVERSITY LABS.  
225 VARICK ST. N. Y. C.

University

### STANDARD FREQUENCY SERVICE

WWV, the standard-frequency station of the Bureau of Standards at Beltsville, Md., now operates on three frequencies and maintains a continuous day and night service.

Service is continuous on 5 and 10 megacycles, and during the hours of daylight (at Washington, D. C.) on 15 megacycles. All three frequencies carry two audio frequencies at the same time, 440 and 4,000 cycles per second. In addition there is a pulse every second, heard as a faint tick.

Audio frequencies are interrupted on the hour and every five minutes thereafter, for precisely one minute, during which interval the station call letters are given in code, with voice announcements at the hour and half-hour. Accuracy of all frequencies is better than 1 in 10,000,000.

## Available Radio-Electronic Literature

Manufacturers' bulletins, catalogs and periodicals.

**A NEW SERVICE FOR RADIO-CRAFT READERS:** In order to save your time, postage and incidental work in writing a number of letters to different manufacturers to secure the various bulletins offered, proceed as follows:

On your letterhead (do not use postcards) ask us to send you the literature which you designate. It is only necessary to give us the numbers. We will then send your request directly to the manufacturers, who in turn will send their bulletins or other literature directly to you.

101. **HERE'S HOW**, a 20-page booklet issued by the International Resistance Co., with 10 tested ideas to help solve volume control replacement problems.

Methods of replacing the now unobtainable dual wire-wound volume-control units with available controls, of replacing tapped volume controls and bass compensating circuits are outlined in this timely and useful little book. Even the replacement of volume controls with fixed resistors in emergency cases is suggested and a method given.

A number of other helpful suggestions are made, such as a variety of ways of using old volume control shafts, with improvised couplers, where extended shafts are required, and precautions necessary in substituting power type wire-wound resistors, as well as methods of figuring fixed resistor substitutes. Formulas for determining required wattage, current and resistance values in circuits under repair are given, and the book closes with a very useful chart in which all these calculations are ready-made, and it is only necessary to put a ruler across the chart to discover the resistance and wattage required in a resistor for any given job.

This book is free, and may be obtained by simply addressing a post-card or letter request to Here's How, c/o Radio-Craft, 25 West Broadway, New York 7, N. Y.

102. **FREQUENCY CONTROL** with Quartz Crystals, Bliley Electric Co. An engineering bulletin of 35 pages, covering the general theory and application of quartz piezo-electric crystals.

Starting with a theoretical discussion of the action of quartz crystals, this booklet goes into a detailed treatment of the specific action in resonant and anti-resonant circuits, power, activity, modes of vibration and temperature effects. Turning to the practical, the reader is introduced to crystal holders and methods of cleaning crystals.

Description of all the main types of crystal-controlled oscillators, with circuits is included and space is given to the use of the crystal in frequency standards and the use of a multivibrator in connection with a crystal to provide subfrequencies.

The book is well and clearly written, and rendered convenient for reference by a table of contents—Price 10c.

### G-E FORECASTS POST-WAR TELEVISION

An interesting preview of "the newspaper of the future" was given to the public by General Electric television engineers last month, when fifty editors and publishers saw the evening edition of the Schenectady *Times-Union* dramatized.

The graphic method as well as straight television was used in bringing home the news to the television "readers." Piles of silver dollars were used to make Govern-

103. **SOUND ADVANCES**, a technical periodical for the development of automatic graphic recorders. Published by the Sound Apparatus Co., New York City.

A six-page bulletin. The latest copy received contained a technical description of the company's PS graphic recorder, a list of its uses in making measurements of gain, frequency and sensitivity in such items as speakers, transmission lines, amplifiers and microphones, for acoustic, radio and noise measurements, and some notes on the instrument.—Gratis.

104. **GAMMATRON ELECTRONIC PRODUCTS**, Heintz & Kaufman. A catalog of Gammatron transmitting tubes. Each tube is fully described, with technical reference material covering its uses in all types of circuits for which it is fitted. In the cases of some tubes, four or five classifications, ranging from Class B to Class C ultra-high-frequency conditions, are given, together with characteristic curves—Gratis.

105. **HEAVY DUTY CARBON LAMPS**. North American Electric Lamp Co. A leaflet describing carbon filament lamps ranging from 7½ to 120 watts, in various shapes, sizes and glass color. While these lamps are intended for industrial use, the radioman is often interested in the carbon-filament lamp as a resistor. Special lamps, including miniature 2 to 8 candle-power types, heat, baking and other large therapeutic lamps and high-voltage (220-250) pilot lamps are also listed—Gratis.

106. **PRICE LIST OF AMERICAN STANDARDS**. The American Standards Association. A list of American Standards and American Recommended Practices. Covers Engineering, (including the National Electrical Code), Commercial Standards, Safety Standards, and the new American War Standards, including those on Electrolytic Capacitors, Ceramic Radio Insulating Materials, Transformers and Reactors for home radio receivers and Mica Capacitors—Gratis.

107. **FOOTE PRINTS**, a quarterly issued by the Foote Mineral Co. A small magazine which runs to fifty pages, dealing with items of interest to the company. Technical in tone, it often carries matter of interest to the electronic engineer. Gratis to interested parties.

ment tax proposals clear. But it was the advertisers who had a real field day. Girl models, wearing the latest creations, stepped from department store advertisements. A baby buggy offered for sale in a want ad. was wheeled into view, giving prospective buyers an opportunity to appraise it. The final touch was a "Help Wanted" ad, in which a housewife and an applicant for the position of maid interviewed each other.

## TRANSMITTERS FOR FM

(Continued from page 213)

form this detection. In Fig. 7(a) is shown a super-regenerative grid leak detector. At 7(b) is shown the response curve of this detector. When the regeneration control C1 is set to the point of maximum sensitivity, the response curve will be relatively broad as shown. This curve at 7(b) represents the response of the tank circuit T at the maximum sensitivity point. Let us suppose that the maximum deviation of the carrier is 15 kc. and the detector response is 45 kc. as shown. By tuning the detector off to one side of the response curve from point C to D detection occurs. It is seen that the tuned circuit is operated at the middle of the straight portion on either side of the resonance curve, with the upper frequency limit at B and the lower frequency limit at C. These limits approximate the linear response portion. As the mean frequency deviates to maximum, the excursion D to B takes place and the R.F. voltage applied to the detector grid is positive, and as the mean frequency deviates to minimum excursion D to A occurs and the R.F. voltage applied to the detector grid is negative. Any excursions above point B, or below point A, would result in non-linear distortion. From this discussion it is evident that the resonant action of T converts the FM signal into an AM signal and this AM signal is detected in the usual manner. This is the simplest method of FM detection, but with the large channel width of high fidelity FM broadcast it is entirely impractical, because of the non-linear distortion introduced. It does explain, however, the principle involved, and why many AM receivers have picked up FM satisfactorily.

## HALLICRAFTERS ★ HALLICRAFTERS

### LET'S ALL PITCH IN!

WE CAN all help win this war by selling our government the communications receivers and equipment they need quickly and in sufficient quantities.

That is the reason I pay *highest cash prices* for used communications equipment.

When this war is over you will be in the market for new equipment and by taking advantage of my offer to purchase your present equipment at highest cash prices you will be in a position to buy new and better equipment than you now own.

Write, telephone or telegraph me description of your used communications receivers, transmitters and parts of standard make; you will be paid cash immediately without bother or red tape. I am particularly interested in *Hallcrafters*.

I also have a store at 2335 Westwood Blvd., West Los Angeles, Calif.

**Bob Henry, W9ARA**  
**HENRY RADIO SHOP**  
BUTLER, MISSOURI

"WORLD'S LARGEST DISTRIBUTOR OF COMMUNICATIONS RECEIVERS"



FM detectors are known as discriminators. These operate on an entirely different principle from the detectors used in AM circuits. The FM signals are effective to the extent that they deviate from a certain medial frequency, and the discriminator registers such deviation. There are several types of these, and as a description of their action and theory requires considerable space the next installment of this series will be devoted to a discussion of their action.

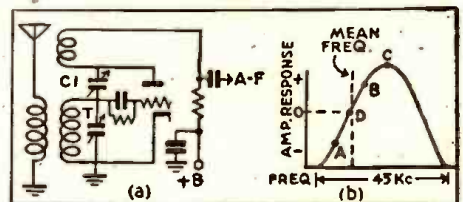

Fig. 7—How an AM receiver can receive FM.

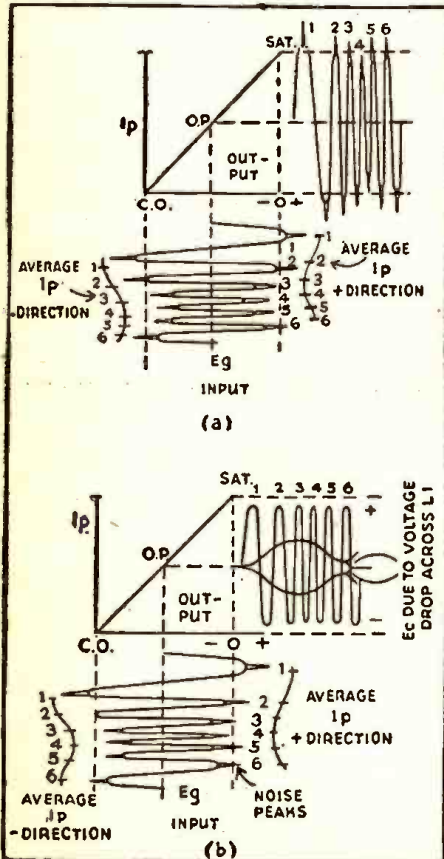

Fig. 6—Action of the feedback limiter. This is the more effective type, but needs strong signals.

### SERVICEMAN'S ONLY SALVATION IS INGENUITY

INGENUITY, not to overlook patience, is the salvation of wartime servicing, points out Vic Mucher who heads Clarostat sales and keeps in close touch with wartime servicemen not only through his jobbers but also through Government and trade association activities aimed at keeping those home radios perking and putting out the news for the duration at least.

"The Serviceman and likewise his Jobber must by now be awake to the fact that parts catalogs are just nice picture books these days," states Mr. Mucher. "You usually can't get what you see listed. The reason is simple enough: this is an all-out war. Parts manufacturers are by now engaged 100% on war production. The Government tells us what to make, when to make it, and for whom. As soldiers on the production front, we carry out orders, faithfully, unflinchingly, and without question."

"In our own line, such items as ballasts, bleeder resistors and exact-duplicate volume controls are no longer in regular production. Only a tiny trickle is occasionally diverted to essential civilian replacements. If we get an

order for one or two items, even though standard but out of stock at the moment, we just can't fill the order. That's war.

"Meanwhile there's much the serviceman can do. If a given ballast is unavailable, he can use one or more fixed or adjustable resistors to obtain the necessary resistance values. Likewise with bleeder resistors. Also with exact-duplicate volume controls. These days it is imperative that standard controls be used. Victory lines seek to reduce various parts to the lowest possible variety of types and values covering the greatest percentage of standard radio set replacements. Such simplification is absolutely necessary.

"Substitute or improvise with standard parts or values wherever possible. Cooperate with your parts manufacturers in making a success of such Victory types as may be set up. Furthermore, and this is important, use that junk box and use the good parts from discarded sets whenever possible in securing items that still have some useful life left in them. We must make everything last and last—for the duration."

# MATHEMATICS FOR RADIO

Two volumes, prepared for home study. Book I (314 pp.) covers the algebra, arithmetic, and geometry; Book II (329 pp.) covers the advanced algebra, trigonometry, and complex numbers necessary to read technical books and articles on radio.

MAEDEL PUBLISHING HOUSE Room 102  
593 East 38 Street, Brooklyn, New York

Send me MATHEMATICS FOR RADIO AND COMMUNICATION as checked below. I enclose payment therefor with the understanding that I may return the book(s) within 5 days in good condition and my money will be refunded.

Name .....

Address .....

- Book I at \$3.75 plus 6c postage  
 Book II at \$4.00 plus 6c postage  
 Books I and II at \$7.75 postage prepaid

Foreign and Canadian prices 25c per volume higher

## NOW—A REALLY HIGH-POWERED—Radio Engineering Library

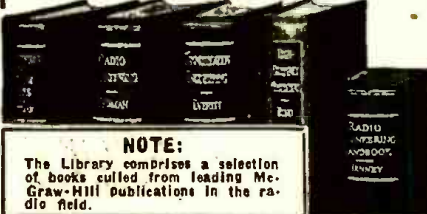

**NOTE:**  
The Library comprises a selection of books culled from leading McGraw-Hill publications in the radio field.

- especially selected by radio specialists of McGraw-Hill publications
- to give most complete, dependable coverage of facts needed by all whose fields are grounded on radio fundamentals
- available at a special price and terms

THESE books cover circuit phenomena, tube theory, networks, measurements, and other subjects—give specialized treatments of all fields of practical design and application. They are books of recognized position in the literature—books you will refer to and be referred to often. If you are a practical designer, researcher or engineer in any field based on radio, you want these books for the help they give in hundreds of problems throughout the whole field of radio engineering.

### 5 VOLUMES, 3319 PAGES, 2289 ILLUSTRATIONS

1. Eastman's FUNDAMENTALS OF VACUUM TUBES
  2. Terman's RADIO ENGINEERING
  3. Everitt's COMMUNICATION ENGINEERING
  4. Hurd's HIGH FREQUENCY MEASUREMENTS
  5. Henney's RADIO ENGINEERING HANDBOOK
- 10 days' examination. Easy terms. Special price under this offer less than books bought separately. Add these standard works to your library now; pay small monthly installments, while you use the books.

10 DAYS' FREE EXAMINATION—SEND COUPON

McGraw-Hill Book Co., 330 W. 42nd St. New York 18  
Send me Radio Engineering Library, 5 vols., for 10 days' examination on approval. In 10 days I will send \$3.00 plus few cents postage, and \$3.00 monthly till \$24.00 is paid, or return books postpaid. (We pay postage on orders accompanied by remittance of first installment.)

Name .....

Address .....

City and State .....

Position .....

Company .....

## DATA ON TWO NEW TUBES

The following data was omitted for reasons of space from the article last month.

**RCA—2C22  
AMPLIFIER TRIODE  
(Tentative Data)**

Maximum Ratings Are Design-Center Values  
Amplifier

Plate Voltage	300* max.	Volts
Plate Dissipation	3.3 max.	Watts

Characteristics—Class A<sub>1</sub> Amplifier:

Plate Voltage	300	Volts
Grid Voltage	-10.5	Volts
Amplification Factor	20	
Plate Resistance	6600	Ohms
Transconductance	3000	Micromhos
Plate Current	11	Milliamperes

\* This value is for Continuous Commercial Service (CCS). In intermittent Commercial and Amateur Service (ICAS), the plate voltage may be as high as 500 volts maximum but the maximum plate dissipation remains unchanged.

† The d-c resistance in the grid circuit should not exceed 1.0 megohm.

○ With no external shield.

**RCA—6J6  
TWIN TRIODE  
Miniature Type  
(Tentative Data)**

Maximum Ratings Are Design-Center Values  
A-F Amplifier

Plate Voltage	150 max.	Volts
(Each Unit)	1.5 max.	Watts

Plate Dissipation

Characteristics—Class A<sub>1</sub> Amplifier—Each Unit

Plate Voltage	100	Volts
Cathode Bias Resistor**	50*	Ohms
Plate Current	3.5	Milliamperes
Amplification Factor	32	
Plate Resistance	6000	Ohms
Transconductance	5300	Micromhos

R-F Power Amplifier and Oscillator—  
Class C Telegraphy

D-C Plate Voltage	150 max.	Volts
D-C Grid Voltage	-40 max.	Volts
D-C Plate Current (per unit)	15 max.	Milliamperes
D-C Grid Current (per unit)	8 max.	Milliamperes
D-C Plate Input (per unit)	2.25 max.	Watts
Plate Dissipation (per unit)	1.5 max.	Watts

Typical Operation at Moderate Frequencies in Push-Pull—Both Units:†  
(Key-down conditions per tube without modulation)

D-C Plate Voltage	150	Volts
D-C Grid Voltage	From a fixed supply of -10	Volts
From a grid resistor of	625	Ohms
From a cathode resistor of	220	Ohms
D-C Plate Current	30	Milliamperes
D-C Grid Current (Approx.)	16	Milliamperes
Driving Power (Approx.)	0.35	Watt
Power Output (Approx.)	3.5	Watts

- In circuits where the cathode is not directly connected to the heater, the potential difference between heater and cathode should be kept as low as possible.
  - \*\* Under maximum rated conditions, the resistance in the grid circuit should not exceed 0.5 megohm with cathode bias. Operation with fixed bias is not recommended.
  - Value is for both units operating at the specified conditions.
  - † Approximately 1.5 watts can be obtained when the 6J6 is used at 250 Mc as a push-pull oscillator with a plate voltage of 150 volts, with maximum rated plate dissipation, and with a grid resistor of 2000 ohms common to both units.
- The center hole in sockets designed for this base provides for the possibility that this tube type may be manufactured with the exhaust-tube tip at the base end. For this reason, it is recommended that in equipment employing this tube type, no material be permitted to obstruct the socket hole.

Photochemical mines, which explode when exposed to light, have been reported in the wake of the Nazis fleeing from the Dnieper area. Working on somewhat the same principle as the photo-cell alarm, they may lie for long periods in cellars or closets, exploding when an opening door permits light to reach them. Needless to say, this type of mine is far more dangerous to the returning civilian population than to the pursuing Red Army men.

## PATENTS—TRADE MARKS

Booklet concerning Inventions & Patents Form "Evidence of Conception" with instructions for use and "Schedule of Government and Attorneys Fees"—Free

LANCASTER, ALLWINE & ROMMEL  
Registered Patent Attorneys

436 Bowen Bldg. Washington, D. C.

## Index to advertisers

Allied Radio Corp.	238
Audel & Company	Back Cover
Amplifier Co. of America	245
Burstein-Applebee	245
Cannon Company, C. F.	245
Cardwell Co., Allen D.	251
Chartered Institute of American Inventors	249
Chicago Novelty Co., Inc.	239
Colonial Radio Corp.	250
Echophone	227
General Electric Co.	234
Gold Shield Prods.	241
Hallicrafters, Inc.	195, 196
Harrison Radio	247
Henry Radio	253
Hudson Specialties	240, 244
Lancaster, Allwine & Rommel	254
Maedel Publishing House	254
McGraw-Hill Book Co.	254
McKinley-Roosevelt	249
Meissner Manufacturing Co.	235
National Plans Institute	248
National Radio Institute	193
National Schools	237
National Union Corp.	198, 251
Nelson Company	243, 246
North American Philips Co.	251
Onan & Sons, D. W.	243
Opportunity Adlets	242
Philco Corp.	250
Pioneer Gen-E-Motor	233
Popular Homecraft	248

## RADIO SCHOOL DIRECTORY

Page 256

American School	
Candler System	
Capitol Radio Engineering Institute	
Commercial Radio Institute	
Lincoln Engineering School	
New York YMCA	
RCA Institutes	

Radcraft Publications, Inc.	229, 241, 242, 248, 249
Radio & Technical Division of	
Murray Hill Books, Inc.	223
Ronald Press	247
Rothstein, Albert	239
Sperry Gyroscope	251
Sprague Products Co.	225
Sprayberry Academy of Radio	197
Supreme Publications	
Inside Back Cover	
Supreme Instruments Corp.	236
Sylvania Electric Co.	232
Technifax	242, 246
Teleplex	246
Triplett Electrical Instrument Co.	241
University Laboratories	252
Western Electric Co.	251, 252
Weston Electrical Instruments	
Inside Front Cover	

(While every precaution is taken to insure accuracy, we cannot guarantee against the possibility of an occasional change or omission in the preparation of this index.)



# The Mail Bag

## ARE BEGINNERS NECESSARY?

Dear Editor:

I've just finished reading your latest magazine, and one letter in particular in the Mail Bag I am disgusted with—that of Mr. Esluk. He may want to have more technical knowledge, and the best way I know is his own suggestion—buy some small books for a few dollars that will cover the entire subject. There are many good small books on such subjects as FM and different phases of new developments of radio and electronics.

In my opinion beginners are the backbone of the radio profession and should be encouraged rather than discouraged, as Mr. Esluk suggested in so many words. I'm not what you would call a radio man as yet. I am 18 years old and have been studying radio since I was 12, and a lot of what I've learned has come from this magazine. I am now stationed in a radio repair shop of the United States Coast Guard. I'm glad there is such a magazine in publication and there are thousands of students and beginners as well as old-timers who will agree.

I only hope *Radio-Craft* continues its policy of equally dividing its magazine between the serviceman and the experimenter. In my estimation some of the old-timers could learn a lot if they really investigated some of the circuits they pretend to scorn.

CHARLES M. WHITE, S/2c,  
Ft. Worth, Texas.

I heartily disagree with the letter of Mr. Esluk in the November issue. I think you will find that a large number of your readers are just hams like myself, with just a little smattering of technical radio knowledge. Therefore we find your easily understood articles very useful; particularly those concerning the locating of defects in radios and phonographs, which is more important now than ever before. In fact, I would be interested in reading articles

## TAKES MR. ESLUK'S SIDE

Dear Editor:

I have been reading *Radio-Craft* for several years and I agree with Mr. W. G. Esluk, whose letter appeared in the November issue.

Why don't you beginners get a handbook or some of the other good books now on the market for beginners?

Why has *Radio-Craft* decided to help the beginner so quickly? You have been publishing circuits that are so simple a five-year-old could understand them. When I was beginning I had to get out and dig.

Give us more articles on FM, television and U.H.F., also on the organization of W.E.R.S.

EDWIN BOHR (Age 15),  
Chattanooga, Tenn.

(This question is not, in our opinion, one of great importance. Even Mr. Esluk would not insist that beginners should be denied any assistance, and his strongest critic is not oblivious to the necessity of articles of a semi-advanced nature for the experienced radioman.—Editor)

on finding radio defects by simple methods not involving the use of meters and other expensive and easily damaged equipment. Information on electronic devices connected with the motion picture field would be very helpful to me.

The only way that the amateur can discover these little kinks which mean so much when struggling with a stubborn radio, is through a publication such as this.

CHARLES L. STACEY,  
New Bedford, Mass.

On page 125 (November issue) I noted the article, or rather letter, by Mr. W. G. Esluk and also your answer, and I agree with you that your magazine should continue to cover a varied field of radio, written in such manner as to be interesting to the engineer and understandable to the beginner.

As an example, I believe the article, "Radio Lines," on page 87, is the best article on this subject that I have ever read and it is explained in such way that any beginner should have no difficulty in understanding it.

GUY S. CORNISH,  
Cincinnati, Ohio.

In the Signal Corps today there are thousands of young fellows who in civilian life knew only enough about the radio to turn it off and on. Now they repair and install military equipment. They are beginners! You were one yesterday, Mr. Esluk! Why not then give the beginner a chance today?

H. P. DAVIDSON,  
Robbins Field, Fla.

I certainly agree with our Editor in regard to Mr. Esluk's letter. A lot of beginners are being educated in radio through the articles in *Radio-Craft*.

VIVIAN D. KENARD,  
Big Spring, Texas.

## APPRECIATES "RADIO WAVES"

Dear Editor:

This is my first letter to your splendid magazine and it is a letter of appreciation.

I possess \$30 worth of radio textbooks and literature and have studied them all. I was well pleased with them until I read "Radio Waves and Radio Antennas" by Eugene P. Bertin. This isn't the only article I have enjoyed immensely, but it is one which I remembered clearly afterwards. This was due, I think, to the author's unique way of putting it over. As far as I am concerned the September issue was worth the price of a year's subscription. So give Mr. Bertin more space and let him go ahead.

JACK P. GOLDEN,  
Olean, New York.

## A FEW ANONYMOUS ERRORS

Dear Editor:

"No Name, Brooklyn" probably left his identity a secret because his diagram ("Power-level Indicator for Recording," on Page 554 of the June issue), is a trifle in error.

The following mistakes appear:

1—Short circuit of power supply to ground through primary of output transformer.

2—"Free" grid on 6E5, no path for grid electrons to return to cathode.

3—No plate voltage on 6E5 as plate is connected to center tap of output transformer and cathode to one side—practically same D.C. potential.

4—Even though C2 were between the output transformer and ground, only one of the push-pull tubes would be useable because the plate of the other would be bypassed to ground through C2.

ROLAND J. MCMAHAN,  
Seattle, Wash.



"I guess the Sarge has a sore throat today!"

# Radio School Directory

TO OUR READERS—NOW IS THE TIME TO TAKE UP RADIO!

NOW, more than ever before America needs trained radio men. The Army, the Navy and the Air Force are continuously on the lookout for men who have had training in radio. Scores of war industries require radio men in various capacities throughout the country. There now is and there will be a great shortage of radio men for years to come. Reputable schools of Radio advertise to help you.

## RADIO TECHNOLOGY



RCA Institute offers an intensive two-year course of high standard embracing all phases of Radio and Television. Practical training with modern equipment. Also shorter specialized courses in Commercial Radio Operating, Radio and Television Servicing, and Aviation Communications. For Free Catalog write Dept. 44.

**RCA INSTITUTES, Inc.**

A Radio Corporation of America Service  
75 VARICK STREET NEW YORK 13, N. Y.



Correspondence Courses in  
**RADIO and ELECTRICAL ENGINEERING**

**ELECTRICAL ENGINEERING** Get good grasp of wide electrical field. Prepare yourself, at Low Cost, for secure future. Modern, simplified, you can understand quickly.  
**RADIO ENGINEERING** Extra fine course in radio, public address, photo-electric work.  
Trains you to be super-service man, real vacuum tube technician. Servicemen needed badly. Diploma on completion. Tuition \$25, either course. Deferred payment plan.  
**FREE** Get copies of school catalogs, student magazines, complete details. **SEND NOW!**

LINCOLN ENGINEERING SCHOOL Franklin Stn., Box 61-C59  
WASHINGTON, D. C. (Formerly at Lincoln, Nebr.)

### Pre-Induction

for Civilians and those entering Military Services. New classes now starting for men and women.

RADIO OPERATING CODE  
RADIO SERVICING — ELECTRONICS

New York Y.M.C.A. Schools  
4 W. 64th Street New York City

## COMMERCIAL RADIO INSTITUTE

A radio training center for  
twenty-three years.

RESIDENT COURSES ONLY

Pre-Induction, Broadcast, Service, Aeronautical and Radio telegraphy classes now forming for February 7. Literature upon request.

Dept. C., 38 West Biddle St., Baltimore 1, Md.

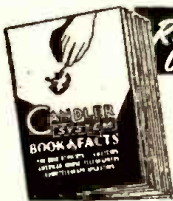

**RADIO OPERATORS WANTED**

Be a "key" man. Learn how to send and receive messages in code by telegraph and radio. Army, Navy and Commerce needs thousands of men. Good pay, adventure, interesting work. Learn at home quickly through famous Candler System. Write for **FREE BOOK**.  
**CANDLER SYSTEM CO.**  
Dept. 3-A, Box 928  
Denver, 1, Colo., U. S. A.

**RADIO OPERATION**  
**SERVICING**  
COMPLETE HOME TRAINING

Fit yourself for important work in wartime, and after. Make use of your spare time to master basic principles of radio. Up-to-date course includes electives in operating and servicing. Write for **FREE BULLETIN**. No obligation.  
**AMERICAN SCHOOL**  
Dept. R109, Drexel at 58th St., Chicago 37, Ill.

### AAF RADIO STUDENT MAKES PERFECT SCORE

Highest marks ever made by any student in the Army Air Forces radio schools was scored last month by Pvt. Serge Kirpatovsky, according to reports from Army authorities at Truax Field, where Pvt. Kirpatovsky took the Air Forces radio examinations.

An electrical engineer by trade Pvt. Kir-

## • TODAY

is the time to turn your  
**RADIO JOB into a**  
**SECURE POSITION!**

Do You Want a **BETTER JOB?**—A Secure Future? **NOW** is the time to prepare yourself for a lasting, profitable Career in Radio-Electronics!

Don't fool yourself! The good jobs—the permanent positions in radio don't come easy. The jobs that come easy are not easy to hold. The sure way to success is to build your future on a sound foundation of knowledge and ability . . . and the ability that you develop now is your assurance of a steady, sure income and a permanent job that will outlast the temporary employment conditions that exist today. Dividends for increased ability have never been so certain, as the radio-electronics industries look to the future.

CREI technical training is designed to do just one thing—to increase your ability, enabling you to hold the more responsible positions which lead to higher salaries. Hundreds of CREI students have accomplished this through the help of CREI training—just as many more hundreds will do in the future!

### • WRITE FOR FREE 32-PAGE BOOKLET

If you have had professional or amateur radio experience and want to make more money—let us prove to you we have something you need to qualify for a better radio job. To help us intelligently answer your inquiry—PLEASE STATE BRIEFLY YOUR BACKGROUND OF EXPERIENCE, EDUCATION AND PRESENT POSITION.



## CAPITOL RADIO ENGINEERING INSTITUTE

Home Study Courses in Practical Radio-Electronics Engineering  
for Professional Self-Improvement

Dept. RC-1, 3224-16th St., N. W.  
WASHINGTON 10, D. C.

Contractors to the U. S. Navy—U. S. Coast Guard—Canadian Broadcasting Corp.—Producers of Well-Trained Technical Radlomen for Industry.

## BOOK REVIEW

**GRAPHICAL CONSTRUCTIONS FOR VACUUM TUBE CIRCUITS**, by Albert Preisman. Published by McGraw-Hill Book Company. Stiff cloth covers, 5½ x 8½ inches, 237 pages. Price \$2.75.

Electron tubes belong in that class of circuits known to mathematicians as non-linear, which are not usually solvable by general mathematical methods. A common example is the resistance of a circuit containing a vacuum tube, together with fixed resistors. The resistance of the tube changes as the amount of current flowing through it varies, also according to voltage changes on either the grid or the plate. A change in any one of these factors may react and vary several others.

Under such circumstances, the advantages of graphical methods are immediately obvious. Starting from performance charts experimentally determined, and not being concerned with the inner meaning of the curves operated upon, solutions can be reached with an ease and directness not possible in the analytical method, even in those cases which can be handled analytically.

It is urged against the graphical method that it is not a method, properly speaking; it produces results for the given set of conditions but cannot give general information which may be applied to all sets of conditions in a general case. Even with this limitation—and others tabulated by the author—the graphical method is found to have a wide useful field.

The general considerations applying to electron tubes and to elementary graphical construction are developed, then the application of graphical methods to special circuits, including reactive loads, balanced amplifiers (a 66-page chapter on this subject), detection and miscellaneous constructions.

The "slipstick engineer" who finds himself forced to solve actual problems similar to those given in this work, without having the mathematical background usually considered necessary, will find much of interest here. Given the time to assign numerical values to the factors in the given figures and work out a problem or two, the methods can readily be mastered.

### EMERGENCY PICKUP

A correction in the description of this pickup, which appeared on Page 126 of the November issue, is in order. Mr. Leap informs us that in editing his item, the statement: "The real contact is between the bit of solder at the center and the diaphragm beneath it," was inserted.

He says, "There is absolutely no contact between the two diaphragms. A rubber ring or washer both inside and outside the outer diaphragm provides a small air space between the two diaphragms. It is the percussion or concussion of the outer element that impresses the sound on the inner one. I doubt that if the two diaphragms were connected the pickup would work as well. It might jam."

In connection with recent observances of the twentieth anniversary of the death of Charles Steinmetz, America's greatest electrical engineer, it was recalled that his greatest feat, "harnessing the lightning," consisted of producing discharges of more than 1,000,000 volts. General Electric, building on his discoveries, has just announced a new X-ray which operates on a potential of 100,000,000 volts.

**MOST  
OFTEN  
NEEDED**

# RADIO DIAGRAMS



## 1942 4 out of 5 Diagrams You Will Ever Need

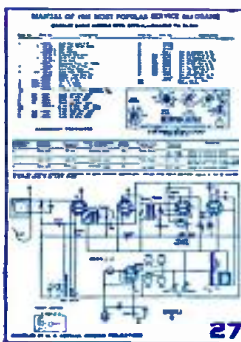

Find radio faults quickly. Make the needed repairs in any radio. Save time on every job. This large, new and inexpensive diagram manual has the circuit for every popular 1942 radio set. 4 out of 5 diagrams you will ever need are included.

### ALIGNMENT DATA INCLUDED

Clearly printed circuits, alignment data, parts lists, service hints are the facts you need to speed up War-time servicing. Repair radios quickly and properly—follow the factory instructions given in these manuals. 3.51 models of 40 largest manufacturers. 208 fact packed pages. Large size, 8½ x 11 in. Manual style binding. Price, postpaid **\$2.00**

## NEW, POPULAR, LOW-PRICED MANUALS

### 1941

These easy-to-apply, inexpensive manuals will help you repair radios faster. This volume covers 1941 models, with alignment data, I.F. peaks, and replacement parts lists. Compiled by M. N. Beitman, radio serviceman for many years, author, and teacher. Be an expert in radio servicing; simplify your work. 192 pages, 8½ x 11 inches. Only **\$2.00**

### 1940

Let this important manual give you over 80% of all 1940 circuits you will ever need, acquaint you with new developments, train you to service quickly and efficiently millions of sets. Data on F.M., portables, recording, etc. 417 models of 43 manufacturers. 208 pages. Net price **\$2.00**



### 1939

Another handy manual of the most popular diagrams you need. Circuit data, hints and information are time-savers and money makers for you. Let these diagram manuals guide you to easier service work. Why try to get along without helpful diagrams? Use this volume with 192 pages of diagrams of 39 makes. Only **\$2.00**

**Most Popular Models Made by:**  
Philco, RCA, Zenith, Sears, GE, Emerson, Belmont, Detrola Radio, Fada, United Motors, Westinghouse, Arvin, Majestic, Stewart-Warner, Admiral, Delco, Stromberg-Carlson, Western Auto, Sparton, Motorola, Wards, Gamble, and many others.

## Other Practical Radio Manuals

### How to MODERNIZE Radios for Profit



Cash-in by improving audio circuits, modernizing cabinets, adding features usually found only on late model sets. Practical job-sheets with schematics and photographs make the work easy. You are told how to obtain modernization work, what to charge, and how to complete the job quickly and efficiently. The complete, large size, 8½ x 11 in. manual is priced at only **\$1.00**

### PRACTICAL RADIO for War Training

This new, 1943 manual will clarify the important radio facts, explain the principles which may have puzzled you, and point the way to faster radio repairing. You will find hundreds of practical hints for mounting parts, testing components, trouble-shooting, using instruments. Needed useful theory in each chapter is followed with practical applications. This is the book that will help you repair radios faster, or obtain a good radio War-job, or get ahead in the Armed Forces. Use this timely book as your ready reference for finding the right answer to every radio problem. Written by M. N. Beitman, 336 large pages, 6x9 inches. Printed on thick, enamel paper. Almost 300 illustrations and diagrams to help you. Seal leatherette cover. Attractive manual-binding. Price only **\$2.95**

### PRACTICAL RADIO MATHEMATICS

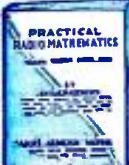

Introduces and explains the use of arithmetic and elementary algebra in connection with units, color code, meter scales, Ohm's Law, alternating currents, ohmmeter testing, wattage rating, series and parallel connections, capacity, inductance, mixed circuits, vacuum tubes, curves, the decibel, etc., etc., and has numerous examples. Net **25c**

See Your Radio Jobber or Send Coupon

### 1926-1938

The most popular volume of the series. Will pay for itself with the time saved during the first day of use. Includes all the popular old timers. Save hours on every job. 427 diagrams of the most-serviced radios of this period, with parts lists and alignment information. 244 pages, 8½ x 11 inches. Sold with a money back guarantee. Price, postpaid **\$2.50**



Compiled by M. N. Beitman, radio engineer, teacher, author, & serviceman.

## SAVE HOURS ON EVERY JOB

Be ready to make repairs in minutes instead of hours. You will be called upon to fix hundreds of models listed in these easy-to-use manuals. Tackle each job with the needed help found on every page in these handy service manuals. Greatest bargain in diagram books. Send your order today. Use these manuals this week.

## NO RISK TRIAL ORDER COUPON

SUPREME PUBLICATIONS, 328 S. Jefferson St., Chicago 6, ILL.

Ship the following manuals: (Money back guaranteed).

- 1942     1941     1940     1939     1926-1938  
 Also send other Supreme Publications as listed on attached paper.  
 I am enclosing \$....., send postpaid.     Send C.O.D.

Name: .....

Address: .....

(Use Coupon or Send Order in a Letter)

# Supreme Publications

PUBLISHERS OF RADIO BOOKS, MANUALS, AND DIAGRAMS

328 South Jefferson Street

Chicago, Illinois

# Audels RADIOMANS GUIDE

**1001 RADIO FACTS AND FIGURES**

**772 PAGES · 400 DIAGRAMS, CHARTS AND PHOTOS**

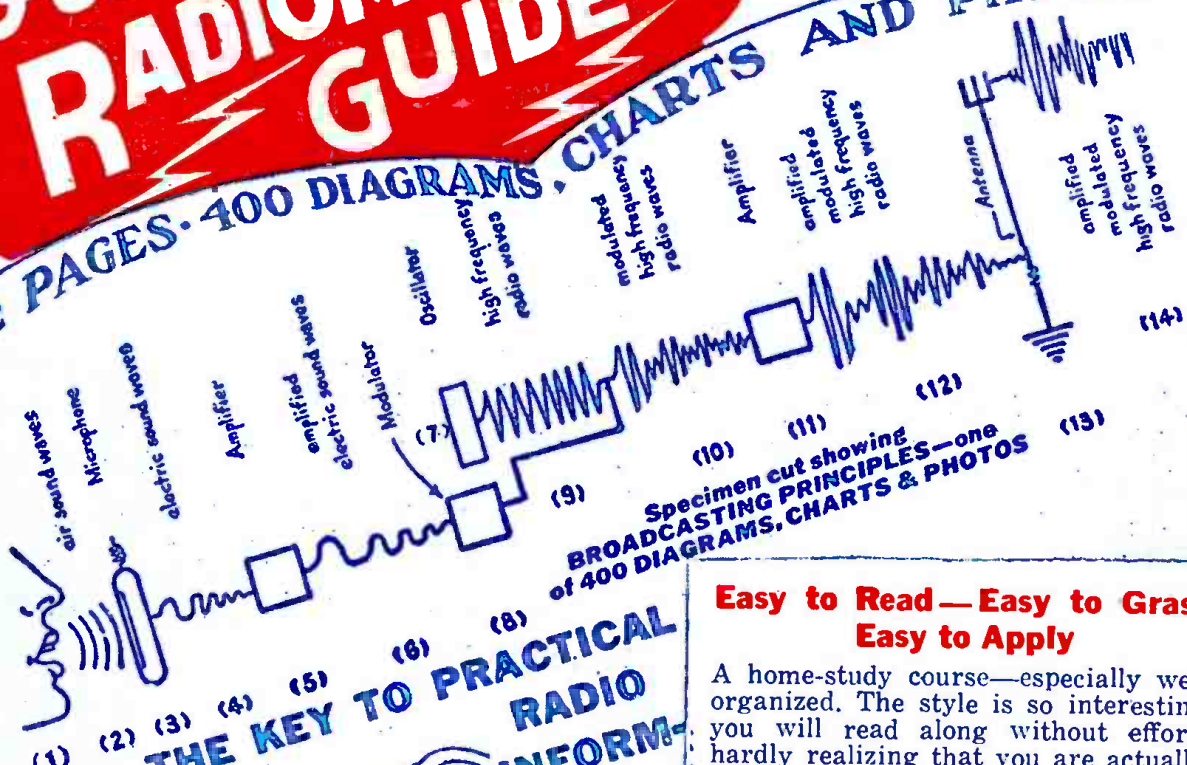

Specimen cut showing BROADCASTING PRINCIPLES—one of 400 DIAGRAMS, CHARTS & PHOTOS

**THE KEY TO PRACTICAL RADIO INFORMATION**

It gives you in useable form pointers on radio, including frequency modulation, television, etc. Also valuable inside information for Aviators, Marines, Commercial Operators and Technicians, Servicemen and Students.



**Q AND A  
UNIQUE  
QUESTION  
and  
ANSWER  
METHOD**

**Easy to Read—Easy to Grasp  
Easy to Apply**

A home-study course—especially well organized. The style is so interesting you will read along without effort, hardly realizing that you are actually studying and taking in vital information. Audels Radiomans Guide gives you just the right amount of mathematics required to cope with radio problems successfully. You can solve, with the aid of this extraordinary book, practically every radioproblem that comes up. At your finger tips is a complete index for instant use.



**Highly Endorsed**

**A COMPLETE LIBRARY IN ONE BOOK**

AUDELS RADIOMANS GUIDE gives authentic Principles and Practices in Construction, Operation, Service and Repairs. Covers clearly and concisely radio fundamentals—Ohm's Law—Physics of sound as related to radio science—Measuring instruments—Power supply—Resistors—Inductors—Condensers—Transformers and examples—Broadcasting stations—Radio Telephony—Receivers—Diagrams—Construction—Control Systems—Loudspeakers—Antennas—AutoRadio—Phonograph Pick-ups—Public Address Systems—Aircraft and Marine Radio—Radio Compass—Beacons—Automatic Radio Alarms—Short Wave—Coil Calculations—Testing—Cathode Ray Oscillographs—Static Eliminations—Trouble Pointers—Underwriter's standards—Units and tables. REVIEW QUESTIONS—READY Reference Index.

**7 DAYS' FREE TRIAL**

**\$4 COMPLETE PAY \$1 ONLY**

THEO. AUDEL & CO., Publishers  
49 West 23rd Street, 10, New York

Mail AUDELS NEW RADIOMANS GUIDE for free examination. If O.K. I will send you \$1 in 7 days; then remit \$1 monthly until \$4 is paid. Otherwise I will return it.

Name \_\_\_\_\_  
Address \_\_\_\_\_  
Occupation \_\_\_\_\_  
Reference \_\_\_\_\_

**MAIL THIS COUPON TODAY**